

Air Force Institute of Technology

AFIT Scholar

---

Theses and Dissertations

Student Graduate Works

---

3-11-2009

## Cooperative Unmanned Aerial Surveillance Control System Architecture

Theodore T. Diamond

Adam L. Rutherford

Jonathan B. Taylor

Follow this and additional works at: <https://scholar.afit.edu/etd>



Part of the [Systems Architecture Commons](#), and the [Systems Engineering and Multidisciplinary Design Optimization Commons](#)

---

### Recommended Citation

Diamond, Theodore T.; Rutherford, Adam L.; and Taylor, Jonathan B., "Cooperative Unmanned Aerial Surveillance Control System Architecture" (2009). *Theses and Dissertations*. 2517.  
<https://scholar.afit.edu/etd/2517>

This Thesis is brought to you for free and open access by the Student Graduate Works at AFIT Scholar. It has been accepted for inclusion in Theses and Dissertations by an authorized administrator of AFIT Scholar. For more information, please contact [richard.mansfield@afit.edu](mailto:richard.mansfield@afit.edu).



**COOPERATIVE UNMANNED AERIAL SURVEILLANCE CONTROL SYSTEM**

**ARCHITECTURE**

THESIS

Theodore T. Diamond  
LCDR, USN

Adam L. Rutherford  
Major, USAF

Jonathan B. Taylor  
Major, USAF

AFIT/GSE/ENV/09-M07

**DEPARTMENT OF THE AIR FORCE  
AIR UNIVERSITY**

***AIR FORCE INSTITUTE OF TECHNOLOGY***

**Wright-Patterson Air Force Base, Ohio**

APPROVED FOR PUBLIC RELEASE; DISTRIBUTION UNLIMITED

The views expressed in this thesis are those of the authors and do not reflect the official policy or position of the United States Air Force, Department of Defense, or the United States Government.

AFIT/GSE/ENV/09-M07

COOPERATIVE UNMANNED AERIAL SURVEILLANCE CONTROL SYSTEM  
ARCHITECTURE

THESIS

Presented to the Faculty

Department of Systems Engineering

Graduate School of Engineering and Management

Air Force Institute of Technology

Air University

Air Education and Training Command

In Partial Fulfillment of the Requirements for the  
Degree of Master of Science in Systems Engineering

Theodore T. Diamond, BS  
LCDR, USN

Adam L. Rutherford, BS, MBA  
Major, USAF

Jonathan B. Taylor, MS  
Major, USAF

March 2009

APPROVED FOR PUBLIC RELEASE; DISTRIBUTION UNLIMITED.

AFIT/GSE/ENV/09-M07

COOPERATIVE UNMANNED AERIAL SURVEILLANCE CONTROL SYSTEM  
ARCHITECTURE

Theodore T. Diamond, BS  
LCDR, USN

Adam L. Rutherford, BS, MBA  
Major, USAF

Jonathan B. Taylor, MS  
Major, USAF

Approved:

//signed//

\_\_\_\_\_  
Dr. David Jacques (Chairman)

\_\_\_\_\_  
(11 Mar 2009)

//signed//

\_\_\_\_\_  
Dr. Richard Cobb (Member)

\_\_\_\_\_  
(11 Mar 2009)

//signed//

\_\_\_\_\_  
LtCol Frederick Harmon (Member)

\_\_\_\_\_  
(11 Mar 2009)

## **Abstract**

Intelligence, surveillance and reconnaissance (ISR) is a high-demand Department of Defense mission performed by unmanned aircraft systems (UASs) at the tactical and theater levels. Coordinating UASs through cooperative control offers the advantages of persistence, distributed and adaptable sensor coverage, and reduced revisit time on points of interest. The purpose of this thesis is to apply systems engineering principles to the problem of developing a flexible, common control system for cooperative UAS surveillance at the tactical level. The AFIT team developed a concept of operations (CONOPS) encompassing various users and surveillance tasks. The team then used the scenarios in the CONOPS to build a conceptual architecture. Concurrently, the team constructed a developmental test system that closely resembled the architecture and successfully conducted flight tests of multiple aircraft. The team then used this architecture and the prototype system to identify significant technical risks and future research areas to be explored prior to the development of an operational system.

## Acknowledgments

We would like to thank a number of people, without whom our work would not be possible. First, we sincerely thank our thesis advisor, Dr. Jacques, for his guidance, patience, and invaluable System Architect support. We'd also like to thank the other students who shared their ideas, contributed to our research, and helped with flight testing: Capt Farrell, Capt Booth, Austin Smith, Capt Rosal, Capt Lenfestey, and Capt Cring. Additionally, we'd like to thank Dr. Cobb and LtCol Harmon for helping to keep this group pointed in the same direction. We extend a special thanks to Don Smith and John McNees for their outstanding test support, and to LtCol Shearer for his test and safety supervision. Thanks also to 2Lt Yates for his expertise with Procerus systems and C++ coding. Finally, we'd like to thank the staff at Camp Atterbury for all their help in providing us with a place to flight test.

## Table of Contents

	Page
Abstract.....	iv
Acknowledgments.....	v
Table of Contents.....	vi
List of Figures.....	x
List of Tables.....	xiii
I. Introduction.....	1
Thesis Introduction.....	1
Problem Statement.....	2
Scope and Assumptions.....	3
Thesis Purpose.....	4
Thesis Outline.....	5
II. Background.....	6
Intelligence, Surveillance, and Reconnaissance.....	6
Unmanned Aircraft Systems.....	7
Overview and History.....	7
Categories.....	9
Growing Requirements.....	10
Cooperative Control.....	11
Definition.....	11
Persistent Surveillance.....	12
Increased Sensor Coverage.....	12
Adaptable Sensor Coverage.....	13
Reduced Revisit Time.....	13
Recent Research.....	14
Scholarly Research.....	14
AFRL.....	14
AFIT Theses.....	15
Concurrent Research.....	17
III. Methodology.....	19
Systems Engineering.....	19
Systems Engineering Process.....	19
DoDAF.....	20
JCIDS Assumptions.....	21
Concept of Operations.....	22
Conceptual Architecture.....	23



	Page
System Context .....	23
DoDAF Product Choices .....	24
Production of Architecture Views .....	26
Test Architecture.....	29
Airframe.....	29
Autopilot.....	30
Communications.....	31
Sensors.....	32
Ground Control Hardware and Software.....	33
Video Capture Hardware.....	34
Control Algorithm Interface.....	37
Hardware and Software-in-the-Loop Simulation.....	38
Flight Testing.....	40
Technological Risks.....	48
IV. Results.....	49
Concept of Operations .....	49
Conceptual Architecture .....	50
AV-1.....	50
AV-2.....	51
OV-1.....	51
OV-5.....	54
OV-2.....	64
SV-1.....	65
SV-4.....	68
SV-5.....	69
Test Architecture.....	71
OV-1.....	71
OV-2.....	73
OV-5.....	73
SV-1.....	75
Flight Testing.....	78
Autopilot Tuning.....	78
BATCAM Performance.....	80
Communications Performance.....	98
Human Factors Observations.....	103
Risk Areas.....	107
UAS Performance.....	108
Endurance.....	108
Communications.....	110
Distributed vs. Centralized Processing.....	112
Video Capture Limitations.....	113
Human Factors Issues.....	113
Interfaces.....	114

	Page
Integration into the National Airspace System .....	115
V. Summary and Recommendations.....	116
Summary .....	116
Remarks .....	117
Recommendations.....	117
Seek UAV Operations at WPAFB.....	117
Reexamine Airframe Selection.....	118
Create a Robust/Common Development Interface.....	118
Utilize the Latest Hardware and Software.....	119
Investigate On-Board Processing Power and Implementation.....	119
Future Areas of Study .....	120
Channel and Bandwidth Deconfliction.....	120
Distributed vs. Centralized Control.....	120
Communication Relay Capability.....	121
Minimum Parameter Set.....	121
Operator Trust and Workload.....	121
Appendix A: List of Acronyms.....	122
Appendix B: CUSS Concept of Operations.....	125
Purpose.....	125
Time Horizon, Assumptions and Risks .....	125
Time Horizon.....	125
Assumptions.....	126
Risks.....	127
Military Challenges.....	129
Mission Statement.....	129
Concerns.....	130
Synopsis.....	131
Desired Effects.....	132
“TiVo” Capability.....	132
Persistent Surveillance.....	132
Enhanced Sensor Coverage.....	133
Reduced Revisit Time.....	133
Adaptable Sensor Coverage.....	133
Necessary Capabilities.....	133
Communications Hardware.....	133
End User Equipment.....	134
Control Algorithms.....	134
Enabling Capabilities.....	134
Responsive Launch and Recovery.....	134
Precision Geolocation.....	134
Communication Enablers.....	135

	Page
Beacon Following Capability .....	135
Host Computer .....	135
UAV Platform and Sensors .....	135
Sequenced Actions .....	136
General System Functions .....	136
Employment Scenarios .....	140
Command Authorities and Relationships .....	144
Summary .....	145
Appendix C: AV-1 Overview and Summary Information .....	146
Identification .....	146
Background .....	146
Purpose .....	147
Scope .....	147
Time Frame .....	147
Appendix D: AV-2 Integrated Dictionary .....	148
Introduction .....	148
Integrated Dictionary Overview .....	148
Integrated Dictionary Purpose .....	148
Integrated Dictionary Description .....	148
Integrated Dictionary Content .....	149
Appendix E: CUSS OV-1 Operational Concept .....	176
Appendix F: CUSS OV-2 Operational Node Connectivity Description .....	177
Appendix G: CUSS OV-5 Operational Activity Model .....	178
Appendix H: CUSS SV-1 System Interface Description .....	185
Appendix I: CUSS SV-4 System Functionality Description .....	186
Appendix J: CUSS SV-5 Activity to Function Traceability Matrix .....	187
Appendix K: Test OV-1 System Concept .....	188
Appendix L: Test OV-2 Operational Node Connectivity Description .....	189
Appendix M: Test OV-5 Operational Activity Model .....	190
Appendix N: Test SV-1 System Interface Description .....	197
Appendix O: Test to Conceptual Component Mapping Matrix .....	198
Bibliography .....	199

## List of Figures

Figure	Page
Figure 1. UAV Photographs .....	8
Figure 2. Systems Engineering Process .....	20
Figure 3. External vs. Context Systems .....	24
Figure 4. Prescribed DoDAF Process Flow .....	25
Figure 5. Architecture Product Sequence Used .....	26
Figure 6. SIG Rascal .....	29
Figure 7. BATCAM MAV .....	30
Figure 8. Procerus Technologies Kestrel™ Autopilot .....	31
Figure 9. BATCAM CCD Cameras and Camera Pod .....	32
Figure 10. Virtual Cockpit™ User Interface .....	33
Figure 11. Procerus Technologies Commbox .....	34
Figure 12. Video Capture Equipment Setup .....	35
Figure 13. Quad Video Display .....	36
Figure 14. Software-in-the-Loop Setup .....	39
Figure 15. Hardware-in-the-Loop Setup .....	40
Figure 16. Camp Atterbury Joint Maneuver Training Center .....	41
Figure 17. Flight Test Hardware Schematic .....	43
Figure 18. Laptop and Monitor .....	44
Figure 19. Quad Switcher, DVR, Wall Monitor, and Commbox .....	44
Figure 20. Video Receivers and Dual Diversity Controllers .....	45
Figure 21. Trailer Mast and Antennas .....	46
Figure 22. CUSS OV-1 Operational Concept .....	52
Figure 23. CUSS A-0 External Systems Diagram .....	55
Figure 24. OV-5 A0 Provide Surveillance .....	57
Figure 25. CUSS OV-5 A1 Plan Mission .....	58
Figure 26. CUSS OV-5 A2 Manage UAVs .....	59

Figure	Page
Figure 27. CUSS OV-5 A3 Control Sensors .....	61
Figure 28. CUSS OV-5 A4 Manage Surveillance Data.....	62
Figure 29. CUSS OV-2 Operational Node Connectivity Description .....	65
Figure 30. CUSS SV-1 System Interface Description .....	66
Figure 31. CUSS SV-4 System Functionality Description.....	68
Figure 32. Test OV-1 System Concept.....	72
Figure 33. Test OV-5 A-0 External Systems Diagram.....	74
Figure 34. Test SV-1 System Interface Description .....	76
Figure 35. Persistent Surveillance and Turn Test Timeline.....	82
Figure 36. Example Altitude Profile.....	83
Figure 37. 4-Ship Altitude Profile .....	84
Figure 38. Altitude Deviations.....	84
Figure 39. Altitude Deviation Histogram .....	86
Figure 40. Altitude Deviation Cumulative Distribution Function.....	87
Figure 41. Example Navigation Ground Track and Waypoints .....	88
Figure 42. Course Deviation Definition.....	89
Figure 43. Course Deviations .....	89
Figure 44. Course Deviation Histogram .....	91
Figure 45. Course Deviation Cumulative Distribution Function.....	91
Figure 46. Example Orbit Ground Track and Waypoints.....	92
Figure 47. Orbit Deviation Definition .....	93
Figure 48. Orbit Deviations .....	94
Figure 49. Orbit Deviation Histogram.....	95
Figure 50. Orbit Deviation Cumulative Distribution Function.....	96
Figure 51. Virtual Cockpit™ Agent List .....	104
Figure 52. Virtual Cockpit™ Map Screen.....	105
Figure 53. Four Ship Persistent Surveillance Scenario – Small Battery.....	109
Figure 54. Four Ship Persistent Surveillance Scenario – Large Battery.....	110
Figure 55. CUSS OV-1 Operational Concept.....	176

Figure	Page
Figure 56. CUSS OV-2 Operational Node Connectivity Description .....	177
Figure 57. CUSS OV-5 A-0 External Systems Diagram .....	178
Figure 58. CUSS OV-5 A0 Context Diagram .....	179
Figure 59. CUSS OV-5 A0 Provide Surveillance.....	180
Figure 60. CUSS OV-5 A1 Plan Mission .....	181
Figure 61. CUSS OV-5 A2 Manage UAVs.....	182
Figure 62. CUSS OV-5 A3 Control Sensors .....	183
Figure 63. CUSS OV-5 A4 Manage Surveillance Data.....	184
Figure 64. CUSS SV-1 System Interface Description .....	185
Figure 65. CUSS OV-4 System Functionality Description .....	186
Figure 66. Test OV-1 System Concept.....	188
Figure 67. Test OV-2 Operational Node Connectivity Description .....	189
Figure 68. Test OV-5 A-0 External Systems Diagram .....	190
Figure 69. Test OV-5 A0 Context Diagram.....	191
Figure 70. Test OV-5 A0 Provide Surveillance.....	192
Figure 71. Test OV-5 A1 Plan Mission .....	193
Figure 72. Test OV-5 A2 Manage UAVs .....	194
Figure 73. Test OV-5 A3 Control Sensors.....	195
Figure 74. Test OV-5 A4 Manage Surveillance Data.....	196
Figure 75. Test SV-1 System Interface Description .....	197

## List of Tables

Table	Page
Table 1. CUSS SV-5 Activity to Function Traceability Matrix .....	70
Table 2. Test to Conceptual Component Mapping Matrix .....	77
Table 4. Course Deviation Statistics .....	90
Table 5. Orbit Deviation Statistics .....	94
Table 6. Polling and Non-Polling Telemetry Comparison .....	99
Table 7. CUSS AV-2 Integrated Dictionary .....	149
Table 8. CUSS SV-5 Activity to Function Traceability Matrix .....	187
Table 9. Test to Conceptual Component Mapping Matrix .....	198

# COOPERATIVE UNMANNED AERIAL SURVEILLANCE CONTROL SYSTEM ARCHITECTURE

## I. Introduction

### Thesis Introduction

Current experience in Iraq and Afghanistan has shown an ever-increasing need for the use of unmanned aircraft systems (UASs) to accomplish a variety of missions within a war-time environment. As combat theater requirements and experience with UASs grow from the widespread success of these platforms, the Department of Defense (DoD) is increasingly relying on UASs to reduce risks to humans and accomplish a multitude of missions that were previously conducted by manned systems. These missions include performing traditional intelligence, surveillance, and reconnaissance (ISR) activities, in addition to conducting search and rescue (SAR) and broad area search operations. To date, most unmanned aerial vehicles (UAVs) operate independently and physically separated from one another to accomplish a specific task or single mission objective. This limits the amount of terrain coverage and the mission flexibility for the end user. To provide additional and more responsive mission capabilities to the warfighter, UAVs must be able to work in cooperative formations and must be made more adaptable to a variety of mission tasks required by users in an operational theater. To implement cooperative UAV capabilities, an effective architecture that enables cooperative



command and control of existing and future UAS platforms and their sensors is necessary.

To explore the feasibility and effectiveness of real-world cooperative UAV operations, this team developed a conceptual system architecture for a cooperative UAS designed to conduct a variety of ISR missions. Simultaneously, the team constructed a developmental flight test system using “off-the-shelf” components. The team used the architecture and prototype system to investigate a number of risks and technology shortfalls in areas such as UAV and sensor control, data display, and communication bandwidth in the operational environment. This thesis work was conducted in conjunction with six other students, exploring specific aspects of cooperative control and ISR optimization: collision avoidance (COLA), efficient flight path planning, linear distributed coverage optimization, sensor aim point navigation, and trust in automation.

## **Problem Statement**

Current UASs must operate in a variety of conditions, including desert, urban, maritime, and temperate environments, and perform numerous diverse and challenging missions. UAS missions may require operations beyond line-of-sight of the tactical operator, the prosecution of time sensitive targets, long loiter times, and the ability to carry and utilize a variety of sensors.

While the DoD is the predominant federal government UAS user, numerous other governmental organizations, such as the Department of Homeland Security (DHS), the U.S. Coast Guard, and the Federal Emergency Management Agency (FEMA), are

investigating UASs in a variety of remote sensing missions such as law enforcement, damage assessment, and terrain mapping [1:3]. Each agency is moving quickly to expand or create its own UAV fleet with little or no regard to commonality and interoperability. Typically, each UAV functions as a single vehicle platform conducting a single mission. Each UAS also creates a logistical footprint, including numerous operators and support personnel, adding a significant human resource requirement wherever the UAS operates. As the type, complexity, and overall number of UAS missions increase, operators must have systems for mission planning, vehicle/sensor management and control, displaying and recording sensor data, and producing surveillance products that are exportable to the intelligence consumer. While UAS design is expected to provide increased capabilities to future warfighters, it must also address operator burden and logistical footprint size.

### **Scope and Assumptions**

The AFIT team sought to develop a high-level conceptual architecture for a system to cooperatively control multiple UAVs in a variety of surveillance missions. Additionally, the team aimed to construct and test a prototype system for researching cooperative control algorithms and to thoroughly document test plans and procedures for future groups. The team documented gaps between the “as built” test bed and the conceptual architecture through a test architecture. In addition, the team sought to identify risk areas and provide viable mitigation options for operational system development efforts. The team also provided systems engineering support in integrating

and testing algorithms developed by the other AFIT students conducting cooperative control studies.

Based on previous research, the team began with the assumption that a Joint Capabilities Integration and Development System (JCIDS) analysis had been performed, identifying the need for additional ISR capabilities and recommending cooperative UASs to fulfill those needs. The team focused on a common control system architecture designed to be flexible and expandable from single to multiple vehicles ranging in size from man-portable micro air vehicles (MAVs) to larger systems deployable from more traditional airfields.

Hardware and software resource constraints limited the components used in the test system and how closely it implemented the conceptual architecture. The team restricted the testing to a maximum of four UAVs of the same type. The team also limited the scope of the tests to validating the ability to simultaneously control multiple UAVs, gather telemetry and sensor data from multiple UAVs, and utilize student-developed control algorithms to perform various tasks associated with the mission area.

### **Thesis Purpose**

The purpose of this thesis is to develop an effective and expandable architecture for multi-UAV cooperative command and control. To support this effort, the team created a prototype system to validate the theoretical design, identify areas of technical risk, and support the development of cooperative control algorithms. The prototype system can serve as a test bed for future cooperative control research. The team also

identified areas where additional research is warranted to fully understand the requirements and limitations of cooperative control technologies.

## **Thesis Outline**

The remainder of this document explores several of the challenges, opportunities, results, and areas of future research that will be required to produce true cooperative control UAS capabilities for tomorrow's warfighters. Chapter II, *Background*, examines capability gaps in ISR, provides a brief history of UASs, presents an overview of cooperative UAV control, and examines past research efforts. Chapter III, *Methodology*, provides a brief synopsis of the systems engineering process, an account of how this effort was scoped, an explanation of architectural products, and a description of the test system development and flight testing. Chapter IV, *Results*, presents the conceptual cooperative control architecture and the developmental flight test system, and compares and contrasts differences between the two. It examines several of the challenges and limitations associated with cooperative control systems captured by in-flight testing and laboratory simulation. Additionally, it discusses risk issues identified during architecture development, lab testing, and flight testing. Lastly, Chapter V, *Conclusions and Recommendations*, summarizes the results and proposes areas of research for additional study to create effective cooperative UAS capabilities.

## II. Background

### Intelligence, Surveillance, and Reconnaissance

The collection of intelligence information plays a major role in DoD operations. It helps military personnel at all levels understand the situations they face and make better decisions. Joint doctrine describes the goal of this mission by stating, "This joint intelligence effort facilitates that degree of dominance in the information domain which permits the conduct of operations without effective opposition" [2:xi]. Its importance is evidenced by its inclusion at high levels of joint and service doctrine. The mission of collecting, analyzing, and disseminating battlespace information is often referred to as Intelligence, Surveillance, and Reconnaissance (ISR). The DoD terminology dictionary defines ISR as:

An activity that synchronizes and integrates the planning and operation of sensors, assets, and processing, exploitation, and dissemination systems in direct support of current and future operations. This is an integrated intelligence and operations function. [3:273]

Although ISR is often used to describe a single type of mission, the acronym's individual terms have different meanings. Reconnaissance refers to collecting specific information on an area or point of interest, generally for an instant or short period of time. Surveillance aims to maintain sustained observation of an area of interest over a specified period of time (generally longer than reconnaissance). Intelligence is the knowledge and information gained from operations like surveillance and reconnaissance [4:2].

This thesis most often uses the term "surveillance" when referencing the system explored in this research, because a persistent observation capability was the driving

factor in its design. It should be noted, however, that the capabilities of the system also encompass performing reconnaissance and producing intelligence. "Surveillance" is used for consistency, but the reader should understand this is inclusive of other ISR activities.

## **Unmanned Aircraft Systems**

### ***Overview and History.***

Intelligence collection is performed by humans as well as mechanical systems. Technological collection methods include an array of vehicles and sensors including ground listening stations, satellites, and manned and unmanned aircraft. Unmanned systems, particularly aerial ones, are playing a growing role in the ISR mission. UASs are composed of UAVs, the ground operators that control them, and the associated hardware that facilitates command, control, and communication between the operators and vehicles.

The UAS concept has been used for a surprisingly long time. During the U.S. Civil War, both sides launched balloons loaded with explosives at each other [5]. The technology to remotely pilot aircraft was developed after World War II, facilitating the predecessors of today's modern UASs. In the Vietnam conflict, the AQM-34 Firebee drone, shown in Figure 1, conducted a wide variety of missions including camera surveillance, leaflet dropping, and surface-to-air missile detection [5]. During the 1980s, extensive Israeli research led directly to U.S. systems like the Hunter and Pioneer UAVs, also shown in Figure 1. The latter was used in Operation Desert Storm to spot shelling locations for U.S. warships [5].

Recent advances have produced larger and longer endurance UASs, including the RQ-4 Global Hawk UAV which has a 116 foot wingspan [6] and can loiter for over 24 hours [5]. UAS communication technology has also advanced enough to enable the Predator and Global Hawk UAVs, shown in Figure 1, to be routinely controlled from ground stations on the opposite side of the world.



**Figure 1. UAV Photographs [7; 8; 9; 10; 11]**

The development of UASs has been spurred primarily by a desire to reduce the risk to human life by removing the operator from exposure to threats. This includes enemy fire, but also harsh environmental conditions such as the presence of radiation or chemical agents. Unmanned systems offer a number of other advantages as well. Because the operators can be swapped out without the aircraft landing, UAV mission lengths are not limited by human endurance factors. Also, without the need to

accommodate a pilot and the associated life-support systems, UAVs can be built smaller, lighter, and more agile than manned aircraft. This makes them generally harder to detect as they execute their assigned mission. The lack of onboard human support systems also lowers the overall cost of the UAV compared to a similar piloted aircraft. However, there are added costs and complexities associated with the ground control hardware and communications equipment of unmanned systems.

### ***Categories.***

Several methods of categorization have been used to describe UASs. The *Unmanned Systems Roadmap (2007-2032)* was created to provide a common vision for the development of unmanned systems. It separates UASs into three size categories: Small - less than 55 pounds; Tactical - 55 to 1320 pounds; and Theater - over 1320 pounds [12:20]. It also distinguishes a Combat category as a weapons-carrying strike platform weighing over 1320 pounds [12:20]. Other sources, like the Government Accountability Office (GAO), make a very similar delineation. The GAO classifies UASs into three categories based on size and mission: Man-Portable - small, self-contained, and controlled at the combat team level; Tactical - larger, supporting various levels of tactical command; and Theater - controlled by theater commanders and supporting theater-level requirements [13:8].

In an article in *Joint Force Quarterly*, Lieutenant General David Deptula suggests that referring to UASs by their level of war, i.e., "tactical," "operational," or "strategic," is flawed since any system can be employed at any level. He recommends classifying them in terms of their overall capabilities, e.g., aircraft performance, sensors, ground support, etc., and divides them into two categories: Local-Area and Theater-Level [14:49-50].



The system discussed in this thesis is designed to be operated by and provide surveillance for units deployed on the battlefield. Its capabilities can support foot soldiers, convoy commanders, or other tactical users, and are not dependent on the size of the UAV platform. While the team often refers to the system as "tactical," this term is most closely related to the "Local-Area" category described by LtGen Deptula, rather than being descriptive of any size or weight constraints.

### ***Growing Requirements.***

The use of UASs has grown dramatically over the last decade. In an article for *Joint Force Quarterly*, Colonel Jeffrey Kappenman notes that the number of UAV airframes in the DoD inventory increased from less than 50 in 2000 to over 3,900 in 2007 [13:2]. As of April 2008, Army UAVs alone had flown over 375,000 hours and almost 130,000 sorties in Iraq and Afghanistan [15:21]. As the experience and successes with UASs has continued to grow, the number and types of missions these systems are tasked to execute has expanded. Current operations in Iraq and Afghanistan routinely involve UAVs that carry and employ munitions. Additional missions being explored include search and rescue, broad area search, and logistical supply delivery. To support this growth, the 2006 Quadrennial Defense Review (QDR) specifically states plans to further increase the development and procurement of UASs [16:6,57].

The increased demand for UASs has been due, at least partially, to a capability gap in meeting ISR mission needs. The 2006 QDR cites the need for UASs to "increase persistent surveillance, nearly doubling today's capacity," and to "provide more flexible capabilities to identify and track moving targets in denied areas" [16:6,57]. In a survey of combatant command (COCOM) and military department unmanned vehicle needs,

"Reconnaissance" was listed as the number one priority over all three domains: land, sea, and air [12:21-23]. "Precision Target Location and Designation," a related ISR task, was listed as the number two priority for UASs [12:21]. According to Col Kappenman, "Army commanders at all tactical levels (division and below) have identified a requirement for organic UAS[s] to support their operations" [15:20].

As more UASs are assigned to performing ISR tasks, corresponding tactics, techniques, and procedures have been developed to employ them for surveying ground routes, base perimeters, large areas, and particular features of interest [17]. There are tactical convoy operations procedures for using UASs to scout roads and escort vehicles as they traverse Main Supply Routes (MSRs) in wartime theaters [18]. Although UASs are predominantly associated with military intelligence collection, their use is not limited to the DoD. U.S. Customs and Border Protection are flying Predator B aircraft to search for smugglers and illegal immigrants, while the U.S. Forest Service is also using them to locate and map forest fires [19].

## **Cooperative Control**

### ***Definition.***

Cooperative control is one of the newest concepts being explored for UASs. It refers to the coordinated direction of UAV platforms in order to create synergy in their operations. This coordinated control produces cooperative behavior among UAVs. It not only affects the UAVs' flight paths, but their sensor aim points and settings as well.

The 2007 *Unmanned Systems Roadmap* lists Cooperative Behavior as one of its technology development objectives [12:50]. It distinguishes collaboration between unmanned systems from collaboration between unmanned and human systems [12:50-51]. Although it addresses aspects of the latter, this research is primarily concerned with the former: unmanned platforms acting in concert with one another as a team or in a formation.

### ***Persistent Surveillance.***

Cooperative control offers several capability improvements in conducting ISR tasks. First, it allows a greater degree of persistence in surveillance. On-station aircraft can be replaced when they run low on fuel or encounter malfunctions. A continuous cycling of fresh UAVs provides the possibility of indefinite surveillance of an objective. In some cases, a single UAV cannot physically keep its sensor coverage on a target because of its flight path through the environment. For example, if the door on one side of a tall building is the objective, the single UAV's sensor may not be able to maintain visibility on the door because of masking by the airframe or building as the UAV turns. By cooperatively positioning two or more UAVs, sensor coverage of the door can be provided by one aircraft when it is obscured from another.

### ***Increased Sensor Coverage.***

Using a greater number of UAVs and sensors in the air at the same time increases the effective sensor footprint of the entire system and allows individual sensor coverages to be dispersed over an area. Multiple UAVs can search a defined zone more quickly than a single vehicle by breaking up the task into smaller pieces for each to cover. The combined coverage may also be concentrated in one geographic location. For example,

multiple UAVs flying in a line-abreast formation can effectively provide a combined wide field-of-view out in front of them.

***Adaptable Sensor Coverage.***

Coordinating multiple UAVs allows the overall effect of their combined sensor coverage to be reconfigured. This change can be in response to the behavior of the surveillance subject. If the system is tracking a vehicle, all sensors may be centrally fixed on that target; however, if the vehicle enters a covered parking garage, the sensors may be distributed to cover all the exits from the garage. This reconfiguration can also support a change in the focus of the mission. For example, four UAVs may be surveying a large area when one locates a target of interest. The coverage can then be adapted so that one or two UAVs focus sensors on the target while the others continue the area surveillance.

***Reduced Revisit Time.***

When surveilling a large area, perimeter, or route, the time between sensor passes over any particular point (revisit time) is a key mission parameter. A longer revisit time increases the chance that a fleeting target or activity of interest will be missed by the surveillance system. By using multiple UAVs and coordinating their actions, the overall revisit time can be reduced, and the system can be optimized to meet a particular desired revisit time.

## **Recent Research**

A variety of research has begun to emerge relating to UAS architectures and cooperative control. The team surveyed a number of sources to establish a baseline for the present work.

### ***Scholarly Research.***

Many recent scholarly papers have addressed aspects of cooperative UAS control. Their topics range from task allocation optimization [20], to resource allocation [21], to path planning optimization [21], and collision avoidance [22]. Other efforts have developed functional hardware-in-the-loop ground test systems [23] and multi-UAV flight test systems [24; 25] to evaluate control schemes. These research groups documented aspects of their system architectures, such as communications and vehicle internal data flows [24:2]; however, none attempted to apply a comprehensive systems engineering approach to developing a cooperative control system and corresponding architecture.

### ***AFRL.***

The Air Force Research Laboratory (AFRL) at Wright Patterson Air Force Base (AFB), OH is dedicated to investigating new technologies to aid the warfighter. It is currently conducting studies on fielding cooperative UASs for a variety of ISR tasks, including route, perimeter, and urban surveillance. The team consulted with several members of AFRL throughout the course of the project to stay abreast of ongoing research efforts.

AFRL identified a number of areas for closer study to include:

- Communications constraints in pushing high bandwidth data (such as video streams) over long distances using size-constrained vehicles.
- Relay communications technologies to pass commands and data between UAVs in a formation.
- Optimization of UAV coverage across a linear path to minimize revisit time.
- Adaptation to UAV formation changes such as aircraft insertion, deletion, and reordering.
- Methods for dealing with system disturbances such as wind.
- Collision avoidance methods.

AFRL researcher Dr. Derek Kingston co-authored a paper that explored a decentralized approach to cooperative perimeter surveillance. His research group reduced the data passed to each UAV down to the perimeter length, and the number of vehicles on either side of each UAV. Additionally, each aircraft passed data to any aircraft it met in flight, effectively extending the communication range of the system. The algorithm accounted for a changing perimeter size as well as the insertion or deletion of UAVs from the team. His group demonstrated the ability to perform a coordinated distribution of UAVs with limited communications range and bandwidth [26].

#### ***AFIT Theses.***

The research in this paper directly follows from several previous AFIT projects. In 2004-2005, Captain Cory Cooper, Matthew Ewoldt, Steaven Meyer, and Edward Talley developed operational scenarios and a systems architecture for an unmanned MAV ISR system [27]. They directly identified Special Operations Command (SOCOM)

counter-terrorism and special reconnaissance ISR requirements, and traced how their envisioned system met identified needs [27].

Major Laird Abbot, Christian Stillings, Maj Craig Phillips, and Capt Garrett Knowlan conducted a systems engineering analysis in conjunction with an AFRL program to develop a UAS for finding, tracking, and engaging high-value fleeting targets in 2006-2007. They produced a mission area analysis, architecture products, and risk mitigation and test planning recommendations to support the acquisition of a functional system [28]. One of their primary conclusions was that a rigorous systems engineering process is beneficial and necessary when designing systems to meet warfighter requirements, even when those needs are urgent and a rapid acquisitions process is used [28:129, 131].

Lieutenant Commander Gregory Sakyrd and Capt Douglas Ericson continued these efforts in 2007-2008. They developed a working Fleeting Target Technology Demonstrator to serve as a test-bed for MAV research [29]. Their setup included a commercial off-the-shelf (COTS) autopilot and control software installed on a gas-powered remote controlled (RC) aircraft [29:28-32]. LCDR Sakyrd and Capt Ericson's main emphasis was developing a mission-focused software interface that operated in conjunction with the COTS control software. Their Fleeting Target Controller interface was designed to incorporate tools to predict an intercept path to a fleeting target and to allow the operator to guide the MAV on a terminal trajectory [29].

In conjunction with LCDR Sakyrd and Capt Ericson's research, Capt Nate Terning developed an algorithm to heuristically determine the optimal flight path to place a UAV sensor on a moving target [30]. His Pathmaker algorithm was incorporated into

LCDR Sakyrd and Capt Ericson's Fleeting Target Controller, allowing the operator to generate a flight plan from specified target parameters [30].

Ensign Troy Vantrease also worked with LCDR Sakyrd and Capt Ericson. He created and tested a Cursor-on-Target interface integrated with the Fleeting Target Controller [31]. It allowed an operator to provide terminal guidance to a MAV through mouse commands on the sensor video screen [31].

Concurrent with the Fleeting Target Controller work, Second Lieutenant John Hansen researched guidance of a relay MAV for passing sensor and command data between an ISR MAV and its base station [32]. In addition to computational results, he tested relay communications hardware with LCDR Sakyrd and Capt Ericson's flight test setup [32].

### ***Concurrent Research.***

As with LCDR Sakyrd and Capt Ericson's efforts, this research was conducted in conjunction with other AFIT students, each addressing a different aspect of the cooperative UAS surveillance problem. The team shared resources and knowledge with the other students, and they, in turn, contributed to the team's understanding of the system requirements.

Capt Shannon Farrell researched UAV flight paths to keep a target in the UAV's fixed sensor FOV [33]. He explored efficient orbits to keep a side-mounted camera pointed at a target, as well as flight paths to achieve desired sensor-to-target look angles from a side or front-mounted camera [33]. Capt Chris Booth developed a software algorithm to converge multiple UAVs on a single target [34]. His program calculates efficient flight paths for one to four UAVs at any starting location. It coordinates their



arrival into an orbit around the target and maintains them at equidistant spacing around the target once in orbit [34]. Capt Joe Rosal explored the optimization of UAV surveillance along a linear path, such as a road or base perimeter [35]. Austin Smith worked on the problem of UAV collision avoidance. He created a centrally-monitored deconfliction program to detect potential collisions and issue proper avoidance commands in the form of pitch, turn rate, and airspeed changes [36]. Maj Adam Lenfestey and Capt Eric Cring examined methods for building trust into automated systems. They focused on control of multiple UAVs in their study [37].

### III. Methodology

#### Systems Engineering

Presented with a basic understanding and requirement for cooperative UAS command and control capability, the team utilized a systems engineering approach to ensure the complete construction, description, and capture of a conceptual architecture and a flight test system that was used to explore and evaluate the concept of cooperative UAS control. The architecture is hereafter referred to as the Cooperative Unmanned Surveillance System (CUSS).

#### *Systems Engineering Process.*

A representative systems engineering process follows the format in Figure 2. It begins by capturing the process inputs to the system, including mission requirements, customer requirements, system constraints, and a description of the environment in which the system must operate. These requirements are then analyzed and decomposed into functional requirements to ensure a complete understanding of the functions the system must accomplish. As part of this process, performance requirements are allocated to the lowest level of functional decomposition necessary to ensure requirements traceability back to the process inputs. As functional decomposition and allocation of system requirements continue, they are also iterated through a loop with requirements analysis to ensure each function is properly tied to a system requirement. Once functional analysis has sufficiently matured, the system begins to take on physical shape as the architecture is transformed during the synthesis stage of systems engineering. Functional and

physical trade-offs continually occur during the design loop; however, the system is still compared to initial requirements to ensure it meets the necessary functionality. This entire process is iterated using a system analysis and control step until the design team arrives at a system that satisfactorily meets the requirements, goals, and constraints identified as process inputs.

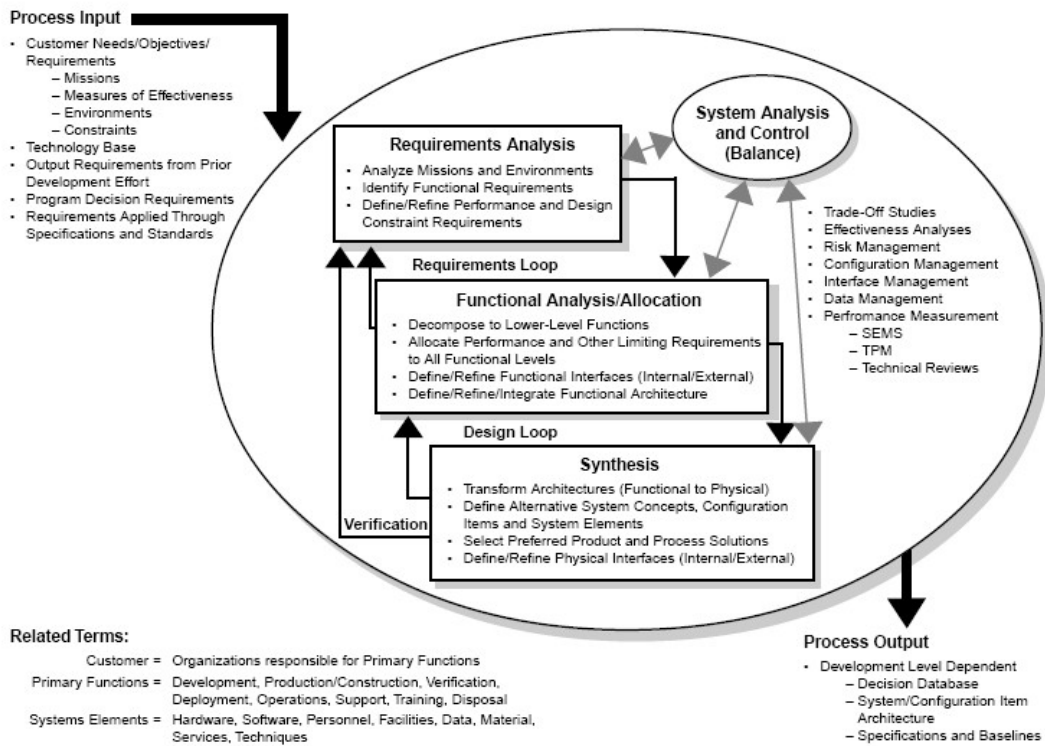

**Figure 2. Systems Engineering Process [38]**

**DoDAF.**

In addition to providing a development framework, a systems engineering approach also ensures that inherent complexities, such as those introduced by cooperative control schemes, are understood. This allows the team to maintain the technical integrity

of the architecture as it matures. To assist in this effort, the team used a subset of the Department of Defense Architecture Framework (DoDAF) to create and document the system's architecture as it evolved. The use of architectures in the development of DoD weapons systems is required by law, and supported by JCIDS [39] and the Defense Acquisition Guidebook – DoDD 5000.1 and DoDI 5000.2 [40].

The DoDAF is an integrated set of products and views where each term, definition, and relationship across the architecture is uniquely identified and consistently used. This process enables complex systems to be decomposed into, or assembled from, manageable and standardized components that support the “clarification of roles, boundaries and interfaces” between each product, and improves common understanding among stakeholders and across organizational boundaries [41:5].

#### ***JCIDS Assumptions.***

To initiate the systems engineering process, the CUSS team reviewed on-going UAV operations as well as the extensive work provided by previous research efforts and sponsored AFIT theses. This work includes the significant JCIDS analysis and the corresponding Functional Area Analysis, Function Needs Analysis, and Functional Solution Analysis documentation provided by Maj Laird, *et al.* [28]. It clearly identifies the current needs, desired capabilities, and functional gaps associated with singular UAV operations on today's battlefields for several specific use cases. The Fleeting Targets research, however, was narrow in scope and limited to a single operational scenario. Based on the capability gaps identified by Maj Laird, *et al.* and the *Unmanned Systems Roadmap*, the team assumed that a cooperative control system would enhance the UAS solution identified in the Functional Solution Analysis. The team also assumed that an

expansion of the scope of the system to include many types of surveillance tasks, rather than focusing on a single mission thread, would close more capability gaps and help achieve the *Unmanned Systems Roadmap* stated goal of increased commonality [12:4].

## **Concept of Operations**

With a clear statement of need for cooperative command and control of UASs providing the basis for the conceptual system definition, the team then focused on understanding what the system must do, where and how it will be operated, and who will operationally control and receive information derived from the system. Identifying these specific mission and user requirements associated with the concept definition was the basis of the Concept of Operations (CONOPS). This analysis and brainstorming included looking at current DoD employment of UASs, in addition to both historical and proposed future implementations of UAV platforms [42]. The team also conducted interviews with current UAS operators, Air Force Special Operations Command personnel with expertise in UAS operations, and recently deployed personnel. These first-hand accounts enabled the team to understand unique war-time requirements associated with UAS operations and capture a wide array of current and potential future missions for cooperative UASs.

The CUSS CONOPS describes the system's overall purpose, time horizon, risks, military challenges, high level synopsis of system execution, desired effects, necessary and enabling capabilities, and sequenced actions. Development of this CONOPS also provided insight into the potential implications that cooperative UAS command and

control may have in the areas of Doctrine, Operations, Training, Materiel, Leadership, Personnel, and Facilities [42]. The CONOPS is presented and discussed in Chapter IV.

## **Conceptual Architecture**

### ***System Context.***

Once the CONOPS was established, it became necessary to define the system context in which the UAS would be operating. Per Dennis Buede in *The Engineering Design of Systems*, the CUSS has two types of interactions with systems outside of its own boundary. The first is External Systems that interact and exchange information with the CUSS. In this relationship, both the CUSS and External Systems are able to impact and exchange information with one another, such as passing data to and receiving information from a node. The second of these are Context Systems which also exist outside the boundary of the CUSS, but can influence and send information to the CUSS and other External Systems. The CUSS is unable to impact or send information to Context Systems, nor change their state or behavior. These relationships are illustrated in Figure 3 [43:124]. By carefully developing the CUSS context diagram, the team created the initial scoping and limitations of the cooperative control challenge the team would address.

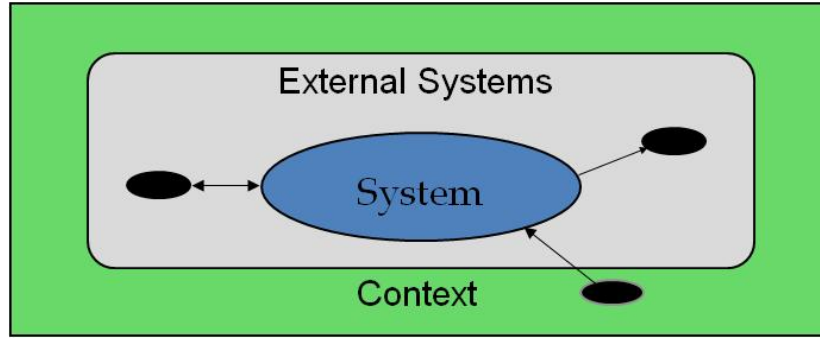

**Figure 3. External vs. Context Systems**

***DoDAF Product Choices.***

Once the boundary of the system was identified through the context diagram, the team used the DoDAF to create the necessary architecture products required to describe the conceptual system. There are four major sets of views associated with the DoDAF: the Operational Views (OV), the System Views (SV), and the Technical Views (TV) which are each supported by the All Views (AV). The All Views contain high level summary and overview information as well as an integrated dictionary that provides a glossary of each term used within the architecture. Among these views, there are a total of 29 interrelated products that can be used to fully document and describe the system under design; however, only a subset of these products is produced in most development efforts. A suggested process flow for creating each DoDAF product is found in Figure 4 [41].

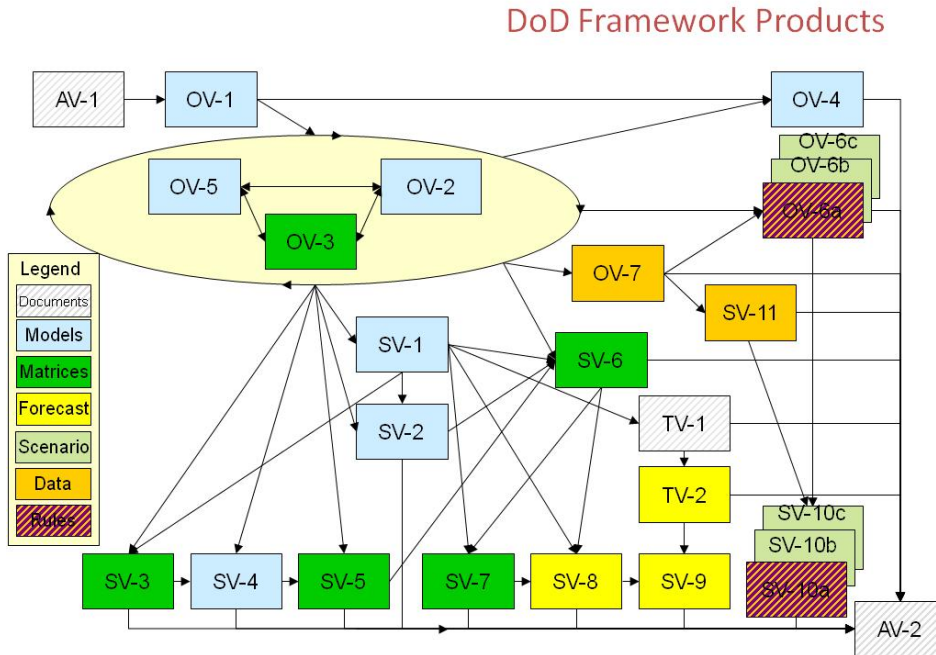

**Figure 4. Prescribed DoDAF Process Flow [44]**

Because enormous resources may be required to produce a full set of architecture products, the DoDAF is tailorable based on program requirements, scope, and overall system needs. An abbreviated DoDAF process was chosen to produce conceptual design products consistent with the system definition and context diagram. These products focused team efforts on capturing the essence of the required functionality to achieve cooperative command and control of multiple UAVs simultaneously. After the system CONOPS was finalized, the team used the sequence in Figure 5 to develop the required products for the conceptual CUSS architecture.



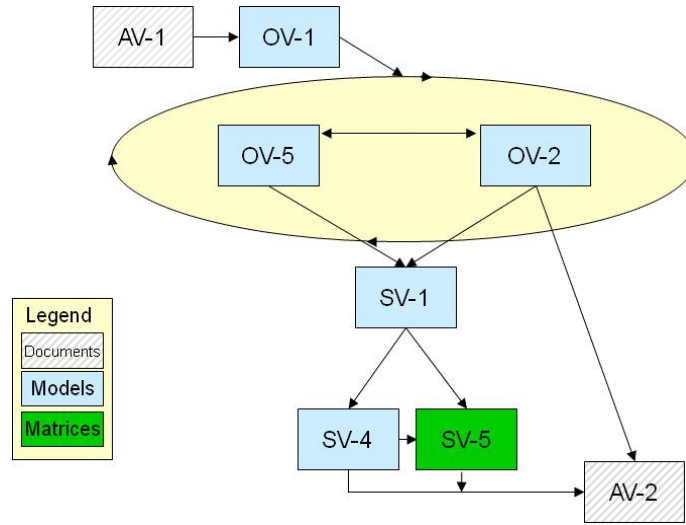

**Figure 5. Architecture Product Sequence Used [44]**

***Production of Architecture Views.***

As the team formulated the problem statement and needs associated with cooperative UAV control, this information became the AV-1, a high level overview and summary that describes the CUSS and what it is expected to accomplish at an executive level. As the architecture evolved, the AV-2 was created to define each term, entity, need line, and function identified within the architecture.

Bounded by these two AV documents, the team began development of the CUSS OV products by describing the operational elements, tasks and activities, and information flows by creating an OV-1 or High-Level Operational Concept Graphic. This view provides a quick, readily understandable description of what the CUSS is supposed to do and how it will operate [45]. It depicts the CUSS operational concept and highlights several of the main operational nodes associated with the architecture. This view also

provides insight into the system interactions between the CUSS and its environment and its interfaces with external systems.

The second OV product created for the CUSS was the Operational Activity Diagram or OV-5. This view displays the external systems that interface with the CUSS and decomposes the operational activities and capabilities required to execute the mission. For the purposes of this system, the OV-5 was decomposed through the second level of system functionality to describe the capabilities, operational activities, inputs, outputs, controls, and mechanisms that are integral to the CUSS [45]. Scenarios in the CONOPS were traced through the OV-5 to confirm that all necessary operational activities were present and no extra activities were listed.

The final OV product created was the Operational Node Connectivity Diagram or OV-2. This view graphically depicts the operational nodes or organizations that exchange information with the CUSS. These information exchanges are called needlines and they document the requirement to pass information between system and external nodes. The OV-2 includes internal and external operational nodes, and indicates which nodes conduct which operational activities in the OV-5 [45].

Once the OV-1, OV-2, and OV-5 were complete, the CUSS team initiated development of the System View architecture products to detail the physical systems and components associated with the nodes, activities, needlines, and requirements in the Operational Views.

The first system view created was the System Interface Description or SV-1. This view depicts systems nodes and the components resident at each these nodes. The SV-1 is derived from the operational views in that components and interfaces are chosen to

perform the required operational activities and facilitate information exchanges defined by the needlines.

The second system diagram created was the SV-4 or System Functionality Description. This view describes the system's functional hierarchy under its system nodes and components. Each component is decomposed into the specific system functions that component provides.

Lastly, the Operational Activity to Systems Function Traceability Matrix, or SV-5, was created to map system functions to operational activities. Within this view each operational activity is fulfilled by one or more system functions and each system function is shown to support one or more operational activities. This detailed matrix identifies components that are potentially overburdened or redundant, and gaps where operational activities are not covered by system functions within the architecture. It provides the link between the System Views and Operational Views and ensures that both are consistent.

Throughout the development of these products, extensive iteration and tracing of operational threads provided by the CONOPS was conducted to explore required system nodes, system activities, and information needs by each component of the conceptual architecture. With each iteration, the team gained a more complete understanding of the requirements, functionality, and potential implementation of the CUSS.

Systems Engineers have many commercial software tools available to create architecture products. The CUSS team used Telelogic's System Architect to develop the majority of the products described in the previous section and displayed in the Appendices. System Architect features tools that can be used to create DoDAF

architecture products and provides a Structured Query Language (SQL) database that the software uses to link these products together [46].

## **Test Architecture**

Concurrent with developing the architecture products for the conceptual system, the CUSS team initiated construction of a representative flight test system to explore the capabilities and limitations of UAS cooperative control. This system was also used to evaluate flight control and navigation algorithms under concurrent development by other AFIT research students.

### ***Airframe.***

Previous AFIT UAS research efforts utilized the SIG Rascal model RC plane fitted with an autopilot and two optical sensors. This airframe is a large scale radio-controlled airplane with a 110 inch wingspan and a four-stroke power plant. The aircraft is shown in Figure 6.



**Figure 6. SIG Rascal**

Flight testing the SIG Rascal required substantial overhead due to its size and its gas-powered engine. Furthermore, only two Rascal airframes were available for testing. Consequently, the team decided to replace the SIG Rascal with the BATCAM MAV shown in Figure 7. This V-tail UAV has a 21 inch wing span and is powered by an electric motor. The BATCAM has a smaller logistical footprint than the Rascal due to its small size and electric propulsion system. The team acquired four BATCAMs as Government Off-the-Shelf (GOTS) hardware. Though the BATCAMs were used for most flight testing, the Sig remained compatible with the control setup and was used for some single-ship algorithm testing.

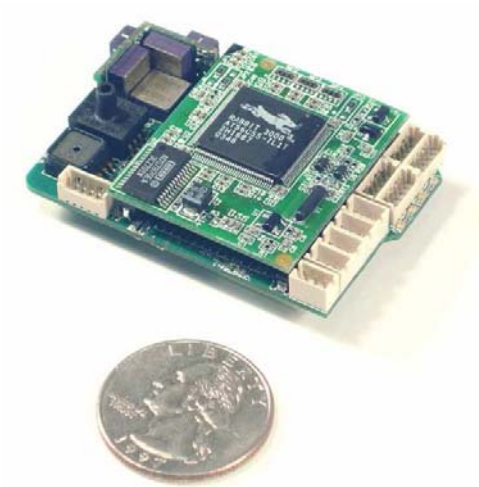

**Figure 7. BATCAM MAV**

### *Autopilot.*

The airframes included Procerus Technologies Kestrel™ autopilots, shown in Figure 8 [47]. This is the same flight control system used in the Rascal for the previous research of Sakyrd and Ericson, Terning, Vantrease, and Hansen [29; 30; 31; 32]. The

autopilot houses 3-axis rate gyros and accelerometers for sensing aircraft orientation, as well as dynamic and static pitot ports for measuring altitude and airspeed. The autopilot interfaces with an external Furuno GH-81 GPS receiver for position sensing through a serial connection and provides control surface and throttle commands through four standard RC hobby servo ports.



**Figure 8. Procerus Technologies Kestrel™ Autopilot [47]**

### ***Communications.***

The autopilot communicates through a serial cable or interface board connection with an external modem. The BATCAMs came equipped with Aerocomm AC4868 modems; however, the team replaced them with MaxStream 9XTend™ modems. This was done to maintain compatibility with the ground station Commboss (which contains a 9XTend™ modem). The 9XTend™ also has a longer range than the AC4868 and can be programmed to relay data packets. The modem transmits and receives data over a frequency-hopping spread spectrum network at 900 megahertz (MHz).

### *Sensors.*

The BATCAM airframe houses front and side mounted Charged Couple Device (CCD) cameras in a removable pod beneath the aircraft body frame, shown in Figure 9. The measured Field of View (FOV) for this camera is 48° horizontal by 40° vertical. The center of the FOV for the front camera is depressed 49° from level, while the side camera's is depressed 39°. A serial connection from the autopilot to a small power and control circuit board allows the operator to switch between the two cameras. The camera system can be set to transmit video data on one of four frequencies between 2.4 and 2.5 gigahertz (GHz).

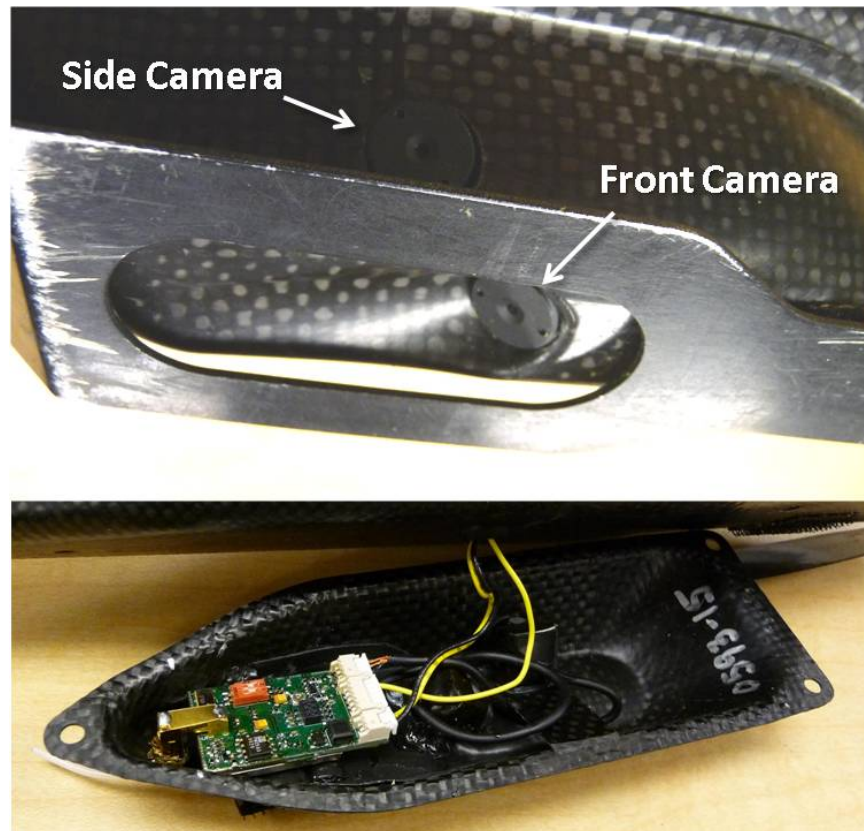

**Figure 9. BATCAM CCD Cameras and Camera Pod**



## Ground Control Hardware and Software.

The primary operator interface is the Virtual Cockpit™ software provided by Procerus [47]. An example of the interface is shown in Figure 10. It allows the operator to create and modify waypoints, save them to a flight plan, and upload them to the aircraft. The operator can monitor and control multiple aircraft with the software, including changing the navigation mode, commanded waypoint, and sensor of interest. The operator can also send manual mode commands through keystrokes or an attached game control pad. Virtual Cockpit™ also provides a video display window that interfaces with a video capture device on the host system to display sensor data. The team installed the software on a Dell Precision M6300 laptop.

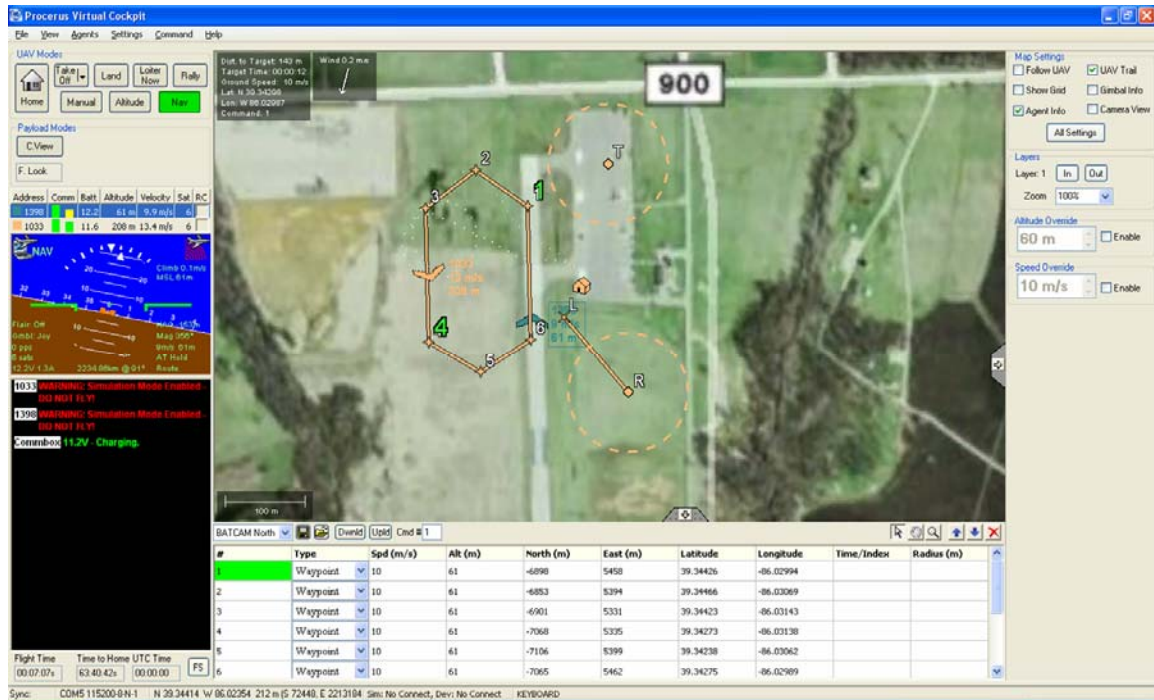

Figure 10. Virtual Cockpit™ User Interface



The operator controls Kestrel™-equipped aircraft through hardware and software produced by Procerus. The Procerus Commbox [47], shown in Figure 11, contains a MaxStream 9XTend™ Modem connected to an interface board. It has an external coaxial connection for a radio frequency (RF) antenna, and an external serial connection to interface with the ground station computer. The team used a serial-to-Universal Serial Bus (USB) cable to connect the Commbox with the laptop. The Commbox has a composite video pass through that can overlay telemetry data on the video signal. It can also connect to an external GPS receiver, providing home station position data to the control software.

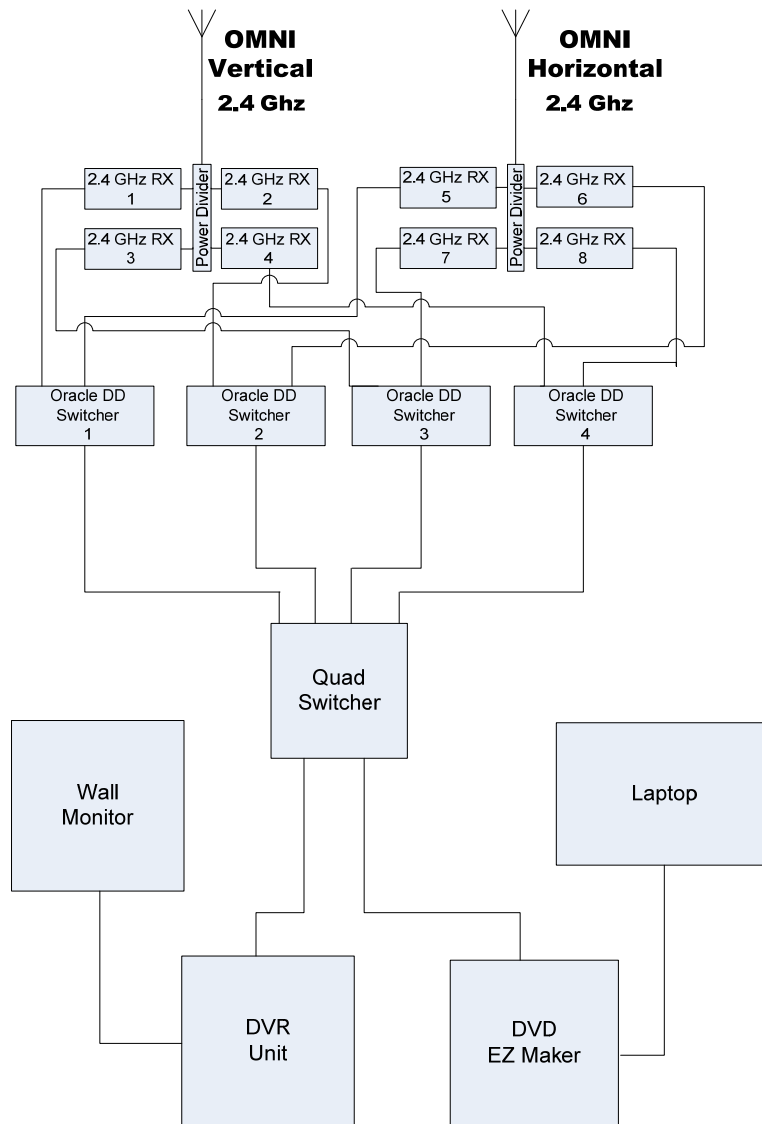

**Figure 11. Procerus Technologies Commbox [48]**

### ***Video Capture Hardware.***

The team set up a robust system to receive, display, and record video signals from four aircraft simultaneously, depicted in Figure 12. Two 2.4 GHz omni-directional antennas oriented 90° to each other (for polarity diversity) received the video signals from the BATCAMs. Each antenna was attached to a 4-way RF power divider to send the

video signals to separate receivers. Each power divider was connected to four 2.4 GHz video receivers, each set to one of the four BATCAM video transmission frequencies. The video receivers output composite video signals in National Television System Committee format.



**Figure 12. Video Capture Equipment Setup**

Each pair of receivers operating at the same frequency (but attached to different antennas) had their video signals routed through an Oracle dual-diversity video controller. The controller automatically switches to obtain the best available video signal from the two receivers on each frequency, effectively providing a spatial and polarity diversified system.

The four Oracle controllers were connected to a quad video switcher. This device combined the four signals onto one display, as shown in Figure 13. The operator can



**Figure 13. Quad Video Display**

select between displaying one signal, all four, or two signals in a picture-in-picture format. The video signal from the quad switcher was sent to a Pioneer DVR-533H digital video recorder (DVR) for recording, as well as an AVerMedia DVD EZMaker USB Plus external video capture device connected to the laptop by a USB cable. The Virtual Cockpit™ software interfaced with the video capture device so the operator could display the quad video signal on the laptop.

### ***Control Algorithm Interface.***

With the help of 2<sup>nd</sup> Lieutenant Jared Yates and Capt Chris Booth, the team developed two separate software interfaces to allow a control algorithm, written in MATLAB® code, to interface with Virtual Cockpit™. One interface was developed for Capt Booth's algorithm [34] to converge multiple UAVs on a single target, and the other was developed for Austin Smith's collision avoidance algorithm [36]. These software interfaces were written in C++, using Microsoft Visual Studio, based on the software development kit provided by Procerus for use with Virtual Cockpit™.

Each software interface interacts with Virtual Cockpit™ via a Transport Control Protocol/Internet Protocol (TCP/IP) socket connection. Capt Booth and Mr. Smith, who used the CUSS as a test-bed, wrote their control algorithms in MATLAB® code. This MATLAB® code was compiled into a dynamic link library (DLL) file that was included in the C++ code.

Upon launching each software interface, the program established a socket connection with the Virtual Cockpit™ software already running in the background. The interface program would then copy all relevant telemetry data packets sent from the autopilots to Virtual Cockpit™. Based on the needs of each user, the interface program

would extract specific data from each packet and copy this data into variables that were either displayed in the graphical user interface, used as inputs to the control algorithm, or both. Based on the output of the control algorithms, the interface program would then generate control packets for Virtual Cockpit™ to send them to one or more autopilots, directing each affected aircraft to execute the flight plan or control commands dictated by the user's algorithm.

LCDR Sakryd and Capt Ericson developed a similar user interface for their thesis work [29]. They based their interface on a Model-View-Controller architecture, dedicated specifically for the purpose of tracking a single fleeting target. Rather than basing the interface for the CUSS on the Fleeting Target Controller program, the team decided that a simpler interface developed from the Virtual Cockpit™ software development kit would be better suited for each individual project that it was intended to support. The two interfaces used were based on Procerus' software development kit and contained a significant amount of shared code, but each algorithm was unique enough in purpose to develop different programs with user interfaces tailored specifically towards each algorithm.

#### ***Hardware and Software-in-the-Loop Simulation.***

The flight test setup was augmented by a configuration allowing the team to perform software-in-the-loop (SIL) and hardware-in-the-loop (HIL) testing in the laboratory. The Aviones UAV Flight Simulator software was the primary facilitator for SIL and HIL testing. Aviones is an open source research tool developed by the Brigham Young University Human Centered Machine Intelligence and Multiple Agent Intelligent

Coordination and Control laboratories [49]. Procerus Technologies provided DLL files for using Aviones with the Virtual Cockpit™ and Kestrel™ systems.

In SIL mode, Aviones simulated the aircraft physics. It also simulated autopilot control loops through the Procerus DLL files. Aviones communicated with Virtual Cockpit™ through a TCP connection, simulating the communication path through the Commbox and aircraft modem. Aircraft physics parameters and simulated winds could be changed by modifying variables in text files Aviones reads upon initialization. Figure 14 depicts the SIL setup.



**Figure 14. Software-in-the-Loop Setup**

For HIL mode, Aviones simulated aircraft physics only. The Kestrel™ autopilot received simulated sensor inputs (gyro, accelerometer, and pitot/static) and GPS data from Aviones through two USB-to-serial connector cables. It generated its own control commands which it passed back to Aviones through one of the USB-to-serial cables. The autopilot communicated with Virtual Cockpit™ through the Commbox, as it would in actual flight. Figure 15 depicts the HIL setup.

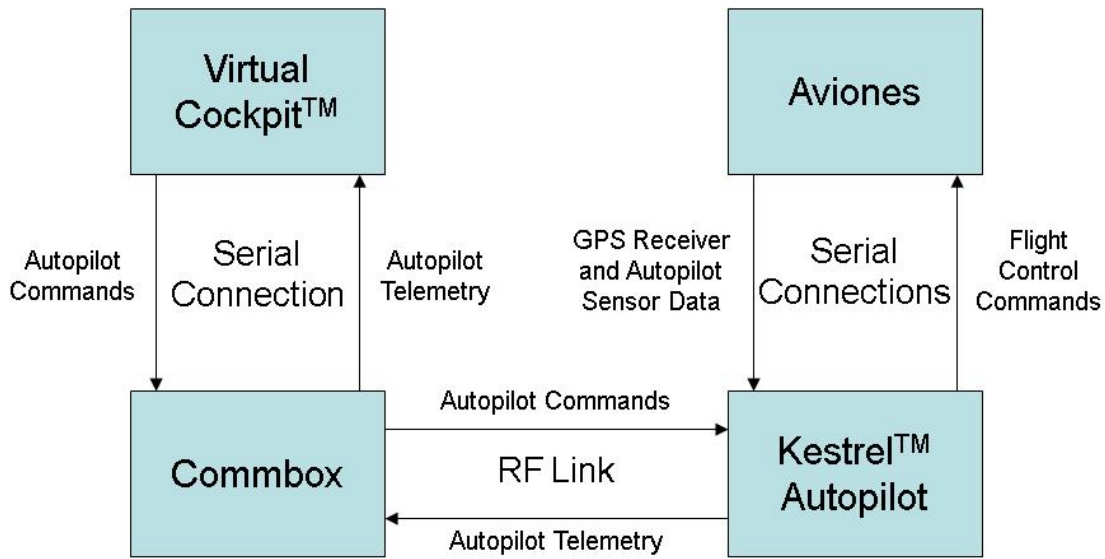

**Figure 15. Hardware-in-the-Loop Setup**

## Flight Testing

Due to current Federal Aviation Administration (FAA) limitations that restrict all UAV flight test activities by U.S. Government agencies within the National Airspace System (NAS), the team was required to use restricted airspace for all flight tests. To comply with this requirement, the closest restricted airspace to AFIT suitable for UAV testing is the Camp Atterbury Joint Maneuver Training Center located near Edinburgh, Indiana. An overview of the testing grounds is shown in Figure 16. Camp Atterbury is located about three hours from Dayton, Ohio and has been used extensively by both AFRL and AFIT to conduct UAV flight tests and evaluation of advanced navigation technologies [31]. To prepare for each flight test, the team contacted Camp Atterbury and coordinated the use of the aircraft parking ramp next to the Camp Atterbury runway



and control tower. This communication was necessary to ensure both airspace and frequency deconfliction during all periods of active UAV flight testing.

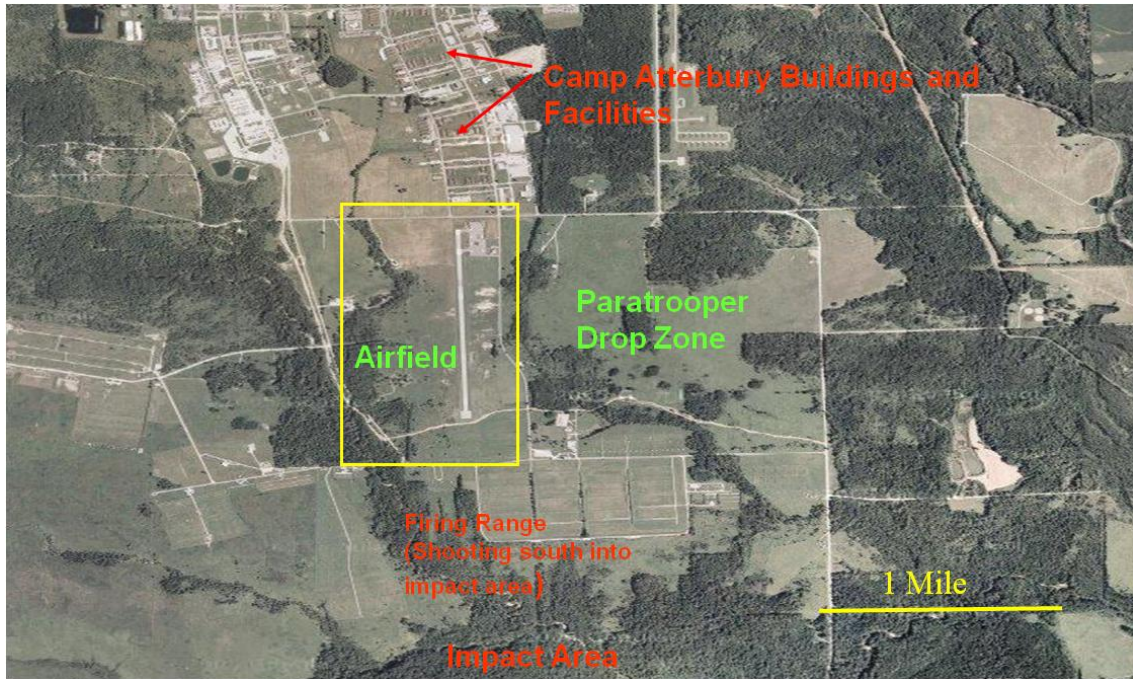

**Figure 16. Camp Atterbury Joint Maneuver Training Center**

Prior to each flight test, the team briefed proposed flight test activities to a Technical Review Board (TRB) and concurrently briefed a Safety Review Board (SRB) to ensure both the team’s test objectives and safety procedures were sufficient. In addition to the TRB/SRB, the team prepared flight test cards that detailed the specific steps and procedures to be executed during the flight test and developed checklists for inventorying and setting-up ground and flight test equipment. Team members also conducted extensive ground based dry runs of each test event to ensure both personnel and equipment used during the flight test were available and fully operational. Personnel



from Cooperative Engineering Services Incorporated (CESI), a company contracted by AFIT's Advanced Navigation Technology laboratory, assisted the team in ground and flight testing by providing ground support, RC pilot expertise, and the use of their 20 foot self-contained and enclosed operations trailer from which to conduct flight test activities. Once the dry run was satisfactorily completed, the team loaded the trailer with all required equipment and necessary spare parts for the flight test.

On the day of a test, the team would arrive at Camp Atterbury and check-in with Range Control and the Airfield to pick up radios to maintain communications throughout the day and to see if there were any last minute range restrictions or current operations that would impact the flight test. Once this was complete, the team would proceed to the aircraft parking ramp and begin setting up the flight test equipment and operations trailer in accordance with the schematic in Figure 17.

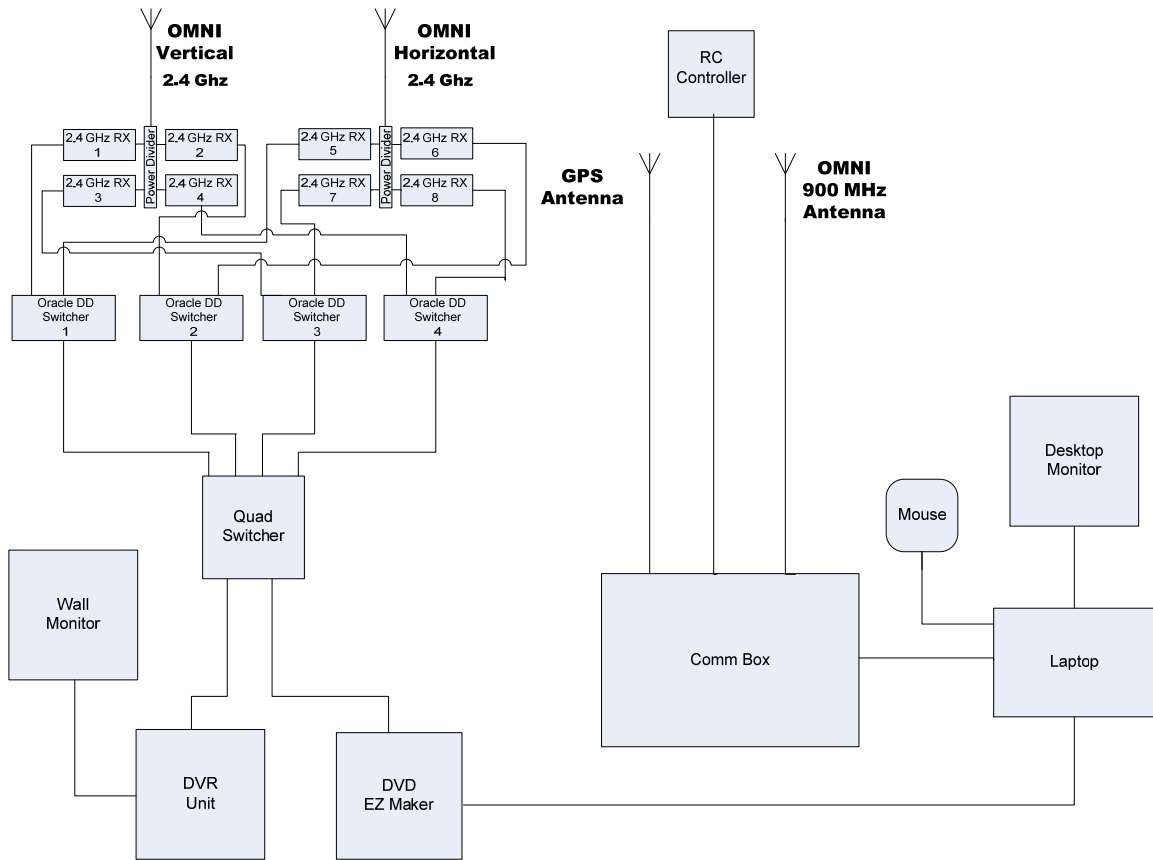

**Figure 17. Flight Test Hardware Schematic**

Figure 18, Figure 19, and Figure 20 show the fully assembled test ground station equipment within the CESI operations trailer.



**Figure 18. Laptop and Monitor**



**Figure 19. Quad Switcher, DVR, Wall Monitor, and Commbox**

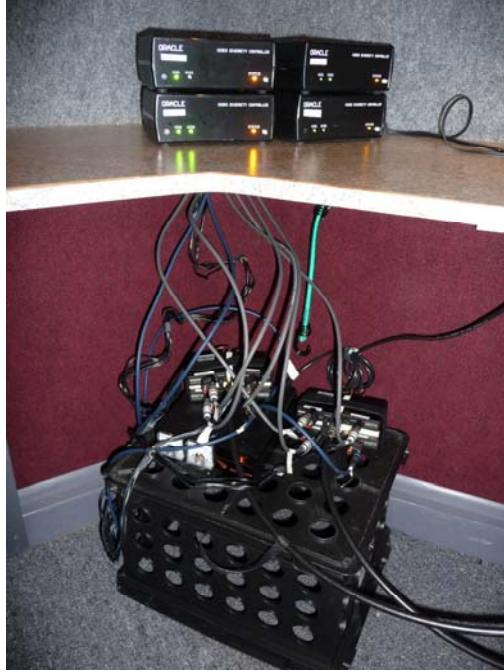

**Figure 20. Video Receivers and Dual Diversity Controllers**

All antennas, to include the Commboss, GPS receiver, and analog sensor receiver antennas, were externally mounted to the mast structure at the front of the trailer as shown in Figure 21. Each aircraft was prepared for pre-flight check out and operation in accordance with checklists produced by the team. Once the trailer and UAV's were fully assembled, all team members met for a safety brief and review of the flight test objectives for the day. Upon completion of these briefings, the team would commence testing.



**Figure 21. Trailer Mast and Antennas**

Over the course of this research, the CUSS team conducted five full days of flight testing over a period of six months. The first two flight tests occurred during September and October of 2008 and allowed the team to become comfortable with BATCAM launch and recovery operations and begin to understand the individual flight characteristics of each BATCAM vehicle flown. To ensure optimal integration of the Kestral™ autopilot with the BATCAM, an extensive tuning process was followed to ensure proper UAV control. During autopilot tuning, the trim settings of each BATCAM were determined in addition to tuning the inner and outer control loops. Waypoint, loiter navigation, and other user defined settings were also tuned to ensure effective operation and control of the BATCAMs. Once the team was satisfied with the tuning parameters, these settings were

uploaded to each aircraft and then test flown to ensure nominal operation. This tuning process also allowed the team to gain extensive experience with operating the Virtual Cockpit™ interface and to demonstrate the video downlink capability of each vehicle. On the second day of flight testing, the team managed to launch and simultaneously fly two aircraft, a first for AFIT.

The next two flight tests occurred in November and December of 2008. The primary purposes of these tests were to simultaneously fly up to four BATCAMs and demonstrate the capability of simultaneously receiving video feeds from each vehicle. The first of these two flight dates enabled the team to begin testing Capt Farrell's Sensor Aimpoint algorithm [33] and Capt Booth's Cooperative Control algorithm [34]. On the first of these dates, the team successfully launched and simultaneously flew four BATCAMs in a racetrack pattern at Camp Atterbury. The team also demonstrated cooperative control behavior during the December flight test through the use of Capt Booth's algorithm that generated navigation waypoints and then commanded two or three BATCAM UAVs to fly to the generated waypoints [34]. The Sig Rascal was also used during the December flight test to gather data for Capt Farrell's algorithm from a different aircraft [33].

The final flight test occurred in February of 2009. The purpose of this test was to conduct further evaluation of Capt Booth's Cooperative Control algorithm [34], initial flight testing of Mr. Smith's Collision Avoidance algorithm [36], benchmark flight testing of the endurance of the a larger battery for the BATCAMs, and an initial evaluation of the time required to recover and re-launch a UAV in support of an extended mission.

## Technological Risks

During the development of the conceptual architecture and flight testing of the BATCAMs, the team identified a number of limitations, issues, and risks that could impact the operational future of cooperative control systems. The team will discuss and evaluate these risks in the *Results* section of this thesis and, where applicable, propose mitigation strategies to reduce or eliminate these risks. Some risks or issues may be outside the scope of this thesis and will be proposed as follow-on or future research work.

## IV. Results

### Concept of Operations

When presented with the problem of obtaining real-time ISR from a portable system with links to outside support elements, the team first researched current fielded capabilities and perceived capability gaps. The team also researched the work of previous groups whose theses focused on similar areas.

The team then developed a CONOPS, shown in Appendix B, describing what capabilities the system would address, what missions the system would fulfill, and what functions the system would perform. The initial focus was on a few proposed operational scenarios. In documenting these scenarios, the team first constructed the sequenced actions of various missions that the system would be expected to perform. An example of an employment scenario from the CONOPS is *Surveil a Stationary Target*:

"A user wishes to surveil a stationary target. The user creates a mission plan, deploys the CUSS, and prepares the UAVs for flight. Once the mission plan is complete and approved, the plan is transmitted to the UAVs via the [Ground Communication Hardware (GCH)]. After UAS deployment, the [Computing Device (CD)] interfaces with the UAV autopilots to guide the UAVs to the target location. Upon reaching the target location, the UAVs perform a search, acquire the target, and set up a loiter flight pattern in accordance with the mission plan or as designated by the user. The UAVs maintain surveillance and sensor coverage of the target. At the end of the mission, the UAVs are re-tasked or returned to their designated recovery location."

While over the designated target, the user may change the UAV and sensor parameters to minimize the chance of detection of the UAVs or to obtain better sensor geometry or resolution of the target. These changes can be accomplished either through sensor control commands, UAV flight commands or both. Depending on the type and scope of changes made by the user, a new mission plan may be generated and sent to the UAVs."



The employment scenarios section of the CONOPS also addresses the following scenarios: *Surveil a Moving Target; Reconnoiter Ahead of a Moving Target; Provide Surveillance of a Series of Waypoints; Conduct a Broad Area Search; and Conduct a Search for a Target.*

After laying out these employment scenarios, the group abstracted a number of functions common to multiple tasks, which are listed as general system functions of the sequenced actions section. An example of a general system function is *Plan Mission*:

"The user begins the development of a mission plan by taking user defined inputs such as ISR data, mission tasking, mission data, airspace control measures, target list, UAS flight status, and an asset list and entering these into CUSS software hosted on the Computing Device (CD). The software then develops and generates a mission plan that when executed, will achieve the overall mission objectives. Once the mission plan is complete, the CD sends the information via the Ground Communications Hardware (GCH) to the UAS. The mission plan is typically uploaded to each UAV before launch but real-time updates to the mission plan can be forwarded to UAVs at any time after launch."

The general systems functions section of the CONOPS also addresses the following scenarios: *Deploy System; Replan Mission; Manage the UAVs; Control Sensors; Manage Surveillance Data; Manage Health and Status of UAVs; Recover the System; and Conduct Post Mission Actions.* From these scenarios, the team built a conceptual architecture for the CUSS.

## **Conceptual Architecture**

### ***AV-1.***

The *AV-1 Overview and Summary Information* is shown in Appendix C. The CUSS is a composite architecture of systems, components, and communication links that

enables UAVs to work in cooperative formations. By exploiting the capabilities offered through cooperative control, the UAS can accomplish a wide variety of missions faster and more effectively than is possible with a single UAV.

#### ***AV-2.***

All terms associated with the conceptual architecture are captured in the *AV-2 Integrated Dictionary*. Terms are listed in alphabetical order in Appendix D, and include the description, type, and associated view(s). This product provides textual definitions for the elements of the architecture products, and ensures that terms are not used to describe multiple concepts.

#### ***OV-1.***

Several key employment scenarios from the CONOPS and system characteristics were captured in the High-level *OV-1 Operational Concept*, in Figure 22 below. One key aspect of the system depicted is that CUSS *Airborne Control Unit* components are not specific to a single type or family of UAVs. The system is scalable from man-packable variants up to larger and longer endurance platforms on the scale of the Predator and Global Hawk UAVs. Similarly, the *Ground Control Unit* hardware and software is scalable from a single user equipped with a laptop, to a robust control center with desktop computers and multiple monitors. The OV-1 shows two methods of extending communications range to beyond line-of-sight: relaying data through CUSS equipped UAVs, and sending data through a dedicated communications relay. Also, it depicts links to external systems like GPS and Theater HQ which provides C2ISR.

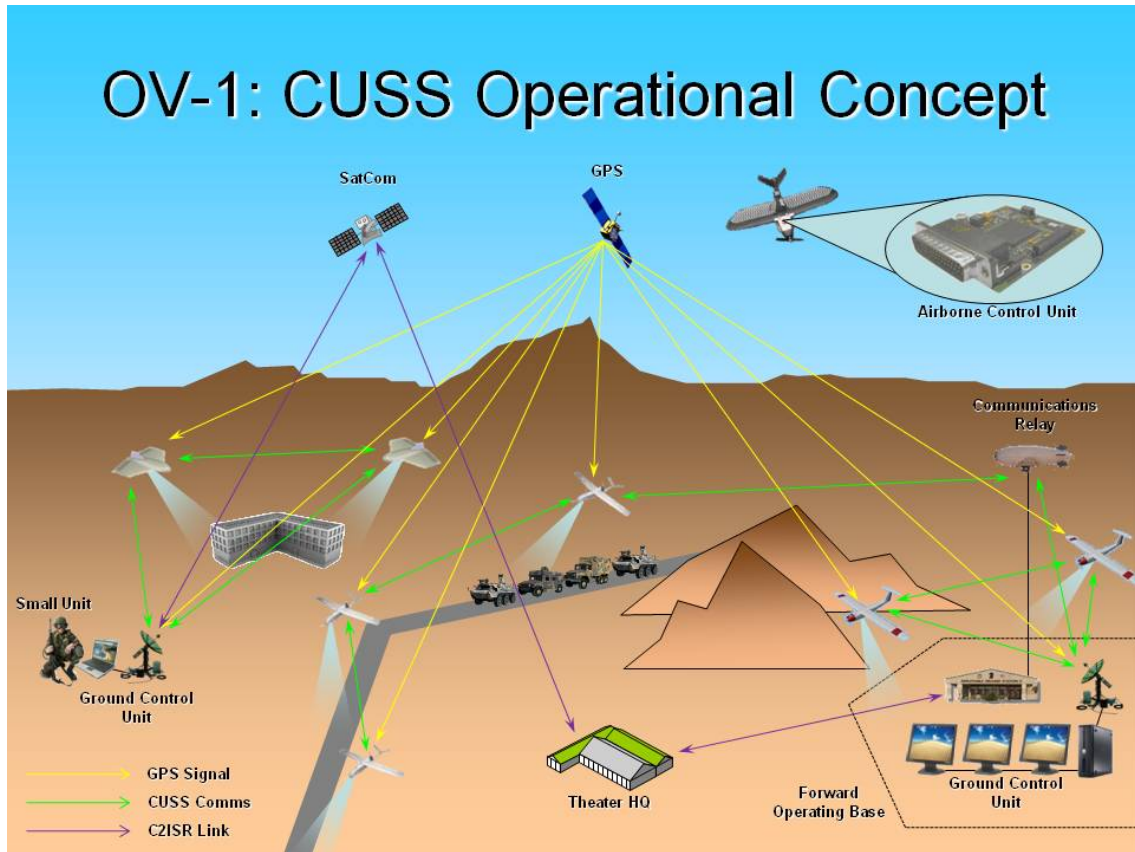

**Figure 22. CUSS OV-1 Operational Concept**

The OV-1 also shows the system performing a variety of missions from the CONOPS. The first employment scenario is the small unit or tactical operator requiring persistent surveillance of a building or target of interest. This forward-based operator may receive taskings from Theater Headquarters (HQ) or surveillance requirements may be self-generated. Once tasked, the operator creates a mission plan with the CUSS Ground Control System, uploads the mission plan to the Airborne Control Units onboard the UAVs and launches each aircraft. Once airborne, the UAV travels to its designated target location using precision navigation from GPS satellites and initiates data collection once it reaches the desired target. Control of the UAV sensors may be automatic in

accordance with the mission plan, or manually controlled by the operator. The airborne platforms are in constant communication with the CUSS ground station and with each other platform in the formation. This ensures system awareness and precise positioning relative to the target and other platforms in accordance with the mission plan. The system exhibits cooperative behavior by allocating ISR data collection requirements among the vehicles to maximize data collection. As intelligence is collected, the operator can view the data real-time and also export the surveillance product via satellite communications (SatCom) link back to Theater HQ, a Forward Operating Base (FOB), or higher command authorities as required.

Another operational thread shown in the OV-1 is the ability to provide route surveillance along Main Supply Routes (MSRs) and Lines of Communication (LOCs) for convoy operations. In this scenario, the UAVs are tasked, launched, and then directed to intercept the designated convoy by personnel from a FOB. Due to the long-range nature of this operation, CUSS equipped platforms can function as relays to extend UAV range when operating beyond line-of-sight from the launch or control location. The CUSS is equipped with a beacon following capability that enables the UAVs to adjust their positions based on the behavior of the convoy. At the end of the mission, the UAVs are directed to return to their recovery location at the FOB.

The last operational concept displayed in OV-1 is the use of a UAS to provide perimeter surveillance of a FOB. The UAVs can be tasked by the user to fly pre-determined waypoints that provide situation awareness and identification of threats outside the base wire. This mission would likely specify optimal spacing among available assets to maximize re-visit time along all areas of the perimeter. As real-time

threats or targets are identified, the user can manually re-task a platform within the formation to investigate the threat. Remaining UAVs would adjust formation spacing to optimize re-visit time. Once the re-tasked UAV has completed its mission, the user can direct a formation re-join, and formation spacing would once again adjust to optimize revisit time. Data collected in this scenario, like previous scenarios, is available to Theater HQ and other distributed users as required.

#### ***OV-5.***

After completing the OV-1, the team began the process of understanding the discrete operational activities that the system must perform to execute the wide variety of mission threads and alternate flows identified within the CONOPS. The team began functional decomposition by identifying the external systems with which the CUSS must interface to provide a cooperative control capability. This analysis provided systems boundaries and scoped the complexity of the effort. The *External Systems Diagram*, shown in Figure 23, details each external system that either sends to or exchanges information with the CUSS to accomplish its core activity of *Provide Surveillance* for system users.

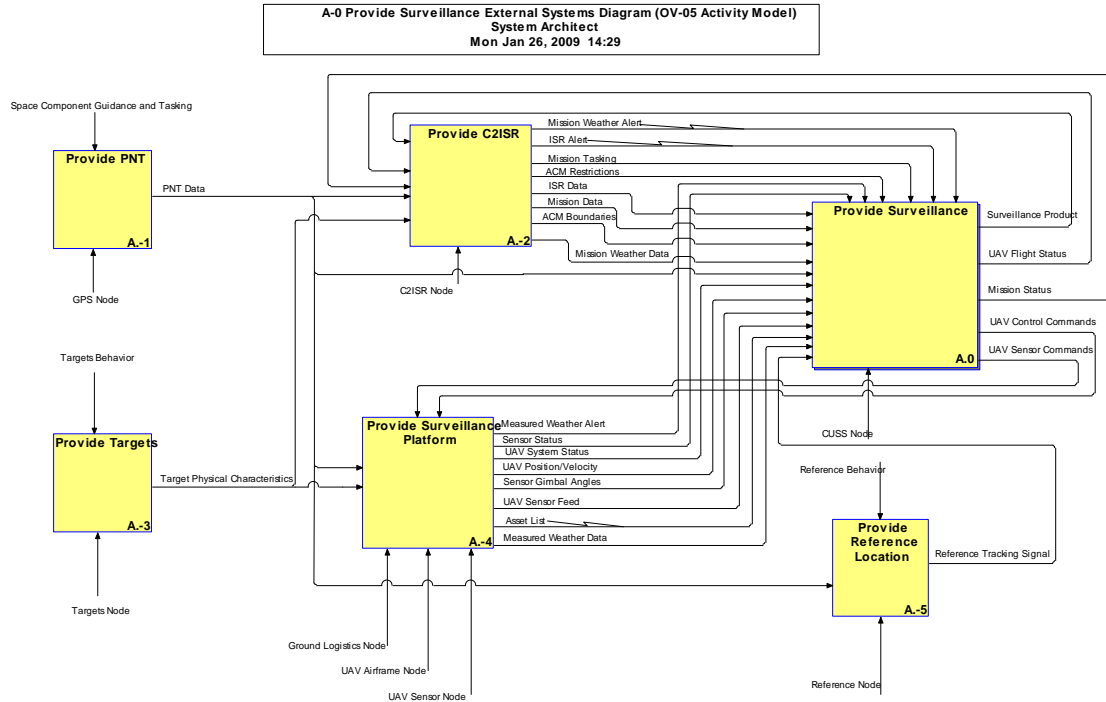

**Figure 23. CUSS A-0 External Systems Diagram**

The primary interfaces required for the *Provide Surveillance* operational activity include the following: receiving precision navigation data from the *Provide PNT* operational activity; receiving mission taskings and relevant information related to mission planning and execution from the *Provide C2ISR* (Command, Control, Information, Surveillance, and Reconnaissance) operational activity; interfacing with the *Provide Surveillance Platform* operational activity to control vehicles and sensors; interfacing with the *Provide Surveillance Platform* operational activity to capture mission data; interaction with the *Provide Surveillance Platform* operational activity to handle launch, recovery, and maintenance activities associated with the aerial platform and on-

board sensors; and, if conducting a beacon following mission, receive a reference beacon signal from the *Provide Reference Location* operational activity. Inputs, Controls, Outputs, and Mechanisms (ICOMs) flow between each of these operational activities to provide the interactions necessary to achieve desired functionality for a variety of CUSS missions.

Once the CUSS was sufficiently bounded by its connections with external systems, the team decomposed the *Provide Surveillance* operational activity to the second level of functionality, ensuring each aspect of the systems activities, interactions, and capabilities were fully understood. Beginning with the employment scenarios located in Appendix B of the CONOPS, the team traced each mission thread from initiation through completion, capturing all required activities. This mission tracing revealed a more complete understanding of mission needs and verified the CUSS was capable of providing the required functionality for each scenario. To illustrate this process, the first employment scenario within the CONOPS, *Surveil a Stationary Target*, will be traced through the CUSS conceptual architecture. During this illustration, the primary flow with only a few contingencies will be followed; though, an extensive number of alternate flows are possible within this employment scenario.

Using the A0 level of the OV-5 decomposition for the CUSS found in Figure 24, there are four first-level operational activities required to *Provide Surveillance: Plan Mission, Manage UAVs, Control Sensors, and Manage Surveillance Data*.

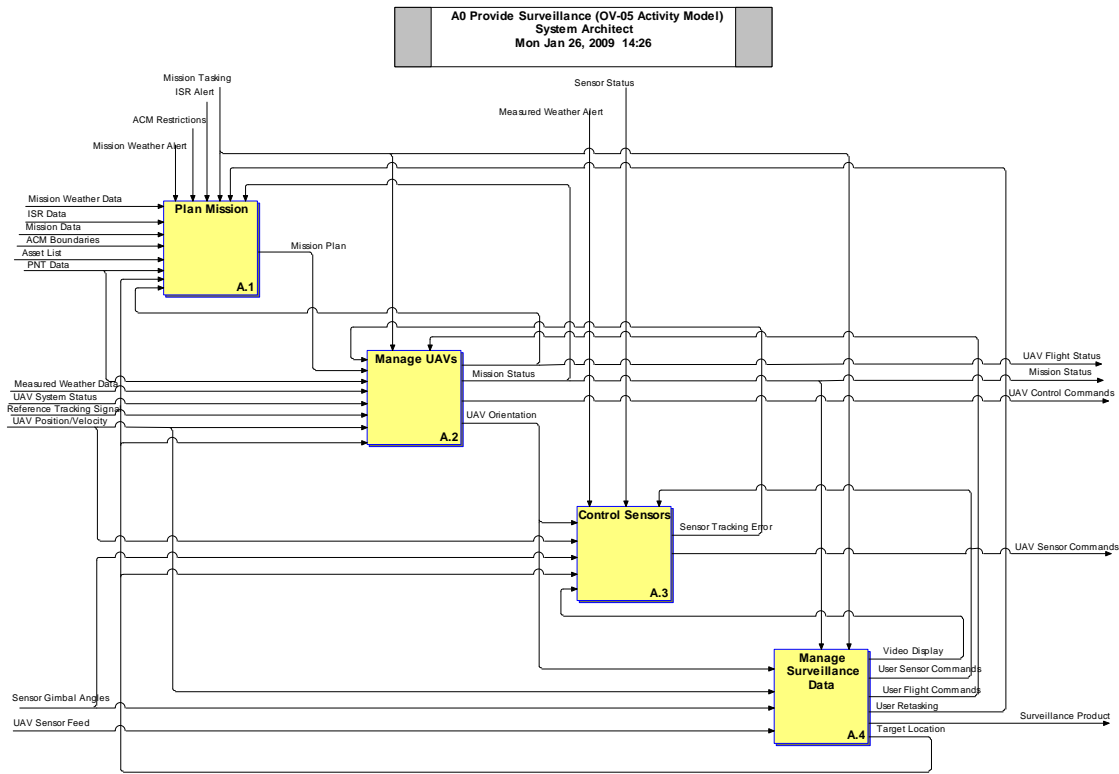

**Figure 24. OV-5 A0 Provide Surveillance**

Within this employment scenario the target is a fixed facility that requires ISR collection. The first step in this mission is for the *C2ISR Node* to task a forward-deployed operator to provide persistent surveillance on this facility. This notification and collection requirement would likely come through a SatCom link.

Beginning with the *A1 Plan Mission* operational activity in Figure 25, the operator initializes his CUSS and receives target coordinates, the types of sensor data to be collected, the date and times of required collection, and other relevant data associated with the mission tasking such as historical ISR data, weather conditions, threats over the target area, and airspace restrictions. The operator also obtains a list of available UAV



and sensor assets in addition to *PNT Data* from GPS satellites to determine the home location.

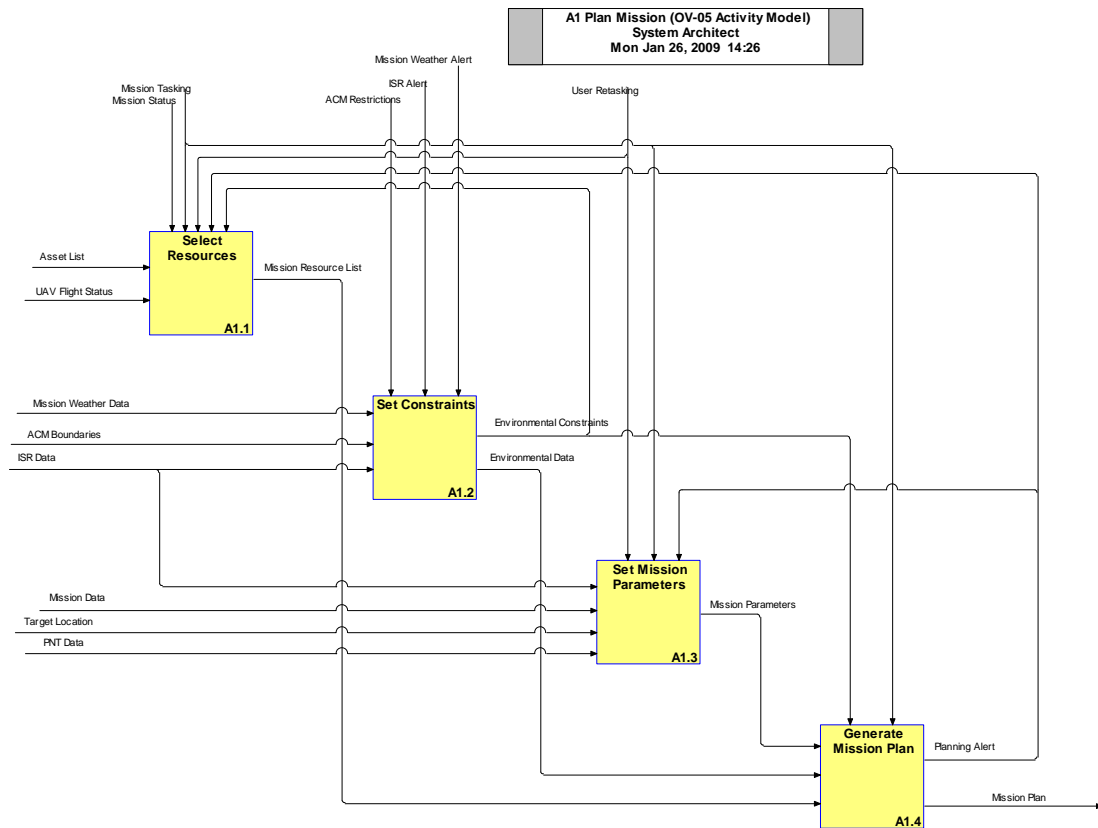

**Figure 25. CUSS OV-5 A1 Plan Mission**

The CUSS consumes this data by stepping through the second tier operational activities of *Plan Mission: Select Resources*, *Set Constraints*, *Set Mission Parameters*, and *Generate Mission Plan*. After comparing mission tasking against available resources, constraints, and parameters, the CUSS would create a *Mission Plan* that fully meets the objectives of the original tasking. If at any point the system determines that there is a constraint that conflicts with *Mission Tasking*, a *Planning Alert* is sent to the

operator. The operator can acknowledge and override the alert or modify a parameter of the *Mission Plan* to address the alert.

Once the *Mission Plan* is complete, flight assets are readied and launched at the time(s) specified by the plan. After each UAV is airborne and enroute to the target, the operator transitions to ensuring the proper management and operation of the UAVs.

Within the *A2 Manage UAVs* operational activity found in Figure 26, the CUSS uses *PNT Data* and *Telemetry Data* received from the UAVs to continuously evaluate the overall *Mission Status* in comparison with the *Mission Plan* and to monitor individual *UAV Flight Status*. During all active flight times, mission and flight status information is

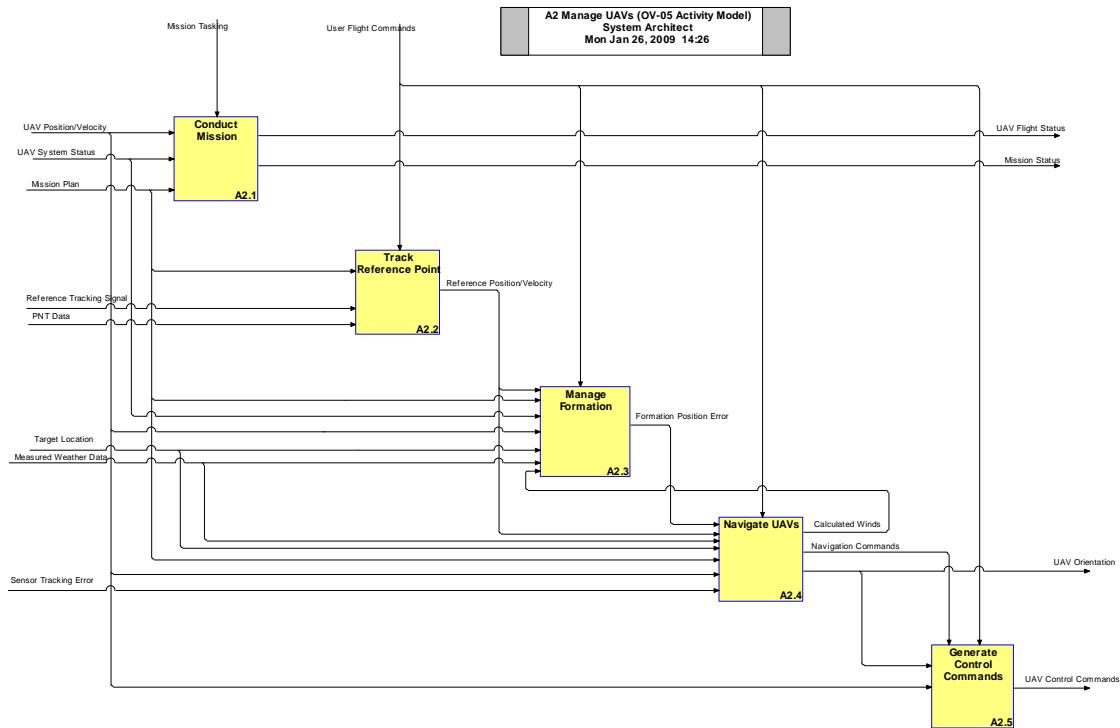
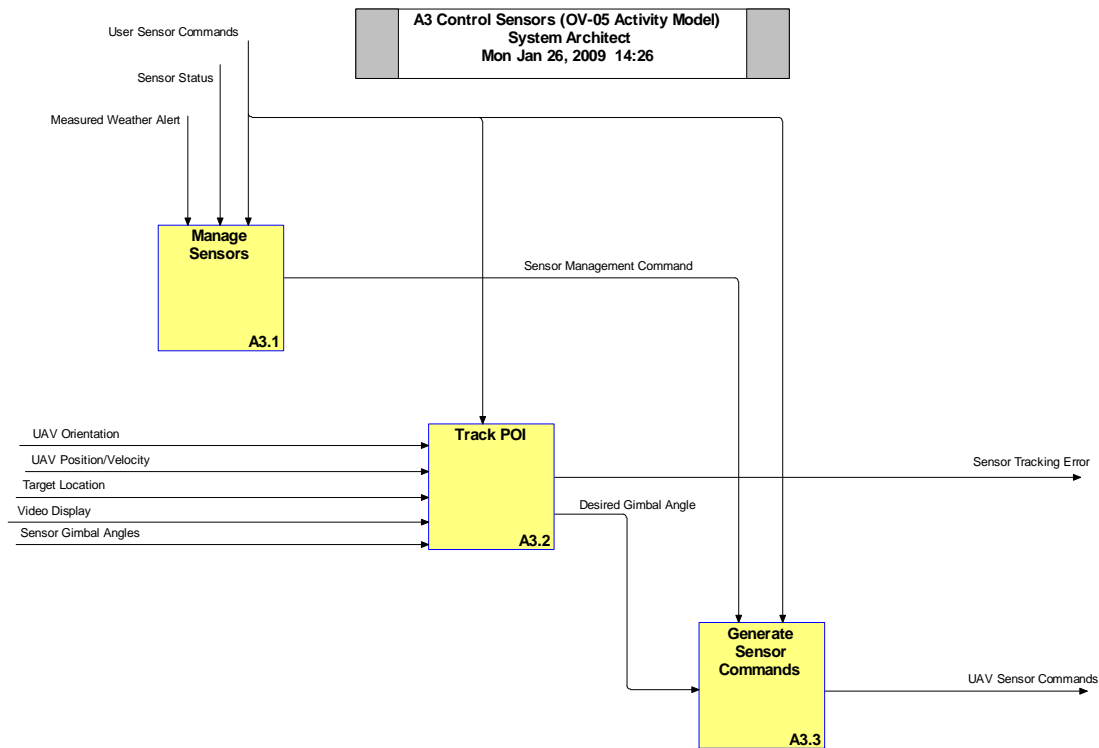

Figure 26. CUSS OV-5 A2 Manage UAVs

continuously relayed to the *C2ISR Node* to provide situational awareness in addition to forwarding collected *ISR Data* once the UAS reaches the target facility. Because the *Mission Plan* is a static entity, changes in UAV flight performance, user inputs, or *Mission Tasking* may require the creation of a new *Mission Plan*.

During persistent surveillance around the facility under observation, the CUSS monitors the precise position of each UAV within the formation in relation to the target position. It generates a desired formation position for each UAV to optimize parameters such as spacing between aircraft and sensor orientation with respect to the target. The *Navigate UAVs* operational activity uses errors in the desired formation position and other constraints from the mission plan to generate *Navigation Commands* for each individual airborne platform. The *Navigate UAVs* operational activity also adjusts for weather conditions such as wind and for *Sensor Tracking Errors* to maneuver the aircraft to keep the target in the sensor FOV. *Navigation Commands* are translated into *UAV Control Commands* to cause the aircraft to fly in the desired manner. These *UAV Control Commands* are then sent to the UAVs control surfaces and propulsion system to be acted upon.

Once the UAS begins data collection, sensor pointing and tracking become paramount. The *A3 Control Sensors* operational activity found in Figure 27 is decomposed into the operational activities of *Manage Sensors*, *Track Point of Interest (POI)*, and *Generate Sensor Commands*. The system uses these operational activities to ensure optimal sensor placement.

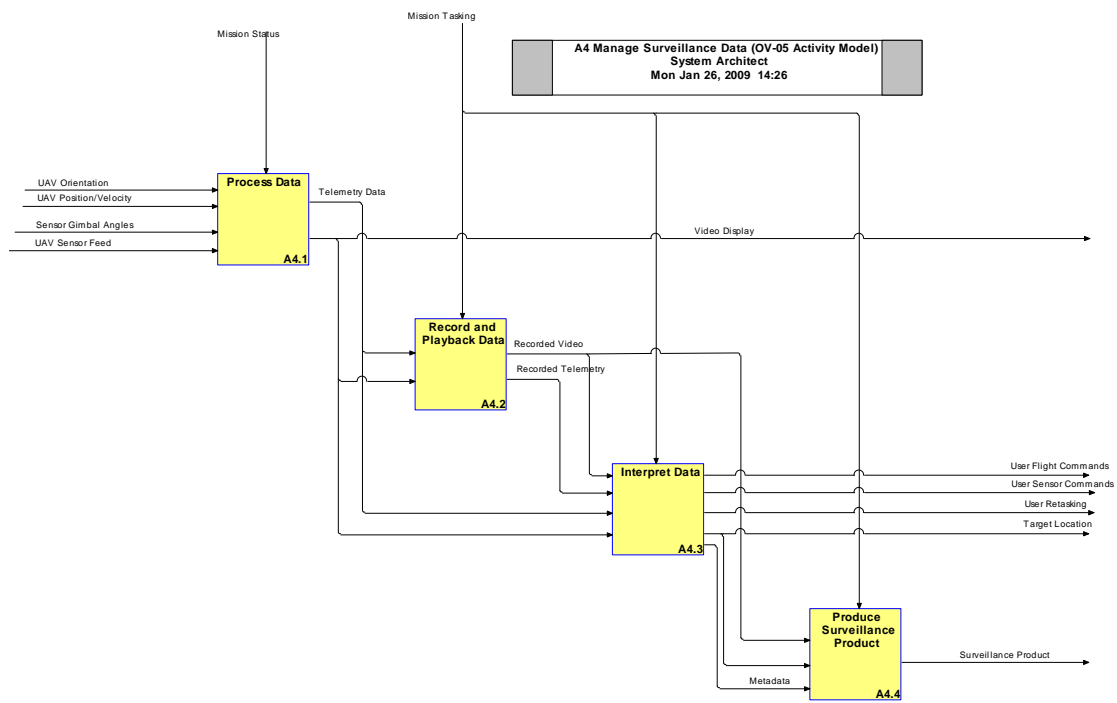

**Figure 27. CUSS OV-5 A3 Control Sensors**

The CUSS compares *UAV Position* and *Orientation* to *Target Location* data to determine the proper *Sensor Gimbal Angles* to keep the target in the sensor FOV. The system sends *Sensor Tracking Error* signals to the *Manage UAVs* operational activity to adjust *UAV Orientation*, and it uses *Desired Gimbal Angle* to generate commands to optimally point the sensors. The user also has the ability to view real-time data collected by the sensors via the *CUSS Computing Device* and can make manual inputs that affect both UAV positioning and sensor pointing if an object of interest is detected and requires further evaluation. Additionally, if the system detects conditions that impact the sensor, such as external icing, internal over-heating, or low voltage conditions, the CUSS alerts

the user of the condition. If pre-determined fail-safes are met, the system autonomously generates *Sensor Management Commands* to protect sensor assets, or these commands can come from user inputs.

As the UAS collects intelligence on the target facility, a key capability of the CUSS is processing and displaying collected data to distributed users. Accordingly, the *A4 Manage Surveillance Data* operational activity in Figure 28 is decomposed into the operational activities of *Process Data*, *Record and Playback Data*, and *Produce Surveillance Product*.



**Figure 28. CUSS OV-5 A4 Manage Surveillance Data**

The system provides the collected data real-time to the operator via a *Video Display*. Each UAV sensor feed can be viewed individually or as a composite picture to provide situational awareness of the entire facility. The system records the sensor feeds, so that the operator can review them systematically or individually if the operator detects an event of interest within a specific sensor FOV.

The operator interprets the incoming data, and generates *User Flight Commands* and *User Sensor Commands* to affect the conduct of the mission based on the data received. The system also interprets the data to derive *Target Location* from collected information and associate *Metadata* from the aircraft telemetry with the corresponding *Video Display*. The user can input *Metadata* derived from the *Video Display* such as target identification. The recorded sensor information and generated *Metadata* is used to create finished *Surveillance Products*, such as annotated imagery, that are exportable to the *C2ISR Node* and other distributed users to evaluate mission success and create requirements for subsequent missions.

At the conclusion of the mission, the UAVs are directed to return to their recovery location in accordance with the *Mission Plan*, and navigate there through the *Manage UAVs* activity. The operator can then discontinue use of the CUSS until receipt of the next mission tasking.

By tracing each of the employment scenarios in the CONOPS and alternate flows, the team verified and refined required operational activities, capabilities, and ICOMs integral to the CUSS. Within this breakdown, general systems activities were identified such as system deployment, UAS launch and recovery, mission re-planning, and post-mission maintenance and repair which are a recurring part of every mission. This process

ensured the CUSS was robust, flexible, and responsive to a wide variety of potential user needs and requirements.

### ***OV-2.***

After the OV-5 was complete, the team created the OV-2 or *Operational Node Connectivity Description* in Figure 29. This diagram depicts each operational node and describes the primary information flows, or needlines, that exist between these nodes. Within this figure, information flows can be directionally traced between the originating node and the receiving node. In some cases, information may pass back and forth such as between the CUSS and the *UAV Sensor Node*. In other cases information is unidirectional such as the CUSS receiving a *Reference Tracking Signal* without providing any information back to the *Reference Node* emitting the signal. Each of these nodes represents an organizational entity that carries out the operational activities specified within the OV-5. The corresponding activities are listed inside the node bubbles in Figure 29.

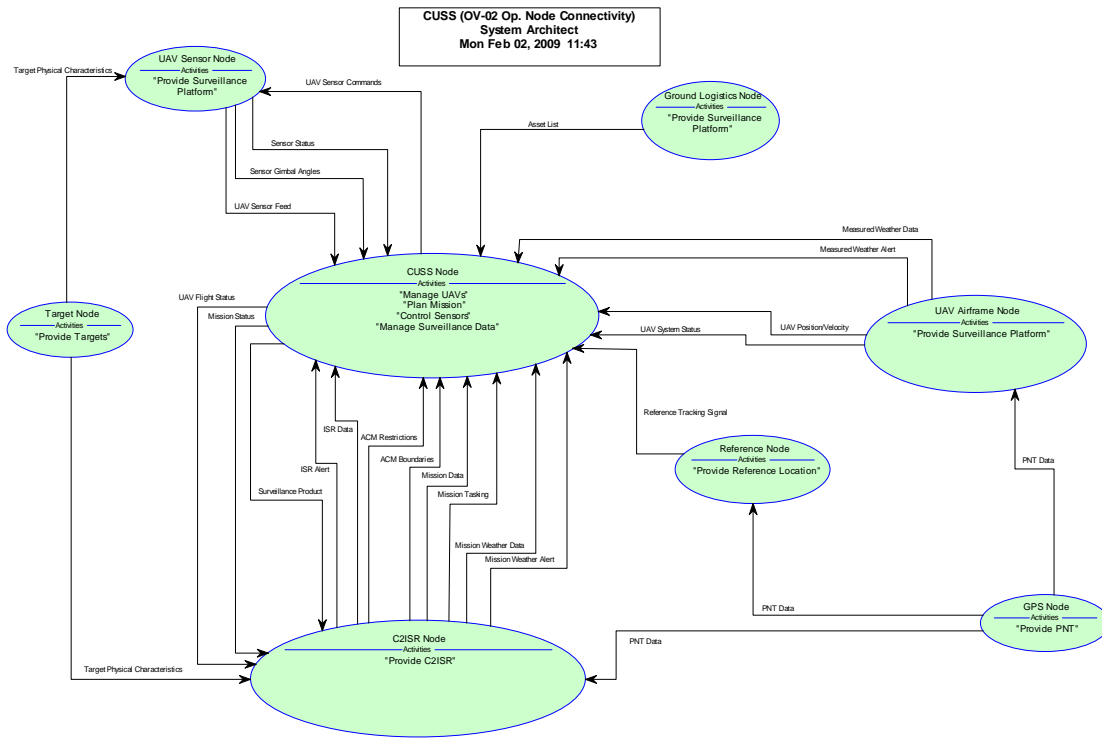
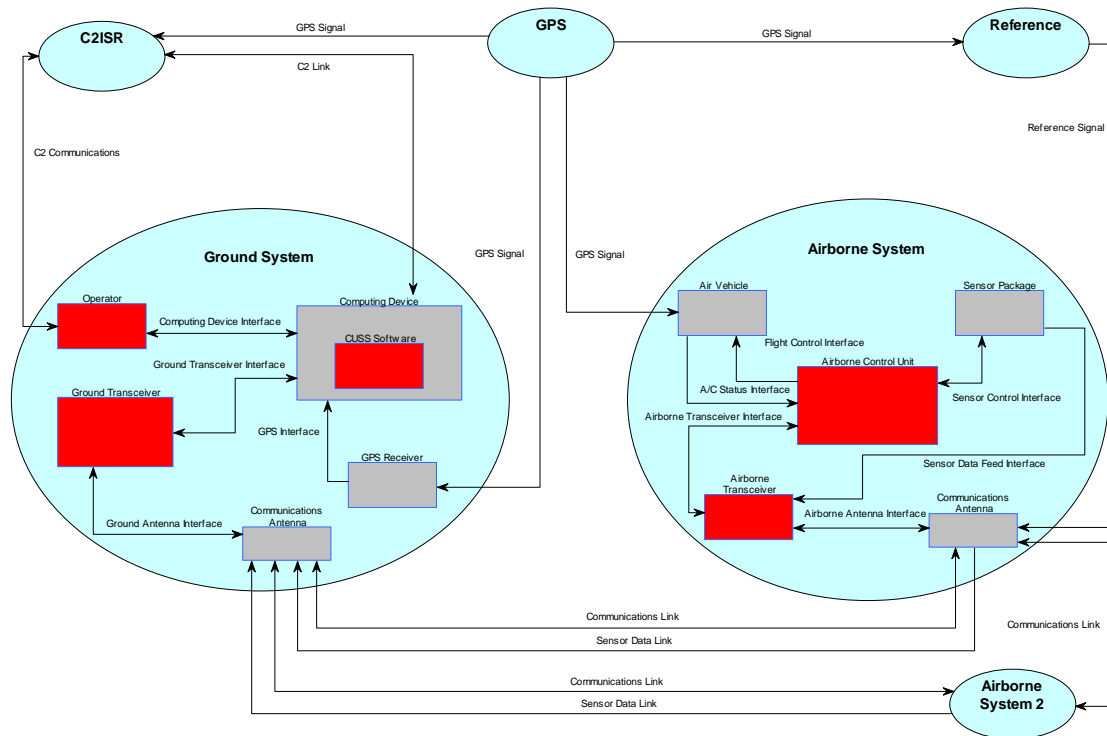

**Figure 29. CUSS OV-2 Operational Node Connectivity Description**

**SV-1.**

The *SV-1 Systems Interface* represents a physical implementation of the activities identified in the operational views. The conceptual CUSS is a combination of hardware and software components divided between the *Ground System Node* and the *Airborne System Node*, as depicted in Figure 30.





**Figure 30. CUSS SV-1 System Interface Description**

Within the CUSS *Ground System Node*, the primary CUSS components are the *Operator*, *CUSS Software*, and the *Ground Transceiver*. Components provided to the users that are not part of the CUSS developed components include the *Computing Device* that runs the CUSS software and serves as an interface between the *Operator* and software, a *GPS Receiver* antenna that provides home station location of the *Computing Device*, and a *Communications Antenna* that provides a *Communications Link* and *Sensor Data Link* capability between the *Ground System* and *Airborne System* platforms. Within the *Ground System*, the *Operator* has a two-way *C2 Communications* path between the *C2ISR Node* to receive mission tasking and relay mission status to higher command

authorities. The *Computing Device* also has a two-way *C2 Link* with the *C2ISR Node* to receive *Mission Planning* and *ISR Alert Data*. At any time, the *Operator* can use the *Computing Device* to interface with the CUSS components or any of the UAS assets under his or her direction. All outgoing data from the *Computing Device* is modulated by the *Ground Transceiver* before the *Communications Antenna* forwards data to the *Airborne System* platforms and sensors. Communications data coming from these platforms is also demodulated by the *Ground Transceiver* before being received by the *Computing Device*.

Within the *Airborne Systems Node*, only the *Airborne Control Unit*, or autopilot, and the *Airborne Transceiver* are CUSS provided components. Other system components that are provided to CUSS users and are not CUSS specific components include the *Air Vehicle*, *Sensor Package*, and *Communications Antenna* resident on the platform. The CUSS *Airborne Control Unit* is contained within the *Air Vehicle*. It is capable of providing flight control information to the platform and accepting health and status data from the platform. The *Air Vehicle* is responsible for receiving a *GPS Signal* and passing *PNT Data* to the *Airborne Control Unit*. Additionally, all sensor control and status information is routed through the *Airborne Control Unit*. Any data going from the *Airborne Control Unit* or *Sensor Package* back to the *Ground System* or relayed to another *Airborne System* is modulated by the *Airborne Transceiver* and sent through the *Communications Antenna* on the *Airborne System*. Similarly, data received by this antenna is routed through the *Airborne Transceiver* and de-modulated.

## SV-4.

After the SV-1 was completed, the team evaluated the architecture to identify system functions that are specific to CUSS developed components. For the CUSS *SV-4 Functional Decomposition* found in Figure 31, the team began with the *Ground Systems* and the *Airborne Systems Nodes* and identified each component within the respective node. The CUSS *Ground Node* contains the *Operator*, *Ground Transceiver*, and *CUSS Software*. The *Airborne Node* contains the *Airborne Control Unit* and the *Airborne Transceiver*.

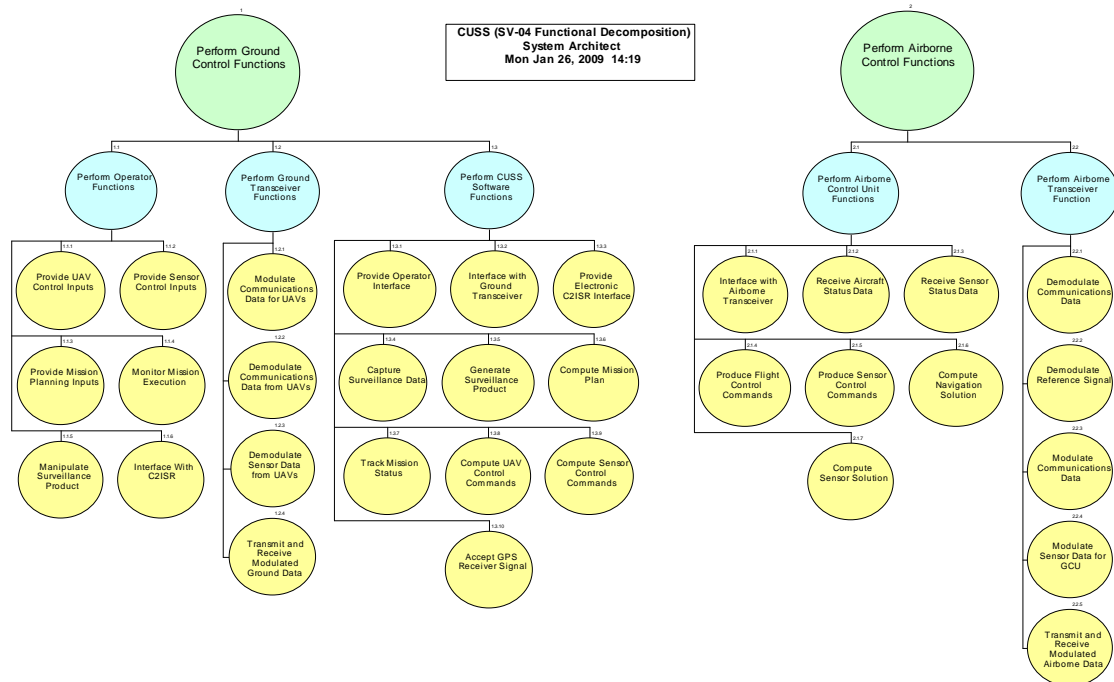

Figure 31. CUSS SV-4 System Functionality Description

This hierarchy was further decomposed by identifying the system functions, requirements, and information flows specific to each of these components. By tracing mission threads derived from the CONOPS, the team verified that each component provided the required functionality to execute a wide array of operational missions.

#### ***SV-5.***

After the *Systems Functionality Description* was finalized, the team created the final architecture product for the conceptual CUSS, the *SV-5 Operational Activity to System Function Traceability Matrix* in Table 1. This matrix takes the system functions identified in the SV-4 and maps them to the operational activities identified in the OV-5.

**Table 1. CUSS SV-5 Activity to Function Traceability Matrix**

SYSTEM FUNCTION			OPERATIONAL ACTIVITY																
			A1.1 Select Resources	A1.2 Set Constraints	A1.3 Set Mission Parameters	A1.4 Generate Mission Plan	A2.1 Conduct Mission	A2.2 Track Reference Point	A2.3 Manage Formation	A2.4 Navigate UAVs	A2.5 Generate Control Commands	A3.1 Manage Sensor	A3.2 Control Sensors	A3.3 Track Point Of Interest	A3.4 Generate Sensor Commands	A4.1 Process Data	A4.2 Record and Playback Data	A4.3 Interpret Data	A4.4 Produce Surveillance Product
1. Perform Ground Control Functions	1.1. Perform Operator Functions	1.1.1. Provide UAV Control Inputs																	
		1.1.2. Provide Sensor Control Inputs																	
		1.1.3. Provide Mission Planning Inputs	X	X	X														
		1.1.4. Monitor Mission Execution					X												
		1.1.5. Manipulate Surveillance Product																	
		1.1.6. Interface with CZSR	X	X	X		X												
	1.2. Perform Ground Transceiver Functions	1.2.1. Modulate Communications Data for UAVs							X	X	X	X			X	X			
		1.2.2. Demodulate Communications Data from UAVs					X	X	X				X	X			X		
		1.2.3. Demodulate Sensor Data from UAVs												X			X		
		1.2.4. Transmit and Receive Modulated Ground Data					X	X	X	X	X	X	X	X	X	X			
	1.3. Perform CUSS Software Functions	1.3.1. Provide Operator Interface	X	X	X	X	X	X	X	X	X	X	X	X	X	X	X	X	X
		1.3.2. Interface with Ground Transceiver					X	X	X	X	X	X	X	X	X	X			
		1.3.3. Provide Electronic CZSR Interface	X	X	X		X												
		1.3.4. Capture Surveillance Data															X	X	
		1.3.5. Generate Surveillance Product																	X
		1.3.6. Compute Mission Plan					X												
		1.3.7. Track Mission Status	X			X	X	X	X					X					
		1.3.8. Compute UAV Control Commands									X	X	X						
1.3.9. Compute Sensor Control Command													X	X	X				
1.3.10. Accept GPS Receiver Signal				X				X											
2. Perform Airborne Control Functions	2.1. Perform Airborne Control Unit Functions	2.1.1. Interface with Airborne Transceiver					X	X	X	X	X	X	X	X	X				
		2.1.2. Receive Aircraft Status Data					X		X	X	X			X			X		
		2.1.3. Receive Sensor Status Data												X		X	X		
		2.1.4. Produce Flight Control Commands										X							
		2.1.5. Produce Sensor Control Commands														X			
		2.1.6. Compute Navigation Solution										X							
		2.1.7. Compute Sensor Solution													X				
	2.2. Perform Airborne Transceiver Function	2.2.1. Demodulate Communications Data							X	X	X	X		X	X				
		2.2.2. Demodulate Reference Signal								X									
		2.2.3. Modulate Communications Data					X	X	X				X	X			X		
		2.2.4. Modulate Sensor Data for GCU													X			X	
		2.2.5. Transmit and Receive Modulated Airborne Data					X	X	X	X	X	X	X	X	X	X			

By comparing and evaluating each system function against the operational activities, the team showed that each operational activity was realized through system functions and each system function supported one or more operational activities. Evaluation of this matrix allowed the team to determine if any system components were being underutilized or overburdened during operational use. The *Provide Operator Interface* function performed by the *CUSS Software* is involved in every operational

activity. Also, the *Ground and Airborne Transceivers* are key to activities that involve communications between the *Ground and Airborne System Nodes*. Sufficient processing power and software stability will minimize the possibility of the interface being a system limitation. The transceivers must be designed with enough capacity to handle the amount of communications identified, as well as reliability and redundancy. Overall, the team believes system utilization across the architecture is balanced and appropriate for the required functions performed by the CUSS. Furthermore, the SV-5 shows that the envisioned physical implementation is feasible for achieving the necessary operational activities.

### **Test Architecture**

Upon completing the conceptual architecture and reviewing the actual flight test configuration, the team created a test architecture that accurately depicts the components and functionality of the prototype system. The test architecture products include a modified OV-1, OV-2, OV-5, and SV-1. The SV-4 and SV-5 remain unchanged from the conceptual architecture.

#### ***OV-1.***

The high level operation concept shown in Figure 32 depicts the operational scenario the team used to validate the conceptual architecture and demonstrate the feasibility of cooperative control with multiple UAVs. Within this scenario, the *Operator* was tasked to provide persistent surveillance of stationary vehicles using four BATCAM UAVs. Once the UAVs were airborne, the *Operator* provided command and control

inputs to the Kestrel™ Autopilot resident on each BATCAM using the Laptop interface, Virtual Cockpit™ software, and the Commbox from inside the Flight Test Trailer. The Kestrel™ autopilot also used this same communications path to return *Telemetry Data* to the *Operator*. *Sensor Feed* information was returned via a 2.4-2.5 GHz analog video link and displayed to the *Operator* on the Laptop screen in a Quad Video format.

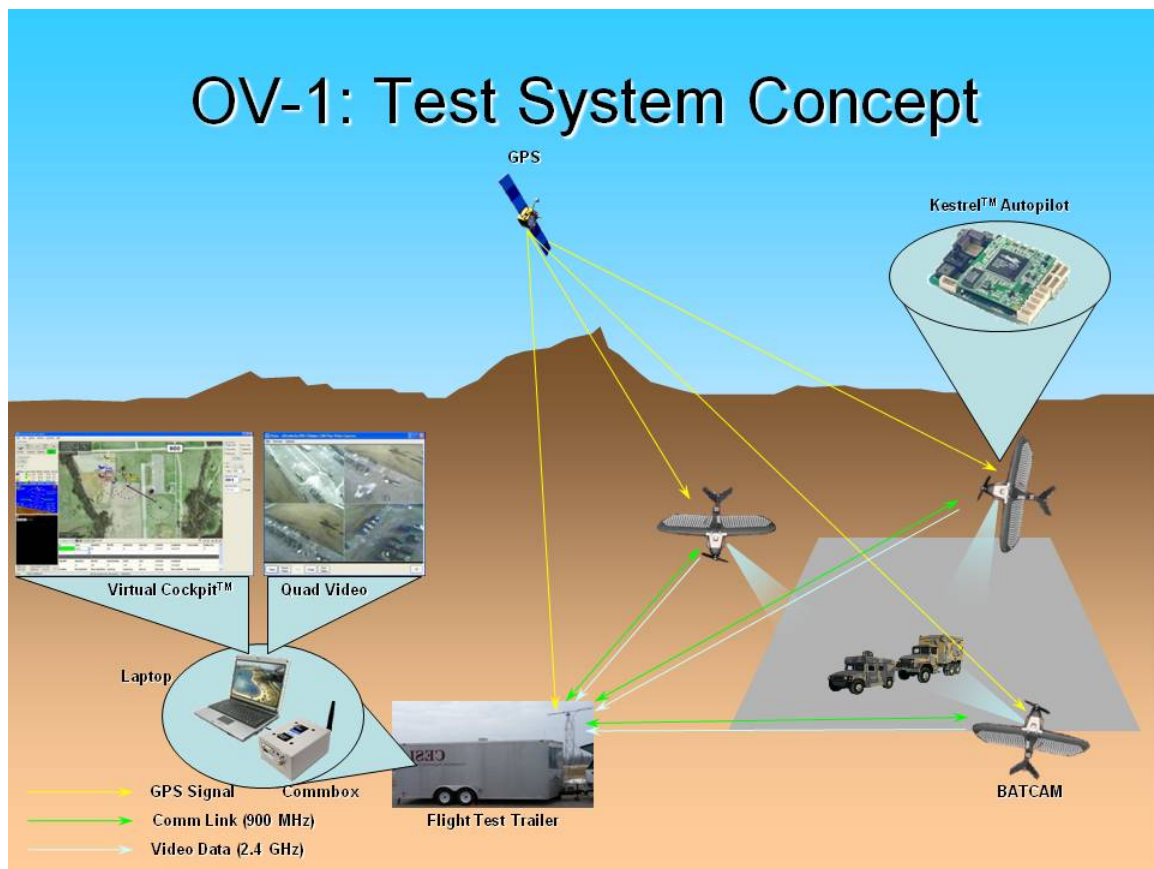

**Figure 32. Test OV-1 System Concept**

The OV-1 highlights some notable differences between the conceptual system and the test system. First, there are no communication links between the aircraft; they only communicate with the ground station. This means that the aircraft do not share data

directly or relay data from the ground station to each other. Also, there is no link to any external C2ISR entity.

#### **OV-2.**

The test OV-2, shown in Appendix L, shows minor differences from the Conceptual OV-2. The *C2ISR Node*, which would represent higher command in battlefield operations, is simulated by the test team. The *Reference Node* and *Reference Node Signal* is not depicted, since the aircraft were not equipped to receive a beacon signal. The Virtual Cockpit™ software does include the ability to direct aircraft based on the position of the ground station, in effect acting as a reference signal, but this capability was not implemented in any tests. Lastly, the *UAV Airframe Node* did not collect *Weather Data* or generate *Weather Alerts*, so the team eliminated *Measured Weather Data* and *Measured Weather Alerts* from the diagram.

#### **OV-5.**

The test OV-5, shown in Appendix M, also contains minor differences from the Conceptual OV-5. All operational activities were present in the test system, but most were not as robust as envisioned.

In the *External Systems Diagram*, Figure 33, as in the OV-2, the *Provide C2ISR* operational activity is simulated by the test team, the *Provide Reference Location* activity and all ICOMs going in and out of the activity are deleted, and the *Measured Weather Alert* and *Measured Weather Data* ICOMs are also omitted.



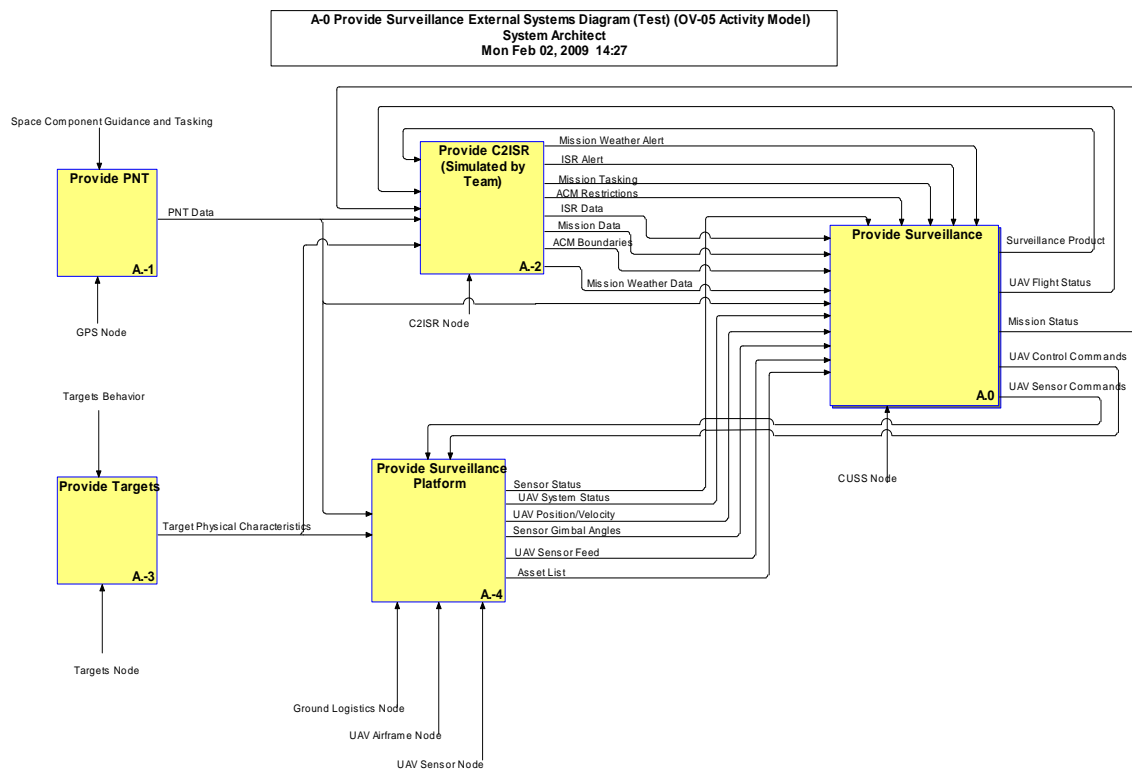

**Figure 33. Test OV-5 A-0 External Systems Diagram**

These changes flow to the *Context Diagram* and the *A0 Provide Surveillance Diagram*, Figure 69 and Figure 70 in Appendix M. Internal to the *A0 Provide Surveillance Diagram*, the team deleted the *Sensor Tracking Error* ICOM which leaves the *A3 Control Sensors* operational activity and enters the *A2 Manage UAVs* operational activity; the *UAV Orientation* and *UAV Position and Velocity* ICOMs which enter the *A3 Control Sensors* operational activity; and the *Target Location* ICOM exiting the *A4 Manage Surveillance Data* operational activity and entering the *A1 Plan Mission* and *A2*

*Manage UAVs* operational activities. The test system could not automatically track a target with its sensors or generate target location data from its sensors.

All of these changes flow to the A0 level diagrams. There are no changes internal to any of the A1 level child diagrams, as all functionality of these diagrams is realized by the test-bed system.

### ***SV-1.***

The most significant differences between the conceptual and test architectures can be discerned from the two versions of the SV-1. The conceptual SV-1, shown in Appendix H, shows a more abstract view of the system, providing a general description of system components that need to be implemented. The test SV-1, shown in Figure 34, shows the specific components used in the test bed system. Ideally, if the conceptual system was implemented, the components in the test bed system would be combined and integrated into the components identified in the conceptual architecture.

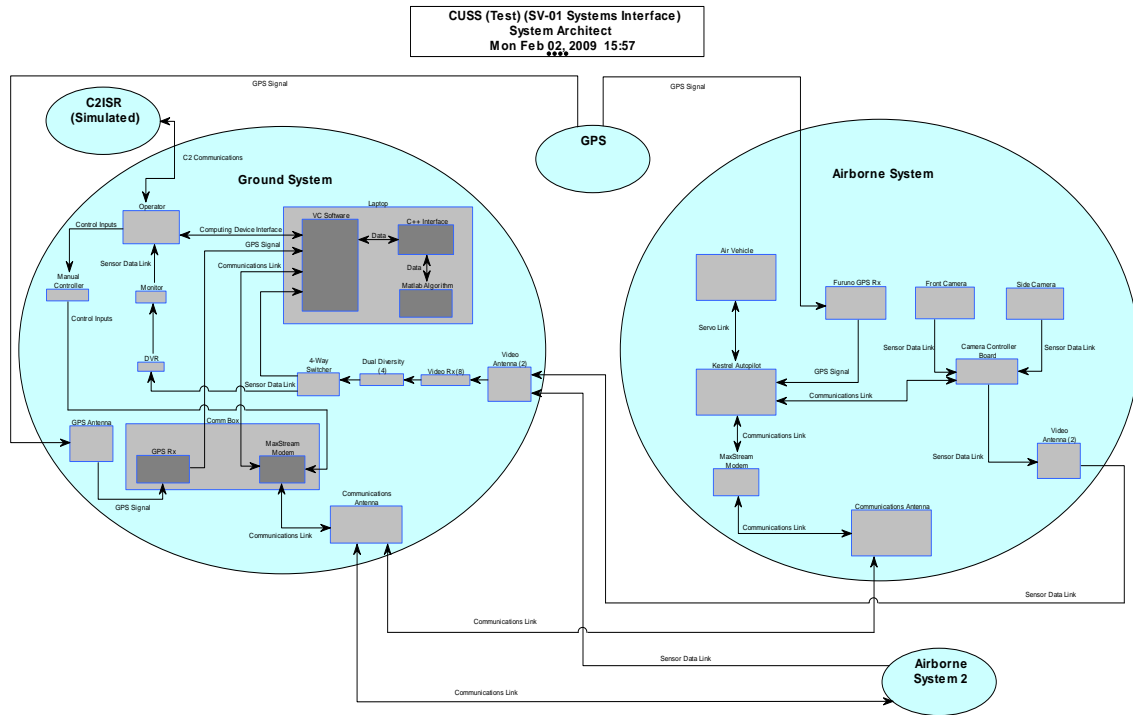

**Figure 34. Test SV-1 System Interface Description**

To show the correlation between the two diagrams, the team developed a component mapping matrix, shown in Table 2 that shows which actual test components were used to accomplish the functions of the conceptual system components.

**Table 2. Test to Conceptual Component Mapping Matrix**

		Conceptual CUSS System Components											
		Ground System						Airborne System					
		Operator	Computing Device	CUSS Software	Ground Transceiver	GPS Receiver	Communications Antenna (Ground System)	Air Vehicle	Airborne Control Unit	Sensor Package	Airborne Transceiver	Communications Antenna (Airborne Mode)	
<b>Test System Components</b>	Operator	X											
	Laptop		X										
	Monitor		X										
	Manual R/C Controller		X										
	VC Software			X									
	C++ Interface			X									
	Matlab Algorithm			X									
	4-Way Switcher			X									
	DVR			X									
	Maxstream Modem in Commbx				X								
	Power Divider (2)				X								
	Video RX (8)				X								
	Oracle Dual Diversity (4)				X								
	AverMedia Video Capture Device				X								
	GPS Antenna					X							
	GPS Receiver					X							
	Video Antenna (2)						X						
	Communications Antenna (Ground System)						X						
	<b>Airborne System</b>	BATCAM Airframe						X					
		Furuno GPS RX						X					
Kestrel Autopilot								X					
Front Camera									X				
Side Camera									X				
Camera Controller Board									X				
Maxstream Modem (Airborne System)										X			
Communications Antenna (Airborne System)											X		
Video Antenna												X	

Based on this component mapping, the team decided that the test system components effectively produced the functions of the conceptual system components. Therefore, the *SV-4 System Functionality Description* and *SV-5 Operational Activity to*

*System Function Traceability Matrix* for the conceptual architecture applied to the test architecture as well.

## **Flight Testing**

### ***Autopilot Tuning.***

#### *Tuning Flights.*

The first step in making the test system viable for performing algorithm testing was to tune the Kestrel™ autopilot to the BATCAM airframe. Within its nonvolatile memory, the autopilot houses a set of Proportional/Integral/Derivative (PID) feedback gains and a set of miscellaneous parameters known as Flash values. The PID values govern the behavior of the autopilot control loops, while the Flash values specify a large variety of settings such as servo limits, modem settings, waypoint tracking parameters, loiter orbit direction, and trim pitch and airspeed values. The team started with a baseline set of PID and Flash values generated from BATCAM preloaded software and recommended defaults from Procerus. For tuning, the team used published procedures from Procerus to tune the control loops and adjust the other flight parameters.

Contrary to team expectations, the tuning process took two and one half days of testing and forty-three flights to satisfactorily tune all four aircraft. A number of issues contributed to the length of this process. First, it took several attempted launches to discover that the V-tail control surfaces moved the aircraft in an unexpected manner. Instead of controlling the aircraft like ailerons to produce roll, V-tail surfaces act to yaw the aircraft. This yawing motion induces a roll in the direction of the yaw.

Next, the team discovered that the aircraft was nearly uncontrollable in the yaw and roll axes when flown manually by the RC operator due to aircraft instability. Although the tuning procedures specified to start with all autopilot control loops disabled, after several short attempts at stable flight, the team decided to enable the rate loops. The yaw, roll, and pitch rate loops produce control commands to counter sensed rates around the corresponding axes. The preloaded BATCAM PID values for these loops were sufficient to fly the aircraft manually with rate loop assistance.

Many of the remaining default PID values, however, were not adequate to allow the aircraft to achieve and maintain the desired altitude. The majority of the remaining tuning tests were spent refining pitch and throttle control loops to tighten altitude control. This process was exacerbated by the BATCAM's susceptibility to winds, which was due to its small size, and its relatively short flight times, which were typically between 15 and 20 minutes.

#### *System Impact.*

This tuning process is not trivial to the implementation of a common control system for use in multiple types of UAVs. Before a system like the CUSS can be installed on a particular airframe, it must be thoroughly tuned to properly control that platform. Ideally, this should be performed by a testing team responsible for integration efforts. Then those settings should be fixed to a standard, distributed to UAVs in the field, and updated through a formal process as required. Manpower, facility, airspace, and cost requirements will be impacted by this process.

With a common platform, the majority of the tuning parameters can be standardized across each aircraft. However, the team found that individual BATCAMs

required control surface trim and autopilot sensor calibration settings that were specific to each individual aircraft. Consequently, this issue will likely become a future field maintenance requirement for operational users. After setting these values for each UAV, operators will also need to periodically update them as sensors drift and aircraft aerodynamics change from normal wear and tear during operational use.

### ***BATCAM Performance.***

The team used the flight tests to measure the performance of the BATCAM UAVs, focusing on parameters that affect mission planning, formation management, and sensor placement. Data was captured from personal observations as well as the data logger built into Virtual Cockpit™, which stores telemetry in MATLAB® files.

### ***Airspeed.***

The aircraft was trimmed at half throttle, which produced a trim airspeed of 20 knots (kts). This was used as a baseline for all flight plans. The maximum and stall speeds were not specifically tested; however, the maximum recorded speed after autopilot tuning was 44 kts in a dive and the minimum recorded was 5 kts during a landing approach.

### ***Endurance.***

Flight time was limited by the battery and affected by several factors such as temperature, average airspeed, and altitude changes. Nearly all tests were conducted with a 1320 milliampere-hour (mAh) Lithium Polymer (LiPo) battery. The length of a ground test run at full motor power was 11 minutes (min). The typical duration of flight test sorties terminated due to low battery voltage was around 20 min. The longest sortie with this battery was measured at 28 min.

The BATCAM kits also came with several larger 2100 mAh LiPo batteries. The team test flew these batteries and confirmed the same trim values and PID settings could be used for both sizes of batteries. The team also performed an endurance test flight with a 2100 mAh battery. The flight length was 44 min, a 57% improvement over the longest small battery flight, and in accordance with the 59% increase in available energy capacity.

#### *Turn Time.*

Although the minimum time required between sorties, “turn time,” is a function of the aircraft, it is also dependent on the control system. Maintenance on the BATCAM between sorties was minimal, consisting only of changing the battery and inspecting the exterior for damage. The control system required time to reacquire a GPS lock and fix the aircraft’s position. The operator had to zero the static pressure reading, which changed from flight to flight, and perform a check of the pitot system to ensure proper airspeed and altitude readings. The operator also had to upload the flight plan to the autopilot through Virtual Cockpit™.

The team conducted a turn time test in conjunction with a persistent surveillance scenario on 9 Feb 2009. The objective of the test was to establish and maintain two aircraft on station over a target while conducting five total flights. Three aircraft were used in the test, requiring two aircraft turns. The aircraft were launched every five minutes. Once the third aircraft had been launched and established on station, the first was recovered and turned. The same recovery and turn took place for the second aircraft launched. A timeline of the test is shown in Figure 35.



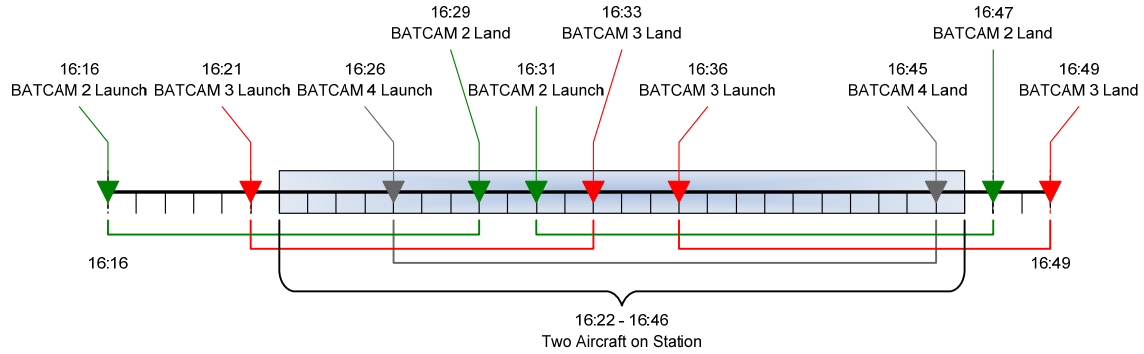

**Figure 35. Persistent Surveillance and Turn Test Timeline**

The aircraft turns were measured from the time the aircraft touched the ground on landing until the aircraft was ready to be placed into takeoff mode for launch again. The first turn was measured at 1 min 43 seconds (s), and the second at 1 min 20 s. The aircraft were ready to re-launch at the five minute interval. This procedure could have been performed continuously, resulting in an indefinite persistent surveillance of the target.

*Altitude.*

The ability of the aircraft to hold the desired altitude was measured by comparing the measured altitude to the commanded altitude in the telemetry data. This comparison was only made after the aircraft had reached the commanded altitude, and for as long as the commanded altitude remained constant. This eliminated errors while the aircraft was in transition. It is important to note that this characterization does not account for errors in the aircraft's altitude sensing system, which is based on static pressure. It is in essence a performance measurement of the altitude control loops in the autopilot.

Figure 36 shows an example commanded and measured altitude profile during one of the test flights. The bands at the bottom of the figure represent the areas where the data points met the above criteria for inclusion in the performance measurement.

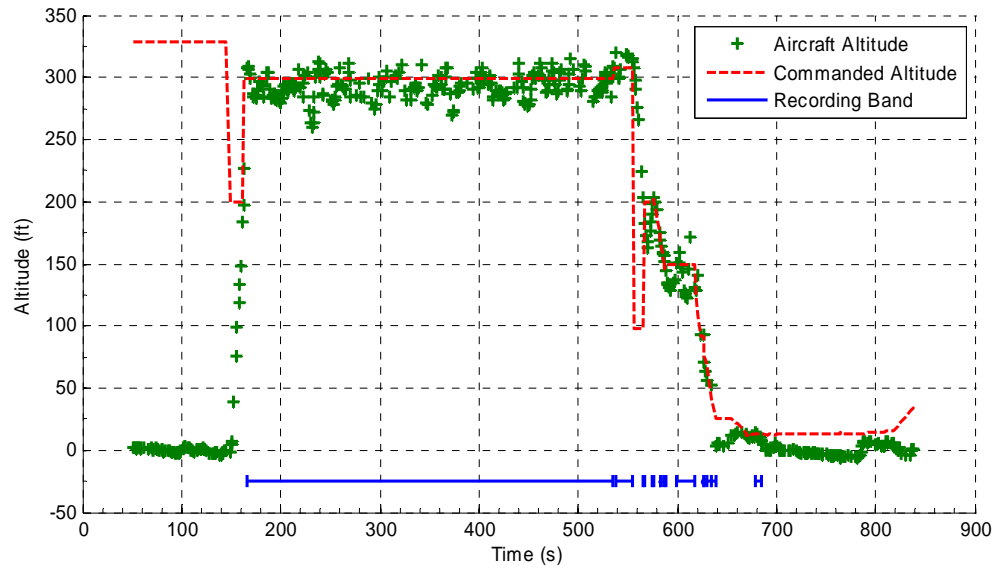

**Figure 36. Example Altitude Profile**

This analysis was performed on a test flight in which all four BATCAMs were flown. All vehicles had the exact same PID values for all control loops; the only differences in settings were aircraft servo trim and sensor calibration values. Figure 37 shows the altitude profiles for the four aircraft over the course of the test on 13 Nov 2008.

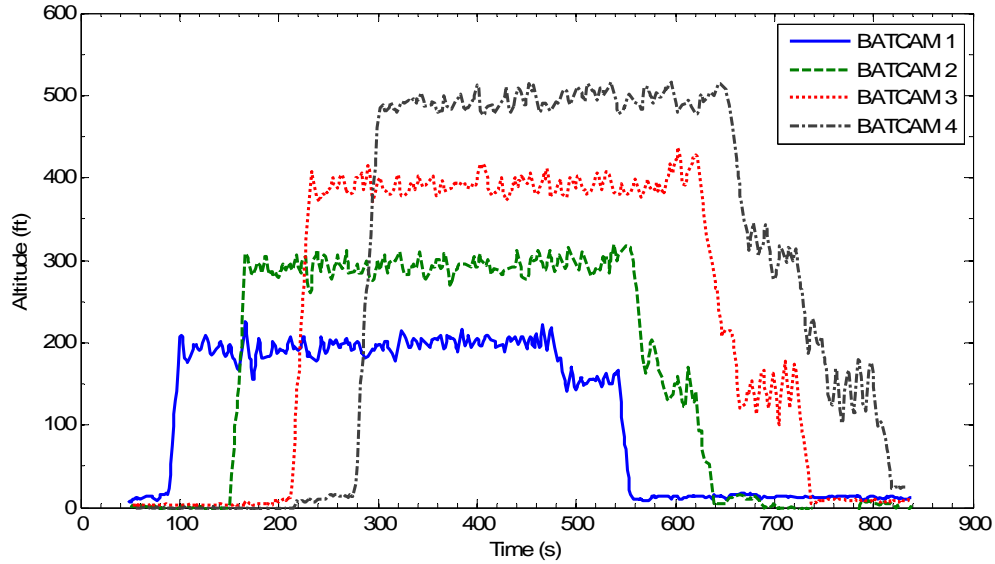

**Figure 37. 4-Ship Altitude Profile**

Figure 38 shows the deviations between the measured and commanded altitudes for the observed segments of the above profiles. A positive deviation means that the

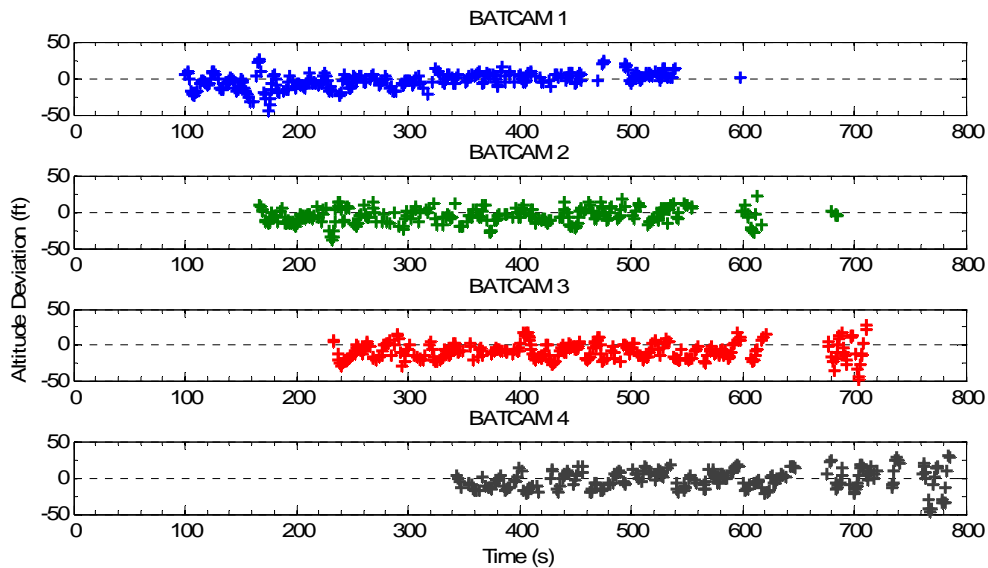

**Figure 38. Altitude Deviations**

aircraft was above the commanded altitude, and vice-versa. The largest deviations generally occurred at the end of the sortie, as the aircraft transitioned to their pre-landing orbits.

Table 3 lists the maximum high and low, mean, and root mean square (RMS) deviations for each aircraft and all test points combined. The RMS deviation is a measurement of how far off assigned altitude (high or low) the aircraft was on average. The bias towards low altitude shown in Table 3 suggests that the trim angle-of-attack was set too low.

**Table 3. Altitude Deviation Statistics**

Aircraft	Max High (ft)	Max Low (ft)	Mean (ft)	RMS (ft)
1	26.2	-45.4	-3.1	11.1
2	21.3	-38.3	-5.5	11.5
3	28.4	-49.2	-8.7	14.4
4	30.1	-47.0	-2.0	14.0
All	30.1	-49.2	-4.9	12.8

Figure 39 is a histogram of altitude deviations at each of the measurement points for all four aircraft, divided into 50 bins. The data appears to be normally distributed. A best fit normal distribution was generated using parameters from the MATLAB® “normfit” function. “Normfit” provides estimates of the mean ( $\mu$ ) and standard deviation ( $\sigma$ ) for the given data. The probability density function for a normal distribution is

defined in Equation 1. The best fit normal distribution is overlaid on the histogram data in Figure 39 with vertical lines noting  $\mu$ ,  $\mu \pm \sigma$ , and  $\mu \pm 2\sigma$ .

$$y = f(x|\mu, \sigma) = \frac{1}{\sigma\sqrt{2\pi}} e^{-\frac{(x-\mu)^2}{2\sigma^2}} \quad (1)$$

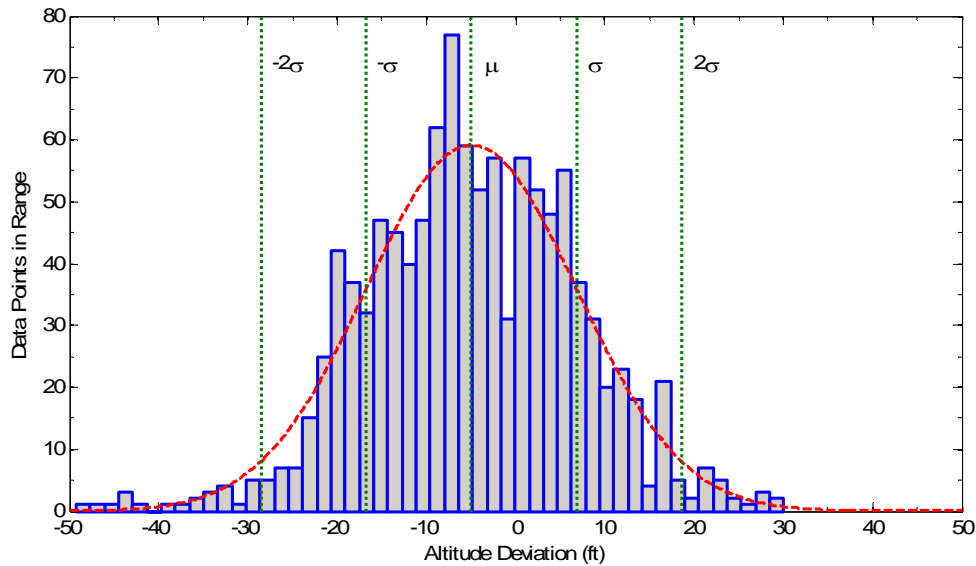

**Figure 39. Altitude Deviation Histogram**

Figure 40 shows a cumulative distribution function (CDF) for the altitude deviation data overlaid on the best fit normal distribution CDF. The close fit is further evidence of a normal distribution. If this assumption is valid, the aircraft can be expected to remain within +19 to -29 ft of assigned altitude 95% of the time (within  $2\sigma$ ).

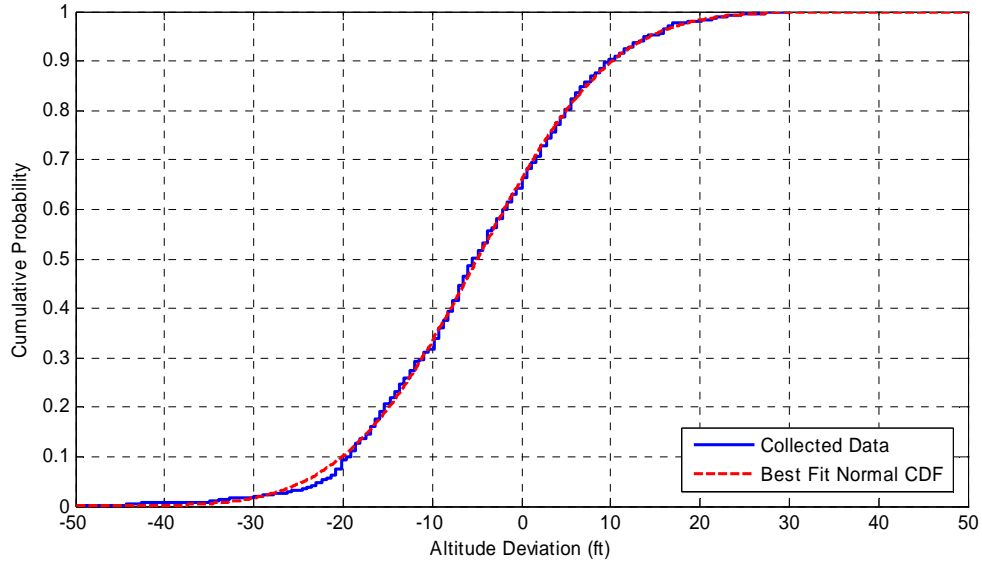
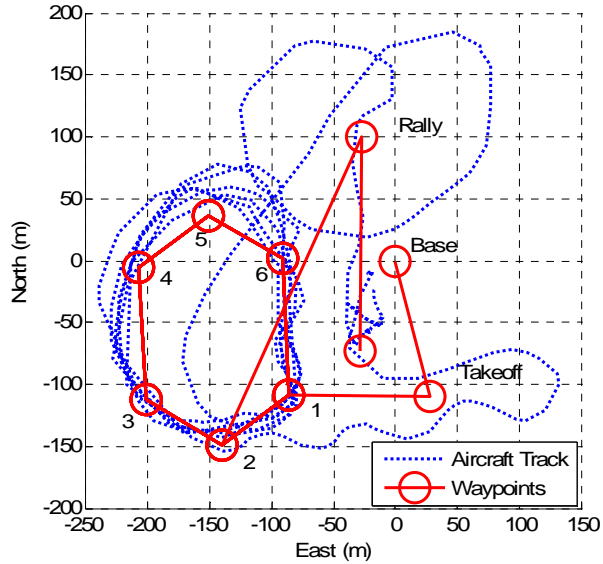

**Figure 40. Altitude Deviation Cumulative Distribution Function**

*Waypoint Navigation.*

BATCAM navigation performance was measured in much the same manner as altitude performance. For navigation between waypoints the aircraft position was compared to a straight line course between the two navigation points. The measurements were taken when the aircraft was in waypoint navigation mode and was established on the navigation leg. Again, this does not account for errors in the sensed position of the aircraft from the GPS; it only measures autopilot control loop performance.

Figure 41 shows an example of aircraft position and the commanded waypoints during the flight. The set of waypoints that forms the hexagonal shape (1-6) were where the aircraft was in waypoint navigation mode. This is opposed to waypoints such as the “Rally” point which commanded a loiter orbit.



**Figure 41. Example Navigation Ground Track and Waypoints**

The analysis was performed on the same test flight as the altitude characterization, where all four aircraft were flown. The winds during this flight test were from the south at 10 to 12 kts. The winds caused the aircraft to be blown off course to the north, as seen in Figure 41. Deviation was defined as the perpendicular distance between the line between the two waypoints and the aircraft's position, where positive refers to the aircraft being right of course. This is shown in Figure 42 which depicts a negative deviation.

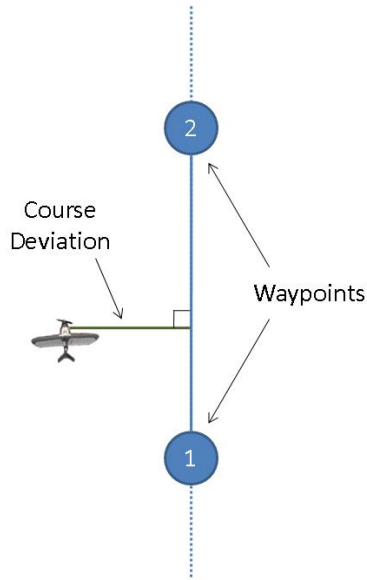

**Figure 42. Course Deviation Definition**

The course deviations for all four aircraft are shown in Figure 43. The largest deviations typically occurred when the aircraft were turning on the two legs from downwind to upwind (between waypoints 4, 5, and 6 in Figure 41).

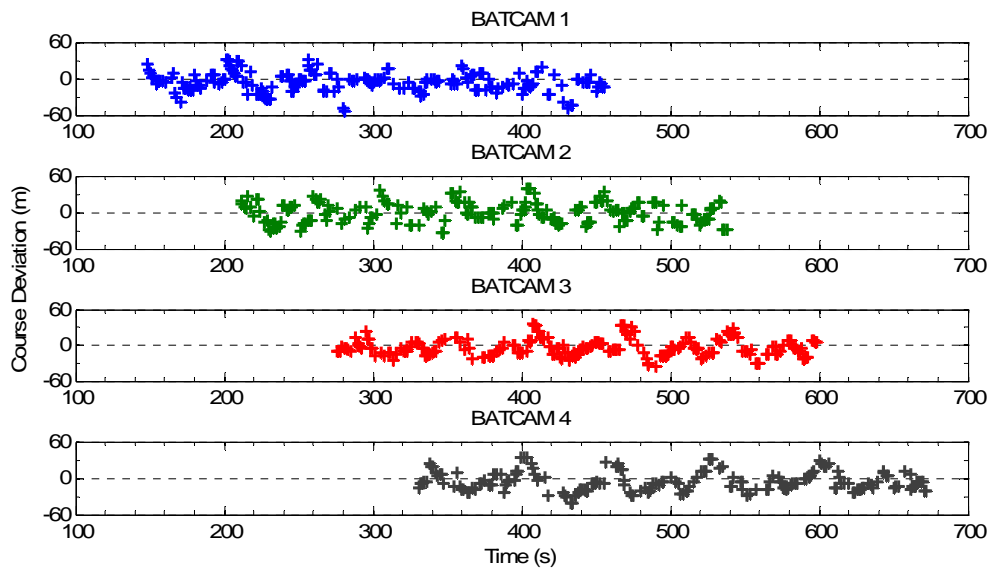

**Figure 43. Course Deviations**

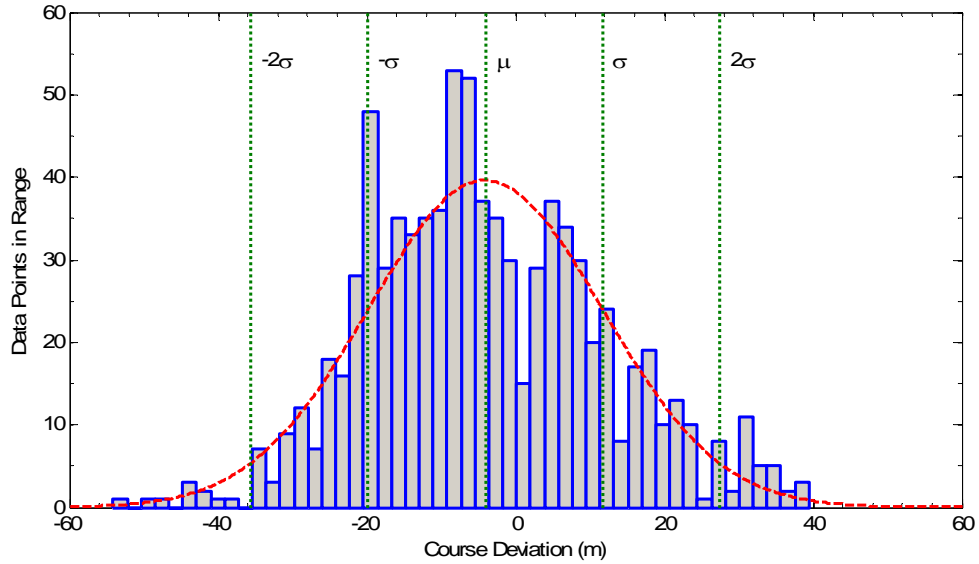

Table 4 lists the maximum right (positive) and left (negative), mean, and RMS deviations for each aircraft and all test points combined. The bias towards left of course shown in Table 4 is due to a combination of the winds with the clockwise direction of the series of waypoints.

**Table 4. Course Deviation Statistics**

Aircraft	Max Right (m)	Max Left (m)	Mean (m)	RMS (m)
1	31.3	-54.1	-6.4	16.9
2	39.4	-34.5	-0.6	16.7
3	36.1	-35.1	-3.9	14.7
4	34.9	-42.3	-5.4	16.7
All	39.4	-54.1	-4.1	16.3

Figure 44 is a histogram of course deviation at each of the measurement points for all four aircraft, divided into 50 bins. Again, the data appears to be normally distributed. A best fit normal distribution is overlaid on the data in Figure 44 with vertical lines noting  $\mu$ ,  $\mu \pm \sigma$ , and  $\mu \pm 2\sigma$ .



**Figure 44. Course Deviation Histogram**

Figure 45 shows the altitude deviation data CDF overlaid on the best fit normal distribution CDF. Again, the close fit is further evidence of a normal distribution. If this

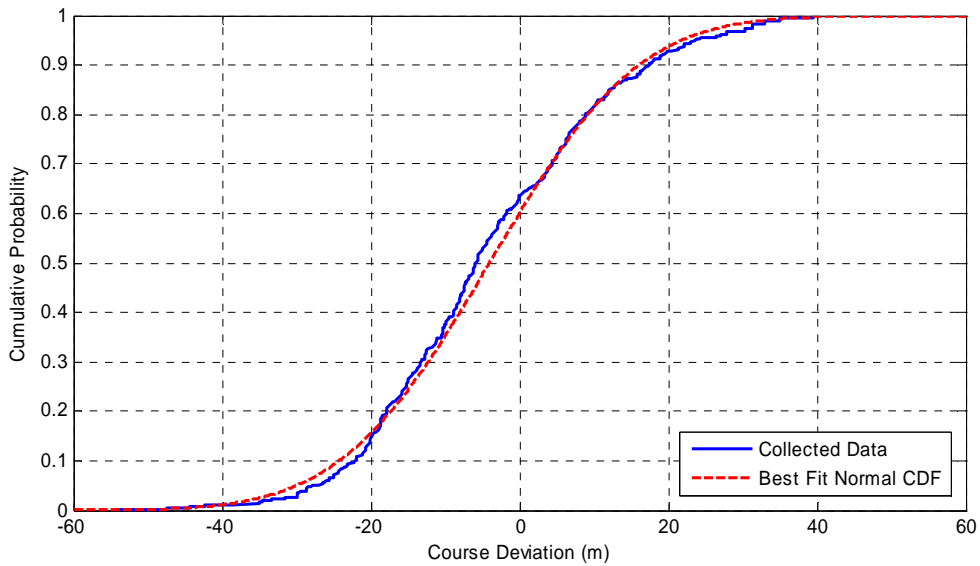
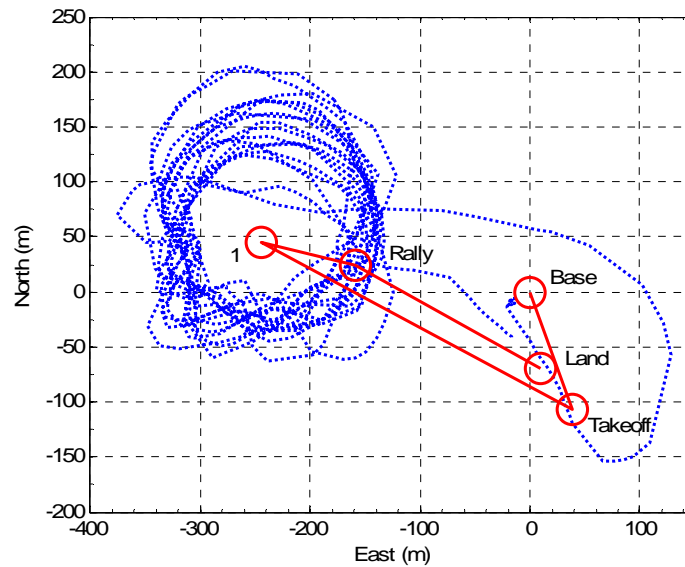

**Figure 45. Course Deviation Cumulative Distribution Function**

assumption is valid, the aircraft can be expected to remain within +27 to -36 m of assigned course 95% of the time (within  $2\sigma$ ). The numbers are only valid in similar wind conditions with the aircraft flying right-hand turns.

*Loiter.*

The other type of waypoint navigation for the Kestrel™ autopilot is a loiter mode where the aircraft orbits the selected waypoint at a specified radius. To measure performance in loiter mode, the aircraft radial distance from the waypoint was compared to the specified orbit radius. The measurements were taken from when the aircraft was commanded to loiter mode and had closed to the desired orbit radius until another mode was selected. Once again, these measurements do not take GPS errors into account. The circular path around waypoint 1 shown in Figure 46 is an example of an aircraft orbit track.



**Figure 46. Example Orbit Ground Track and Waypoints**

The analysis was performed on a flight test on 9 Feb 2009 in which all four aircraft were flown primarily in counter-clockwise loiter orbits. The specified orbit radius was 75 m. The winds on this test were out of the southeast varying from 7 to 14 kts. The aircraft were blown to the northwest of the orbit point, as seen in Figure 46. Orbit deviations were defined as the difference between the aircraft distance from the waypoint and the commanded orbit radius, where positive refers to the aircraft being outside the desired radius. This is shown in Figure 47 which depicts a positive deviation.

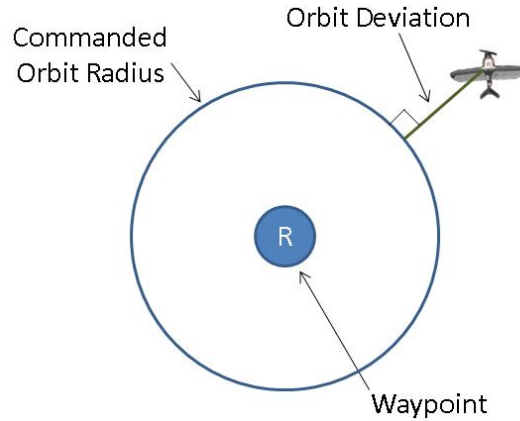

**Figure 47. Orbit Deviation Definition**

The orbit deviations for all four aircraft are shown in Figure 48. The greatest deviations occurred when the aircraft were turning from downwind to upwind, similar to the results of the course deviation test.

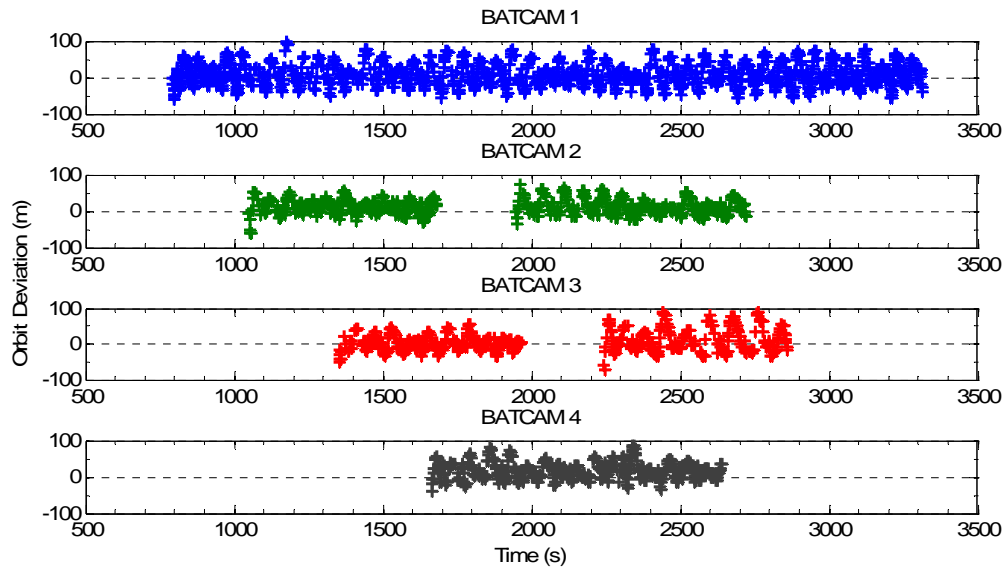

**Figure 48. Orbit Deviations**

Table 5 lists the maximum outside (positive) and inside (negative), mean, and RMS deviations for each aircraft and all test points combined. The system is biased towards flying outside the orbit.

**Table 5. Orbit Deviation Statistics**

Aircraft	Max Outside (m)	Max Inside (m)	Mean (m)	RMS (m)
1	97.8	-61.4	8.7	31.9
2	71.9	-60.7	12.0	23.1
3	89.9	-72.1	6.3	28.4
4	85.0	-39.0	18.6	29.6
All	97.8	-72.1	10.7	29.0

Figure 49 shows a histogram of orbit deviation data from all four aircraft, split into 50 bins. Because there is a limit to the deviation inside the orbit (the commanded orbit radius, or -75 m), a normal distribution would not fit the data. A best fit gamma distribution was generated using parameters from the MATLAB® “gamfit” function. “Gamfit” provides estimates of the gamma distribution parameters “a” and “b” for the given data. The probability density function for a Gamma Distribution is defined in Equation 2 where  $\Gamma$  is the Gamma function. Figure 49 shows a best fit gamma distribution overlaid on the histogram as well as the distribution mean ( $\mu$ ).

$$y = f(x|a, b) = \frac{1}{b^a \Gamma(a)} x^{a-1} e^{-\frac{x}{b}} \quad (2)$$

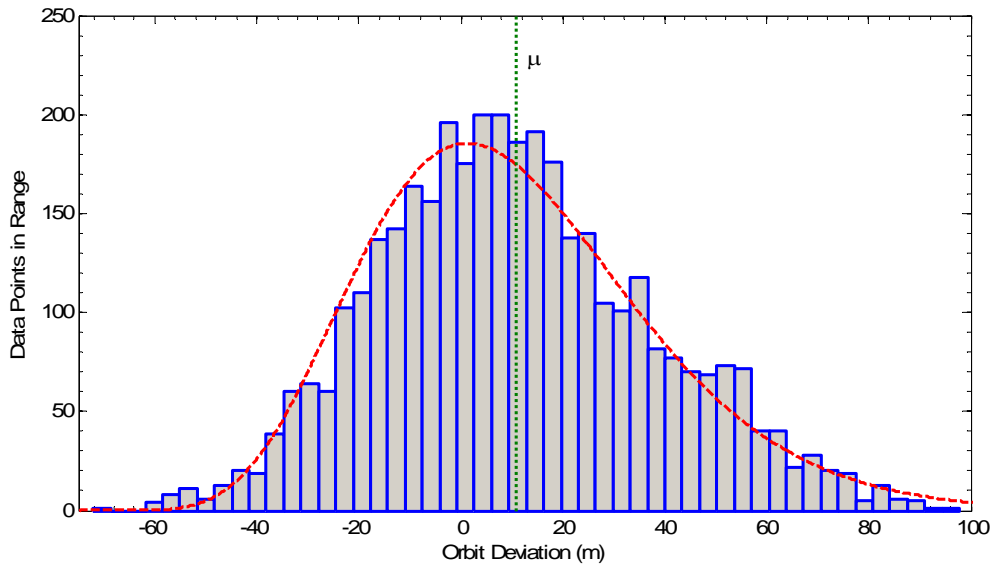

**Figure 49. Orbit Deviation Histogram**

Figure 50 shows the orbit deviation data CDF overlaid on the best fit gamma distribution CDF. If the distribution is valid, the aircraft can be expected to fly no more than 62 m outside the orbit radius 95% of the time. This is only valid in similar wind conditions and for a 75 m orbit radius.

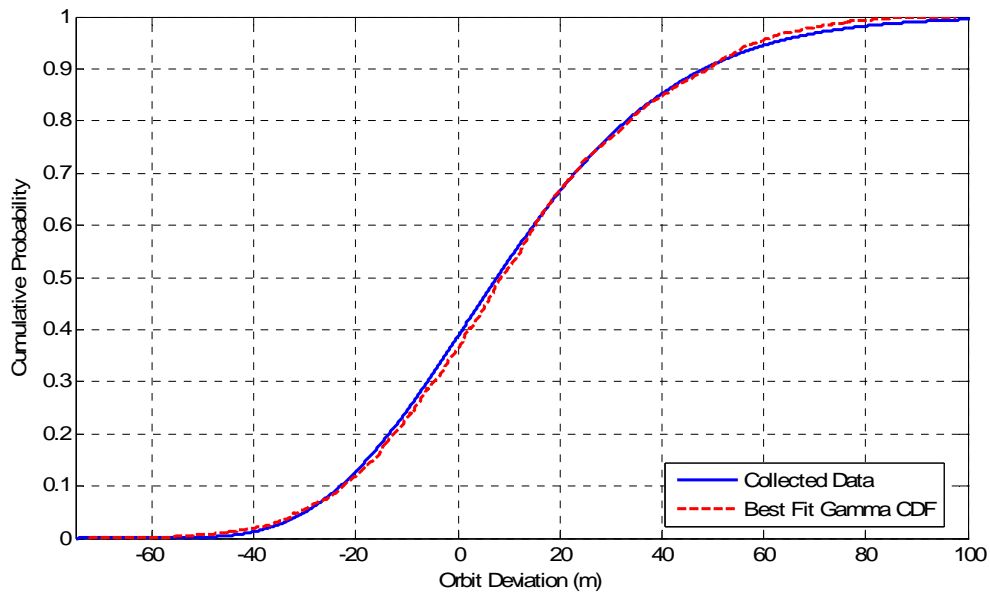

**Figure 50. Orbit Deviation Cumulative Distribution Function**

This result is considerably large and differs significantly from the aircraft performance in waypoint navigation. The tests were performed on different dates with different wind conditions. More significantly, the autopilot uses different control loops for waypoint and loiter navigation. It is possible to adjust the loiter navigation flash parameters without affecting waypoint navigation. Though loiter navigation values were adjusted during the autopilot tuning process, further experimentation with these

parameters may yield better results. This result does demonstrate the BATCAM's susceptibility to even light wind conditions, i.e., less than 15 kts.

#### *System Impact.*

The types of parameters examined above and the methods used to characterize them are important in implementing a common cooperative control system. For example, airspeed limitations affect to what degree airspeed commands can be used to adjust the formation position of a UAV, or whether it can keep up with a moving target. It also drives timing calculations during mission planning. Aircraft endurance affects mission planning calculations of mission range and on-station time. This, in turn, dictates the number of aircraft and sorties required to accomplish a mission. Aircraft turn time affects the ability to achieve persistent surveillance by generating a continuous stream of sorties. Altitude and navigation deviations impact formation considerations such as safe separation for deconfliction purposes. Altitude performance can also impact whether a system is allowed to fly in civilian airspace based on maintaining regulated tolerances. Navigation performance is also important in ensuring UAV sensors can be successfully placed on target, particularly in the case of fixed sensors.

If the system is to be scalable to a number of different UAV airframes, each aircraft type will need to be characterized and its parameters captured in a dataset. Mission planning, formation management, and navigation algorithms will need to utilize those parameter datasets in their calculations, potentially multiple sets if multiple aircraft types are used simultaneously.



### *Communications Performance.*

The team was able to measure one aspect of communications performance during the flight tests. The data logger in Virtual Cockpit™ captures telemetry packets generated by the Kestrel™ autopilots. The telemetry packets include a time stamp in milliseconds (ms), which allowed the team to measure the rate of packets.

#### *Multiple Aircraft.*

The default setting on the Kestrel™ autopilot broadcasts telemetry packets continuously with no deconfliction. When the team initially attempted to run multiple autopilots simultaneously, a significant drop in packet rate was observed for each agent added. Additionally, within Virtual Cockpit™ is a warning and failsafe setting that triggers the aircraft to return to the Rally point if no telemetry is received within a user defined period of time (6 seconds for the test flights conducted). This warning and failsafe triggered several times in ground testing with three or more aircraft, and once during a flight with just two aircraft. This drop in communications performance was due to the fact that the telemetry transmissions were not deconflicted. If a packet arrived at the Commbot while another was being received, then a packet collision occurred and both sets of data were lost.

To mitigate this problem, the team switched the communications scheme in Virtual Cockpit™ and on the Kestrel™ autopilot to a polling structure. This caused the autopilot to only transmit a telemetry packet when polled by the ground station. The ground station, in turn, polled the agents in sequence. It maintained a minimum time of 100 milliseconds (ms) between each poll and waited a maximum of 300 ms for a reply

before polling the next agent. If a telemetry packet was received after the 300 ms wait time, the receiver was still able to process it as long as a packet collision did not occur.

This packet polling scheme resulted in overall slower telemetry rates than non-polling, but had the advantage of reduced packet collisions. Table 6 shows a comparison of polling and non-polling telemetry data rates in packets per second (PPS) and the maximum observed time between packets received for a ground test with four aircraft. Though packet collisions do not appear to occur often in non-polling, when several do occur, the result can be the activation of the loss-of-communication failsafe. For the team, this reduced risk afforded by the polling structure outweighed the faster telemetry rates.

**Table 6. Polling and Non-Polling Telemetry Comparison**

Aircraft	Non-Polling Data Rate (PPS)	Polling Data Rate (PPS)	Non-Polling Max Packet Delay (s)	Polling Max Packet Delay (s)
1	1.6	1.1	4.9	3.9
2	1.3	1.0	4.1	3.9
3	1.6	1.1	3.1	3.5
4	1.6	1.0	3.1	3.3
All	1.5	1.0	4.9	3.9

*High Ground Control Command Rates.*

The team observed a related communications problem when testing Capt Booth's cooperative control algorithm [34]. His program generated flight paths of equal lengths for multiple aircraft to fly with the goal of having them arrive in an orbit simultaneously.

To further refine arrival times and then keep the UAVs equidistant within the orbit, his algorithm generated airspeed commands for each aircraft. These commands were initially sent at a rate of one per second for each aircraft.

In flight testing, as soon as the algorithm started sending these commands to the aircraft, the team observed a noticeable drop in telemetry rate. Also, part of the flight test procedures had the operator request each aircraft to download its waypoints to Virtual Cockpit™. This process was noticeably slower with the algorithm operating. Both effects were exaggerated when the team changed from testing the algorithm with two aircraft to three. Between flight tests of three aircraft, Capt Booth changed the algorithm to command airspeeds every two seconds per aircraft. This reduced the telemetry and waypoint download lag times. It is not clear if the communications lag is due to packet collisions or a reduced polling rate, but the constant stream of commands to the aircraft has the same effect as adding more agents to the system.

The team observed one other communications phenomenon when testing Mr. Smith's collision avoidance algorithm [36]. His program monitored telemetry data from aircraft until a potential collision threshold was crossed. Then, the program generated pitch, turn rate, and airspeed commands to the aircraft at the rate of the received telemetry packets. Similar to the results from Capt Booth's tests, the team noticed a slowdown of received telemetry during the algorithm tests, but the team also saw another effect. The commands appeared to be generated at a higher rate than could be processed by the system, resulting in a queue of commands. The aircraft could not be manually commanded to other navigation modes while the commands in the queue were being processed. Also, the aircraft designated for manual control could not be changed. This

caused a loss of operator control over the vehicles, although the commands in the queue could still be overridden by manual inputs from the RC controller. The size of the queue and corresponding length of control loss varied with the amount of time of each collision encounter, apparently related to the time the algorithm was actively generating commands.

### *Video Reception*

In addition to autopilot communications, the team tested the ability to receive and display four simultaneous video feeds. The test setup was ultimately successful in this effort, as seen in Figure 13, but the team encountered numerous problems. First, hardware malfunctions in aircraft cameras and camera pod connections caused there to be less than four fully functional aircraft on all but the last flight test date. Second, the sheer amount of equipment used in video reception and capture made for a very complex and less reliable system. The number of connections between pieces of equipment was upwards of 40 components, depending on the exact configuration. Troubleshooting loose connections and hardware settings was difficult. Lastly, even when all the equipment and connections were working, the video from the BATCAMs was not of good quality. Video distortion also occurred whenever the aircraft faced towards or away from the ground antennas due to the orientation of the video antenna on the aircraft. Also, the lateral instability noted in the aircraft performance section was apparent even after thorough aircraft tuning. This caused the video image to constantly move as the BATCAM rolled and was particularly noticeable when using the side cameras.

The Quad Video device used to generate the split-screen display was useful in simultaneously capturing four video sources. However, limitations of this

implementation are that each video source cannot be recorded separately and the overall resolution of each screen is reduced when more than one feed is displayed on the same screen. To attempt to overcome these limitations, the team tested a Swann USB 2.0 DVR Guardian™ multi-source video capture device. This component accepted four analog video signals, converted them to digital streams, and transmitted them to the computer through a single USB cable. The included software performed the functions of the Quad Video and DVR hardware, displaying the feeds in various formats and recording them independently; however, the USB connection was a limiting factor in video bandwidth. When four video feeds were connected, the frame rate dropped to an unacceptably low level of around 2-3 Hz. Though there are card-based video capture solutions that can handle multiple video sources at high frame rates, this is the only type of all-in-one commercial solution the team found for capturing multiple video streams to a laptop. Unfortunately, it does not appear viable for an aerial surveillance system due to the poor frame rate.

#### *System Impact.*

Communications limitations are a large concern to a system like the CUSS. The above test results show that increasing the number of aircraft to achieve surveillance objectives carries a significant consequence in terms of communications bandwidth used. The chosen communications scheme must balance data rates with data integrity. As the number of aircraft is increased, structured communications, such as polling or set transmission time slots, become more important in ensuring packet deconfliction.

The increased communications load from Capt Booth and Mr. Smith's algorithms also suggests that this type of tight, centralized control is not ideal for preserving

bandwidth. Any implementation of the CUSS should strive to minimize this load by reducing the amount of data passed, the rate of commands, or possibly decentralizing the control algorithms to the individual aircraft.

Limitations from hardware/software implementations, such as the command queue observed in Mr. Smith's tests, can have significant impacts on system performance. This type of scheme should be avoided in any function that is significantly time dependent or where human override control must be maintained. A more sensible plan for tight control of UAVs overwrites the current command with the latest received command, rather than storing it in a queue.

The complexity of the video capture system affects the portability and reliability of the fielded components. The performance of the system must be balanced against the size and weight requirements for the intended user. The test video setup was not portable or reliable. Additionally, the performance of the control system can greatly affect the quality of the collected sensor data, not just in terms of platform stability, but also from the ability to place the aircraft and sensor in the optimal position to observe the target.









#### ***Human Factors Observations.***

Though no specific human factors studies were performed, the team recorded several observations during the course of ground and flight testing.

##### *Operator Workload.*

The team was very concerned with the workload on the ground station operator during testing for safety concerns. The pilot with the RC controller could override the autopilot if something went wrong, but could only control one aircraft at a time. The team developed very specific test procedures to ensure that the aircraft in the most critical

phase of flight (e.g. closest to the ground, taking-off, landing, etc.) was designated as ready for manual control. This designation was made by clicking in a checkbox under the “RC” column in the agent list of Virtual Cockpit™, shown in Figure 51. Having to keep track of designating the appropriate aircraft and communicating this to the pilot was initially a significant burden on the operator and often became confusing. However, as the team got used to the procedures and expectations were established, this became less of a factor.

Address	Comm	Batt	Altitude	Velocity	Sat	RC
1			10.6	510 ft	17 kts	10
2			11.2	266 ft	18 kts	10
3			11.4	361 ft	20 kts	10
4			10.6	170 ft	25 kts	10 <input checked="" type="checkbox"/>

**Figure 51. Virtual Cockpit™ Agent List**

In a similar vein, to manually send commands to an aircraft from Virtual Cockpit™, the appropriate aircraft had to be highlighted in the agent list. In Figure 51, aircraft # 4 is highlighted. The fact that the “RC” checkbox was independent from the highlighted agent added to the confusion of controlling multiple aircraft.

The tracking of aircraft parameters was less of a factor. The aircraft position was displayed as a graphic overlay on the map screen, as shown in Figure 52. Additionally, the aircraft could be color coded to tell them apart, and key telemetry data (agent number, altitude, airspeed) could be displayed next to their icons. The fact that altitude was only displayed digitally, and not graphically, did make it difficult to simultaneously monitor multiple aircraft altitudes. In all cases, the observers visually monitoring the aircraft

noticed uncommanded altitude changes well before the operator controlling Virtual Cockpit™.

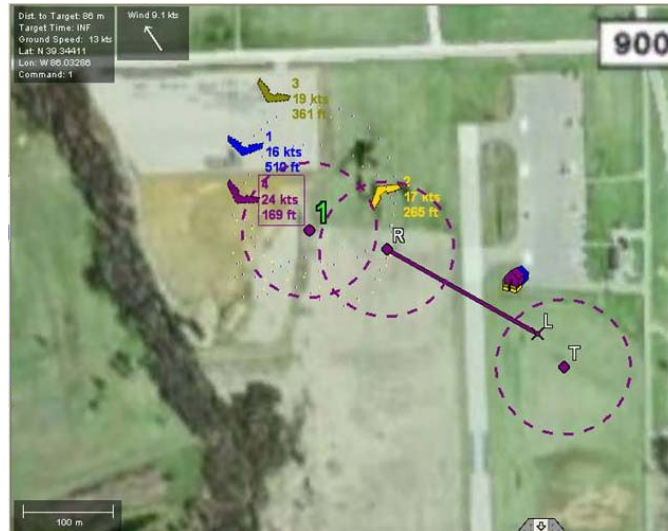

**Figure 52. Virtual Cockpit™ Map Screen**

Once the operator became familiar with the interface and procedures for controlling multiple aircraft, that person reported that the task of conducting a four-ship flight was not difficult. However, until the aircraft were established in a set pattern such as an orbit or series of waypoints, the operator paid almost no attention to the video display from the aircraft cameras. Tasks such as launching and recovering aircraft, changing aircraft altitudes, and running test algorithms completely distracted the operator from monitoring the aircraft sensors.

*Trust in Automation.*

During the course of flight testing, the Virtual Cockpit™ operator made observations about trust in the system. This is directly related to operator workload in



that a greater degree of trust results in less monitoring of automated tasks and more time to devote to conducting and monitoring the surveillance mission.

One example of a poor design choice that led to a lack of trust was the automatic landing mode for the Kestrel™ autopilot. When “Land” mode is selected in Virtual Cockpit™, the aircraft proceeds through a series of steps, governed by the “Rally” and “Land” points in its flight plan. These points are shown in Figure 52, labeled “R” and “L” respectively. First, the aircraft flies to the Rally point at its current altitude and begins to orbit. Once it reaches the orbit, it descends to a preset altitude known as the “break altitude.” The aircraft then levels out at the break altitude and continues around the orbit to the side opposite the landing point. It then turns to line up with the course between the Rally and Land points and descends to follow a glideslope from the break altitude at the Rally point to the ground at the Land point. However, Virtual Cockpit™ gives no indication as to the sub-modes of the aircraft through this process. Therefore, the operator and pilot often found themselves confused as to whether the aircraft was lining up on final or performing another orbit at the Rally point. This was distracting, confusing, and created doubt about whether the aircraft was performing as it should.

Another example came from the implementation of Capt Booth’s cooperative control algorithm [34]. In order to get the generated waypoints to the aircraft quickly and get them moving on the desired paths from his algorithm, his interface sent waypoint packets directly to the aircraft, rather than as a packaged flight plan through Virtual Cockpit™. This resulted in a state where the aircraft had received the new waypoints, but the waypoints displayed on the Virtual Cockpit™ interface were from the old flight plan. This was procedurally remedied by the operator manually requesting a download of

waypoints from each aircraft to Virtual Cockpit™. However, the mismatch that existed before this step was complete again decreased trust in the system.

#### *System Impact.*

Human Factors considerations must be designed into a system like the CUSS. A well designed user interface and control scheme will help the operator conduct missions more efficiently. In the case of a single operator, this will allow more time to monitor the surveillance sensor feeds. Decreased operator workload becomes even more critical as the number of aircraft controlled increases and the environmental conditions of the operator (e.g. temperature, restrictive clothing, enemy fire, etc.) worsen. An additional part of human factors considerations is required improvements to systems trust that allow the operator to concentrate on the mission tasks rather than focusing attention on automated processes. Enough information must be available to facilitate system trust, but it must be presented in a way that is not overwhelming to the user. For example, the landing sub-mode could be displayed by mousing over the “Land” mode indicator button. Also, the system should not take control away from the operator unless for a well thought-out safety reason.

#### **Risk Areas**

During the evaluation of the CUSS conceptual architecture and flight testing, a number of risk areas were identified that impact the future feasibility and ultimate capability of UAS operations. While the scope of this effort did not include in-depth

research in each of the following areas, these concerns and issues will require consideration to fully implement an effective operational cooperative control capability.

### ***UAS Performance.***

For this thesis, the BATCAM was government provided hardware and the only platform available to the team in sufficient quantities to test cooperative control behavior. While this airframe is simple, small in size, and requires a minimal logistical footprint, several significant limitations were identified during its use. Although the BATCAM is readily man-packable, its small size and weight make this airframe very susceptible to winds. Compared to the heavier and larger SIG Rascal airframe used by Capt Farrell [33] and ENS Vantrease [31], the BATCAM had a difficult time achieving programmed waypoints and maintaining acceptable airframe stability as identified during the flight testing of Capt Farrell's algorithm. Future use of this test bed system will require evaluation of actual wind speeds observed during flight testing and their impact on obtaining useable data. The development of future software algorithms associated with mission planning and execution should also carefully consider both UAV capabilities and sensor requirements to ensure the composite system is able to deliver the types and quantity of data requested from the mission tasking.

### ***Endurance.***

The BATCAMs may be suitable for short duration and quick-look surveillance observation of a target, but their utility for longer duration missions or operating at extended distances diminishes due to the overhead times associated with launch, recovery, and travel time to the target. To field a UAS capable of cooperative control

behavior, higher endurance platforms are necessary to provide ISR collection capability at extended ranges and for long loiter times.

In a scenario where an operator is tasked to provide persistent surveillance on a stationary target, a formation of four vehicles could be used to provide assured coverage. Assuming an average of two minutes to launch each vehicle in the four-ship formation, one minute of transit time to station, and one minute to recover each vehicle at the end of the mission, total four ship coverage of the target, assuming 20 minute endurance, is only 12 minutes. This is shown in Figure 53.

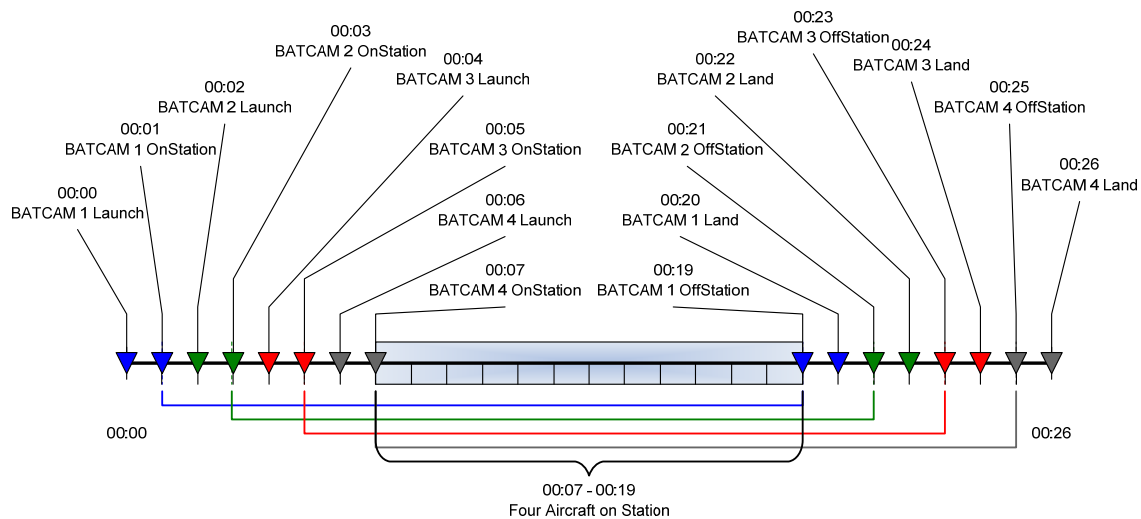

**Figure 53. Four Ship Persistent Surveillance Scenario – Small Battery**

Assuming a 40 minute endurance with the larger 2100 mAh batteries, time over target with a 4-ship formation would increase to 32 minutes as shown in Figure 54.

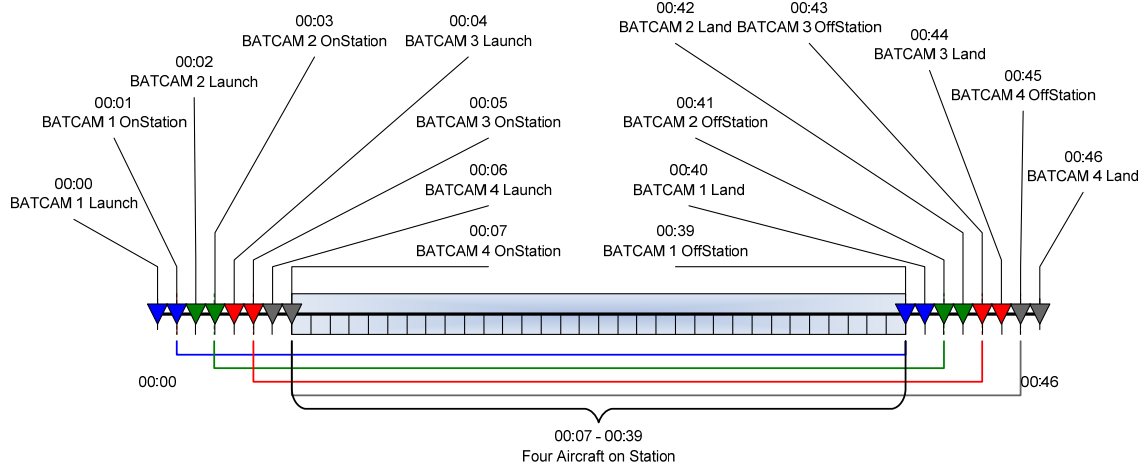

**Figure 54. Four Ship Persistent Surveillance Scenario – Large Battery**

***Communications.***

*Communications Bottleneck.*

Throughout flight testing, the team encountered a number of situations where a communications bottleneck occurred. This phenomenon was especially apparent during flight testing of Capt Booth’s cooperative control algorithm Mr. Smith’s collision avoidance algorithm, as previously discussed. In order to mitigate this risk, future research must be conducted regarding how to increase processing power on the airframe and ground station, increase channel bandwidth, separate commands, telemetry, and sensor data by frequency, or restrict the amount and rate of control data to the minimum that can be reliably processed.

*Digital vs. Analog Sensor Data.*

One way to restrict the data flow of the system is to reduce the amount of sensor data being transmitted from the airframe to the ground station. The system, in its current configuration, transmits analog sensor data from each airframe. As the number of

airframes increases, the reliability of the sensor video display decreases. In order to mitigate this risk, the team recommends research into transmission of digital sensor data from each airframe to reduce the amount of bandwidth consumed by sensor data transmission.

#### *C2 & Data Relay Capability.*

Real-world UAS operation would likely require cooperative formations to fly at extended distances and operate in an environment where they are beyond line-of-sight of the operator. In each of these scenarios, it may be necessary for one or more UAVs within the formation to operate as a two-way relay platform between other UAVs and the ground station. This capability would greatly expand the types of missions UASs can be tasked to do, but would also introduce additional challenges.

One of the largest risks with using UAVs as relay platforms is the potential for a communications bottleneck at the relay node. If communications traffic exceeds the capability of the relay node, communication packets and vital navigation data may be dropped, which could lead to a lost communications scenarios and/or loss of a vehicle. Additionally, mission data collected by the formation might also be delayed or dropped enroute to the ground station, potentially resulting in serious consequences to the operators receiving and acting upon the mission data.

Although the MaxStream modem has an advertised range of 14 miles and includes a relay capability to pass C2 and mission data between platforms and the ground station, the team never fully investigated this functionality. Throughout flight testing, the team kept the BATCAMs within visual range and limited flights to less than a 0.5 mile radius of the ground station at all times. Although the team performed a satisfactory

stationary ground test with 1.55 miles between the BATCAM and the ground station, further evaluation of the performance range and relay capability of this modem is required to mitigate the risks associated with long range communications.

#### *Secure Communications.*

Real-world UAS operations would also likely require data encryption, especially in hostile territory. In turn, data encryption creates technical and logistical problems that must be addressed at the Theater level or higher. At the system level, encryption also creates additional data overhead which could create or exacerbate some of the communications problems described in the previous sections. A thorough evaluation of throughput limitations must be conducted prior to implementing any encryption scheme with this system.

#### *Distributed vs. Centralized Processing.*

An alternate solution to reducing communication flow between the base station and multiple UASs is increasing the processing power onboard each UAS, and better utilizing distributed algorithms for navigation and formation management. Dr. Derek Kingston, for example, has researched the feasibility of a distributed solution to optimizing surveillance of a path with multiple UAVs [26].

Procerus advertises the ability to reprogram its autopilot, but the team did not investigate this capability. Future teams examining the distributed algorithm approach would need to research using the autopilot processor to execute control algorithms, adding additional processing power to the autopilot, or adding an external processor to the aircraft.

### ***Video Capture Limitations.***

Digitally converting the video signal of four individual video streams and sending those four images to a single laptop created a communications bottleneck at the USB port, resulting in an unacceptable frame rate on the video display. This problem was circumvented by either viewing the video streams on an external device, or combining the four feeds into a single quad-format display. The problem with the former solution is portability. The problem with the latter solution is the inability of the user to manipulate or isolate any single stream. Future research into sensor data throughput and video capture technology must be conducted if the ground system is to be operated solely from a laptop computing device.

### ***Human Factors Issues.***

#### ***System Trust.***

With any remote operation of UASs, system trust, or confidence in the system to do what the operator expects it to do, becomes an important factor. When flying a single UAV, the operator is able to concentrate his or her efforts on ensuring the UAV is executing the assigned tasking and quickly correcting any anomalous behavior. As the number of airborne UAVs increases, operator attention is divided and it becomes difficult to monitor every aspect of UAS operation. Although the test bed proved to be a reliable and robust system for flying up to four UAVs simultaneously, Mr. Smith's and Capt Booth's algorithms still stressed the test bed's ability to effectively pass command and telemetry data between the BATCAMs and ground station.

Future utilization of the test bed should include interfaces and algorithms that provide positive feedback to the operator. This includes acknowledging acceptance of



command inputs and quickly notifying the operator of changes in aircraft or algorithm condition or state. Future algorithms should also include an override function that restores immediate control to both the operator and safety pilot in the event that a command or telemetry bottleneck impairs communication with the UAS.

#### *Effective Formation and Sensor Management.*

The test bed systems also identified the difficulties of operating the UAVs while simultaneously viewing the video feed provided by each platform. While the test bed was capable of displaying the video feed on the same screen as critical aircraft status information and algorithm information, additional human factors research is required to determine exactly how many aircraft and the amount of information that can reasonably be processed by a single operator. Mitigation of this problem may involve separating system and sensor operator responsibilities between two or more individuals for more effective management of cooperative control platforms.

#### *Interfaces.*

Proper interfaces are essential when dealing with any system designed to be compatible with various types of hardware. The CUSS concept envisions controlling multiple types of UAVs and sensors through common hardware. The physical and logical interfaces used to gather aircraft and sensor status, transmit collected sensor data, and pass aircraft and sensor control commands should ideally be standardized; however, it may not be practical to do so on the aircraft side due to the wide variety of UAVs currently in use. One potential solution is to use multiple “flavors” of CUSS airborne hardware in order to accommodate the various aircraft sizes, power configurations, and interface types available within the DoD UAV inventory.

Similarly, to be compatible with multiple ground station setups, the CUSS would need to handle differing operating systems, processor and memory capabilities, and communication port configurations. Again, multiple “flavors” of CUSS ground hardware may be required to handle different computer and communications antenna arrangements. This also may be required to keep overall size and weight to a minimum for a man-portable setup, while offering increased capabilities at the cost of increased size and weight for a larger, fixed-base setup.

### ***Integration into the National Airspace System.***

Current FAA regulations prohibit the operation of any government controlled UAVs within the NAS unless flight operations occur in restricted air space or the FAA grants a specific authorization. This places significant restrictions on flight testing of UASs and can hinder their development. UAS developers can continue to push the FAA towards establishing reasonable flight rules, but they must also examine measures to make UASs more compatible with the current NAS. This includes installing equipment like transponders as well as developing flight safety technologies like active traffic detection and avoidance.

## V. Summary and Recommendations

### Summary

The goals of this thesis were to develop a conceptual systems architecture to address current capability gaps and user needs associated with providing cooperative control of multiple UAVs from a single control unit and provide a test bed for concurrent and future research associated with cooperative control of multiple UAVs.

In addition to expanding upon these goals, Chapter I addressed the scope and assumptions of the thesis. Chapter II provided background on the broader ISR mission that this system is designed to support, a brief history and description of UAVs and UASs, a description of the growing demand for UASs in a number of areas, a description of cooperative control, and a recap of recent and concurrent research of UASs and their employment in a number of operational scenarios. Chapter III described the methodology that the team used to develop the conceptual and test architecture products depicted in this thesis, the components used to build the test bed system, the procedures used to conduct ground and flight testing for this system, and the technological risks associated with this and future flight tests. Chapter IV detailed the architectural products created by the team in support of this thesis, the results of flight testing, the performance of specific hardware and software components associated with the test bed system, and an analysis of risk areas identified throughout the process.

## Remarks

This thesis expanded on previous UAV research, specifically research conducted at AFIT by LCDR Sakryd and Capt Ericson [29], and Maj Laird, *et al.* [28]. The team produced a conceptual architecture to address a broader area of current and future research and a test architecture to describe the system constructed for the flight tests conducted in support of this thesis. The conceptual architecture is not tied to any particular aerial or ground platform and is therefore highly scalable. The test architecture and associated test bed were also constructed to address specific areas of the conceptual architecture the team intended to validate.

Over a period of six months, the team conducted a series of five flight tests in support of this thesis. Throughout the flight testing process, the team successfully demonstrated the ability to fly multiple UAVs from a single ground station and the ability to incorporate cooperative control algorithms developed in concurrent research.

## Recommendations

### *Seek UAV Operations at WPAFB.*

Due to current FAA restrictions, the team had to conduct all flight testing at Camp Atterbury, near Edinburgh, IN, nearly 160 miles away from WPAFB. While the lack of proximity of the flight test site to WPAFB did not prevent the team from successfully completing all flight testing required to support this thesis, the logistics associated with planning and conducting flight test at such a remote location proved to be a significant obstacle to addressing problems associated with and discovered during flight testing. To

expand flight test prospects, personnel within AFRL/XPTT, with support from AFIT, are awaiting FAA regulation changes that would allow UAV flight operations to resume at Wright Patterson AFB. Future research teams should periodically contact AFRL/XPTT to obtain the latest status of this effort and provide amplifying data as necessary to encourage UAV flight operations in other than restricted airspace.

### ***Reexamine Airframe Selection.***

The BATCAM UAV was chosen due to its small logistical footprint, its availability to the test team, and the GOTS hardware and software available to support ground and flight testing. While flight testing was considered successful using this airframe, the SIG Rascal airframe used in previous testing proved to be a more stable platform. Of particular concern to the test team was the lateral stability associated with the BATCAM, and the susceptibility of the BATCAM to high or gusty winds due to its light weight and slow cruising airspeeds. The team recommends investigating the use of a more stable airframe for future flight testing.

If the decision is made to continue use of the BATCAM, the team recommends performing another round of autopilot tuning. Further refining the PID values for the autopilot control loops could result in a more stable platform for testing student-developed control algorithms.

### ***Create a Robust/Common Development Interface.***

Based on the research of LCDR Sakryd and Capt Ericson [29], the team chose to use the C++ development interface provided in the Virtual Cockpit™ software development kit as a basis for the algorithm interfaces developed by Capt Booth and Mr. Smith. Each algorithm tested with the system, however, used a different interface to

interact with Virtual Cockpit™. While the interfaces proved successful in ground and flight testing, each was extraordinarily sensitive to changes in packet structure associated with the two different versions of Virtual Cockpit™ used during the flight test program. The team recommends the development of a common Model-View-Controller based interface, tailorable to individual algorithm needs. By maintaining a common controller, future researchers can adapt the model to changes associated with Virtual Cockpit™ software updates, and the view based on user needs and preferences without having to change the basic functionality of the controller portion of the software.

***Utilize the Latest Hardware and Software.***

The current Kestrel autopilot is very adaptable to a number of platforms, and Procerus publishes frequent updates to its software to improve functionality and provide new features. Although product support is readily available through Procerus for current versions of their products, support for previous versions of hardware and software is limited. As a result, this team recommends flying the latest version of available products to ensure some level of product support is available through Procerus. Moreover, future researchers should conduct periodic reviews of available autopilot products to determine if better systems exist for advancing UAS cooperative control capability and technologies.

***Investigate On-Board Processing Power and Implementation.***

Based on the packaged configuration of Virtual Cockpit™, most of the processing involved with airframe control and algorithm implementation was conducted at the ground station. Bandwidth became an increasingly significant risk area as the number of airframes and the complexity of the control algorithms increased. This risk was mitigated

somewhat by the implementation of a polling feature included in Virtual Cockpit™ to reduce the amount of lost data associated with the packet collisions and/or processing delay created by multiple airframes communicating on a common frequency; however, as demonstrated by the last flight test, communication bandwidth issues still proved significant. To reduce the effect of bandwidth as a limiting factor in control and algorithm implementation, the team recommends further investigation to increase the onboard processing and algorithm computation capability of UAVs and future UASs.

### **Future Areas of Study**

#### ***Channel and Bandwidth Deconfliction.***

In addition to bandwidth shared among the multiple airframes associated with this system, the team believes that future users will face channel deconfliction issues with other wireless communication systems within a theater of operations. Chief among these issues are adapting to established protocols already in existence and mitigating the risk of operating in the vicinity of systems not using any established protocols. The team recommends investigation into protocols and strategies to mitigate these situations.

#### ***Distributed vs. Centralized Control.***

Distributed control of multiple airframes could significantly reduce the communications footprint associated with this system. The team recommends investigation into the feasibility of developing and implementing decentralized control algorithms for multiple UAVs.

### ***Communication Relay Capability.***

Long distance and beyond line-of-sight surveillance will require a relay capability to issue control commands to, and receive surveillance data from multiple UAVs. While the MaxStream modems used in the test bed system have a relay capability, the use of one or more UAVs as a relay platform was beyond the scope of this thesis. The team recommends investigating the use of UAVs as effective relay platforms and the development of an architecture that would permit effective relay operations.

### ***Minimum Parameter Set.***

The team envisioned a control system that can be employed on multiples types of vehicles. To enable this, the cooperative control algorithms must be based on a set of aircraft parameters, rather than being tailored to a specific vehicle. The team recommends researching a minimum set of parameters that characterizes each UAV type as it interacts with the control system.

### ***Operator Trust and Workload.***

Although the team noticed a significant increase in operator workload as the number of airborne UAVs increased, the human factors aspect of flight testing was largely considered beyond the scope of the thesis. The team recommends the future investigation of human factors issues associated with the control of multiple UAVs by a single operator from a single ground control station.



## Appendix A: List of Acronyms

AFB	- Air Force Base
AFIT	- Air Force Institute of Technology
AFRL	- Air Force Research Laboratory
AV	- All View
C2	- Command and Control
C2ISR	- Command, Control, Intelligence, Surveillance, and Reconnaissance
C4ISR	- Command, Control, Communications, Computers, Intelligence, Surveillance, and Reconnaissance
CD	- Computing Device
CCD	- Charged Couple Device
CDF	- Cumulative Distribution Function
CESI	- Cooperative Engineering Services Incorporated
COCOM	- Combatant Command
COLA	- Collision Avoidance
COTS	- Commercial Off-the-Shelf
CONOPS	- Concept of Operations
CUSS	- Cooperative Unmanned Surveillance System
DHS	- Department of Homeland Security
DLL	- Dynamic-Link Library
DoD	- Department of Defense
DoDAF	- Department of Defense Architecture Framework
DVD	- Digital Video Disk
DVR	- Digital Video Recorder

FAA	- Federal Aviation Administration
FEMA	- Federal Emergency Management Agency
FOB	- Forward Operating Base
FOV	- Field of View
GCH	- Ground Communications Hardware
GOTS	- Government Off the Shelf
GPS	- Global Positioning System
HIL	- Hardware-in-the-Loop
HQ	- Headquarters
ICOM	- Input, Control, Output, or Mechanism
I/O	- Input/Output
IP	- Internet Protocol
ISR	- Intelligence, Surveillance, and Reconnaissance
JCIDS	- Joint Capability Integration Development System
LiPo	- Lithium Polymer
LOC	- Lines of Communication
LOS	- Line-of-Sight
MAV	- Mini/Micro Aerial Vehicle
MSR	- Main Supply Route
NAS	- National Airspace System
OSD	- Office of the Secretary of Defense
OV	- Operational View
PID	- Proportional/Integral/Derivative
POI	- Point of Interest

PPS	-	Packets Per Second
QDR	-	Quadrennial Defense Review
RC	-	Remote Controlled
RF	-	Radio Frequency
RMS	-	Root Mean Square
SAR	-	Search and Rescue
SatCom	-	Satellite Communications
SIL	-	Software-in-the-Loop
SQL	-	Structured Query Language
SRB	-	Safety Review Board
SV	-	Systems View
TCP	-	Transmission Control Protocol
TRB	-	Technical Review Board
TV	-	Technical View
UAS	-	Unmanned Aircraft System
UAV	-	Unmanned Aerial Vehicle
USB	-	Universal Serial Bus
WPAFB	-	Wright-Patterson Air Force Base

## **Appendix B: CUSS Concept of Operations**

### **Purpose**

The purpose of the Cooperative Unmanned Surveillance System (CUSS) is to provide a revolutionary surveillance capability to forward deployed users that uses multiple UAVs to cooperatively execute assigned taskings. This system will utilize an overarching architecture and common interface that enables the command, control, and communications to and between multiple UAVs simultaneously. The CUSS is capable of conducting a wide variety of UAS missions and will display collected intelligence data to distributed users through its common interface. The CUSS is also a software intensive system that will utilize common hardware components to achieve the flexibility necessary for a variety of mission taskings and is adaptable to a variety of aerial platforms and user interfaces.

### **Time Horizon, Assumptions and Risks**

#### ***Time Horizon.***

The CUSS is being designed in response to current threats and user needs from the warfighting community. The capabilities the CUSS will deliver are needed today and well into the foreseeable future. The concept CUSS will be demonstrated by developmental testing in early 2009 and systems capabilities will continue to evolve with respect to both technology and warfighter needs throughout the life of the concept. First generation deployable CUSSs are targeted for delivery within the next three to five years.

### *Assumptions.*

#### *Doctrine.*

The CUSS is expected to provide Combatant Commands (COCOMs) faster and higher quality intelligence data than was previously available. As such, warfighter doctrine will need to be updated across the battlefield to better utilize CUSS capabilities and increase the operational and tactical reach of personnel executing the warfighter mission. The CUSS will also require that DoD component services work in concert with one another to share and utilize assets effectively in a combat theater. Properly utilized, the CUSS also provides seamless interoperability and enables the sharing of assets among distributed users to obtain the maximum intelligence value from available platforms and sensor packages.

#### *Organization.*

The CUSS is designed to be employed with UASs operated by deployed units. In the cases of UAS hardware assigned to a theater of operation, the CUSS assumes that the COCOMs will effectively organize and distribute the assets to units deployed within the theater.

#### *Training.*

It is assumed that appropriate training will be made available for personnel to effectively and efficiently operate the CUSS.

#### *Materiel.*

The CUSS requires common hardware and software components to be installed within separately procured UAVs. The system is not dependent on any particular

airframe and is readily scalable from micro UAVs to large scale vehicles currently in use. Units or services operating the CUSS will be responsible for procuring sufficient numbers of CUSS components to operate their UASs.

*Leadership.*

Due to the expanded intelligence gathering and multi-mission capabilities the CUSS provides, significant leaps in operational and tactical execution are expected. Leadership will be required to train and modernize their forces to fully utilize the new capabilities the CUSS will bring to the battlefield.

*Personnel.*

The CUSS will enable one or two operators to simultaneously control a formation of multiple UAVs. As a result, the overall number of personnel devoted to the operation of UAVs will eventually decrease as the CUSS is fielded.

*Facilities.*

The CUSS will have a negligible impact on facilities. Initially designed as a tactical, readily expandable system, the CUSS will likely re-utilize existing space already in use by other UASs. It is also assumed that forward deployed facilities will have the capability to store, maintain, and support CUSS components.

*Risks.*

*Doctrine.*

The Joint community may not immediately embrace the capabilities provide by the CUSS. With current UAS operations, each service operates their own type and variety of UAVs, responds to their own services taskings, and is not concerned for the needs of operators outside their own service or unit. As a result, UAVs on today's battlefield are

not interoperable and cannot effectively work together in a formation or when combined with another operational unit. The CUSS will enable users to fly multiple UAVs simultaneously and provide unmatched surveillance and intelligence gathering capability. Data collected by CUSS assets can then be viewed by numerous distributed users across the battlefield. Once the usability and mission benefits of the CUSS are understood, interoperability concerns within the Joint community will decrease.

#### *Organization.*

The CUSS will require more streamlined and direct control of UAV assets under a COCOM. Once the mission capabilities and limitations are understood, it is expected that necessary changes to UAV operations will be made to optimize the use of the CUSS and UAS assets.

#### *Training.*

Insufficient training on the use of the CUSS will result in less than optimal surveillance and data collection capabilities and could result in the loss of mission UAVs. Training and training support will be critical to the effective use of the CUSS.

#### *Materiel.*

The CUSS is an integrated materiel system that requires sufficient quantities of hardware, software, and spares to effectively operate. The CUSS will require sufficient funding to realize the benefits it promises.

#### *Leadership.*

Leadership may become wary of transferring their assets to another unit or operational entity and then later having those assets returned to them at the end of a

mission. Top level direction and experience with the CUSS will enable commanders to appreciate the full complement of benefits the system can provide to warfighters.

*Personnel.*

The CUSS will require an initial increase of personnel within the UAV community as it is deployed. Once the system is operational, it is expected that fewer operators will be able to effectively operate more UAVs and lead to an eventual reduction of personnel assigned to UAV operations. However, a central cadre of highly trained personnel will be required to provide operational training and technical support to system operators.

*Facilities.*

The CUSS may require a central facility for handling repairs, housing technical support personnel, and generating training materials for operational units.

## **Military Challenges**

*Mission Statement.*

Provide real-time multiple UAV ISR capability to forward deployed users and COCOMs. The CUSS will provide integrated command, control, and information gathering capabilities that can be displayed to numerous users through a common interface.



## ***Concerns.***

### ***Bandwidth Limitations.***

The rapid growth of wireless systems on the battlefield will constrict the availability of bandwidth for use by the CUSS and potentially limit its capability.

### ***Frequency Deconfliction (External).***

The CUSS will likely compete with existing systems for bandwidth and frequency usage. Theater-level coordination will be required to manage the use of the CUSS and any other systems operating in the wireless communications medium.

### ***Frequency Deconfliction (Internal).***

The CUSS will have multiple video and data feeds competing for resources within the scope of its own allotted frequencies and bandwidth. Collision avoidance algorithms and protocols will be required to allow multiple resources to communicate on the same wireless network.

### ***Throughput Limitations.***

The CUSS will require processing power on both the ground station and aircraft to process multiple video and data streams. The overall size and capability of the airborne platform may limit the quantity, quality, and timeliness of intelligence data collected by the CUSS.

### ***Secure Communications.***

The CUSS will require a secure communications network to prevent unauthorized or hostile interception of video and/or data streams.

### *Onboard vs. Ground Processing.*

The CUSS will require a tradeoff study to determine the optimum distribution of processing power between the ground station and UAV platforms. Risk issues include the weight of UAV platforms, required size, weight and power of on-board processors, required foot print of ground control stations, and impact to communications bandwidth.

### *Human Factors.*

The CUSS will require a human factors study to determine how effectively single or multiple individuals can control and monitor multiple UAVs and video streams simultaneously from a single interface.

### *Size, Weight, and Power.*

The CUSS will require a tradeoff study to determine the optimum combination of size, weight, and power, based on user defined requirements. Multiple versions of CUSS hardware may be required to support UAVs and operational units of various size, capabilities, and interfaces.

### *System Maintainability.*

The CUSS will require forward deployed maintenance capabilities and technical support for both software and hardware components.

## **Synopsis**

The purpose of the CUSS is to provide an agile, responsive, and user-oriented airborne surveillance system that is focused on the tactical and operational levels of war.

The CUSS will utilize an overarching architecture that combines common hardware

components with a user-friendly software system that enables system operators to surveil a variety of targets with multiple UAVs. The system is capable of being controlled by a single user and displaying data to multiple distributed users. The system shares hardware components and software protocols to ensure it is expandable and interoperable between a variety of UAV platforms. The CUSS is not specific to a single type of UAV platform or host computer system.

The primary components of the system include: 1) control software; 2) mission planning software; 3) display software; 4) ground and airborne communications transceivers; 5) airborne processing and control hardware; 6) and software to produce an exportable surveillance product.

### **Desired Effects**

#### ***“TiVo” Capability.***

The CUSS will provide the user the capability to display, playback, record, and manipulate a sensor data stream. The system will also enable this data to be exported to external distributed users.

#### ***Persistent Surveillance.***

The CUSS will provide the user persistent surveillance of a route, search area, or other designated target. Uninterrupted coverage will allow a user to examine a given area over an extended period of time.

### ***Enhanced Sensor Coverage.***

Through the use of multiple UAVs, the CUSS will provide improved sensor coverage and situational awareness above and beyond what a single UAV platform can provide.

### ***Reduced Revisit Time.***

The CUSS will provide reduced revisit time of areas or targets of interest through the use of multiple UAV platforms and cooperative control algorithms designed specifically for a variety of mission types and specialized tasks.

### ***Adaptable Sensor Coverage.***

The CUSS will provide variable and programmable sensor coverage patterns using a variety of sensor systems based on mission taskings.

## **Necessary Capabilities**

### ***Communications Hardware.***

The CUSS requires hardware to send secure C2 information to and receive secure position, telemetry, and intelligence data from multiple UAVs at extended ranges. Communications systems employed by the CUSS must avoid becoming saturated by outside networks and should minimize the overall system load placed on battlefield communications. Consideration should be given to dynamic assignment of bandwidth as well as utilization of commercial networks to provide the secure communications necessary to operate the CUSS.

### ***End User Equipment.***

The CUSS must be compatible with existing C4ISR networks and capable of visualizing, using, and transporting surveillance products created by the CUSS.

### ***Control Algorithms.***

The CUSS requires algorithms to optimize control of multiple UAVs for various tasks. Tasking includes, but is not limited to, formation manipulation, optimization of coverage area, flight path deconfliction, collision avoidance, sensor placement optimization, flight path optimization to keep a target in a UAV's fixed sensor field-of-view, convergence of multiple UAVs on a single target, and terrain avoidance.

## **Enabling Capabilities**

### ***Responsive Launch and Recovery.***

The CUSS requires effective and efficient launch operations to initiate a mission and provide sufficient mission coverage, platform replenishment, and persistent surveillance in response to mission taskings. Effective and responsive UAV recovery is also necessary to prepare for re-launch of mission platforms or for subsequent taskings.

### ***Precision Geolocation.***

A precision source of position and velocity data, such as the Global Positioning System (GPS), will be required for operation of the CUSS. This system will be used to calculate accurate coordinates for all UAVs in a formation, provide waypoints for the navigation of UAVs, and describe target locations from data collected by the UAVs.

### ***Communication Enablers.***

Sufficient digital communication devices are necessary for high rate data transmission at beyond line-of-sight ranges, up to several hundred kilometers. These communications should be capable of direct ground station to UAV communications, as well as UAV to UAV communications to enable the relaying of information between the ground station and most distant UAV.

### ***Beacon Following Capability.***

Beacon following technology must be available to enable the system to locate and track a fixed or moving target that emits a detectable signal. This device will forward GPS coordinate information to the ground system and be used to navigate UAVs in accordance with target movement and UAV formation plans.

### ***Host Computer.***

A host computer with a commercially available and maintainable operating system (such as Windows XP or Linux) and nominal processing power and memory will be required for proper operation of the CUSS C2.

### ***UAV Platform and Sensors.***

Multiple UAVs with a sensor package (such as video, infrared cameras or synthetic aperture radar) are required for operation of the CUSS. These platforms and onboard sensors must be capable of receiving control commands from the CUSS hardware. The platforms must be capable of passing sensor data to the CUSS transceiver. The platforms must also have the range, endurance, flight characteristics, and sensor characteristics specific to the user's desired mission tasking.

## **Sequenced Actions**

### ***General System Functions.***

General system functions are inherent to all missions. Minor variations to these functions are made by the user based upon multiple factors, such as mission requirements, terrain, environment, or launch platform.

#### ***Plan Mission.***

The user begins the development of a mission plan by taking user defined inputs such as ISR data, mission tasking, mission data, airspace control measures, target list, UAS flight status, and an asset list and entering these into CUSS software hosted on the Computing Device (CD). The software then develops and generates a mission plan that when executed, will achieve the overall mission objectives. Once the mission plan is complete, the CD sends the information via the Ground Communications Hardware (GCH) to the UAS. The mission plan is typically uploaded to each UAV before launch but real-time updates to the mission plan can be forwarded to UAVs at any time after launch.

#### ***Deploy System.***

The user wishes to deploy multiple UAVs. The user sets up all necessary ground support equipment and uploads a planned mission to the UAVs. The user launches the UAS in a direction dictated by wind, obstacles, and mission requirements. Once airborne, the UAS begins mission execution at the direction of the user.

### *Re-plan Mission.*

While flying and executing an existing mission plan, additional information becomes available that requires a new mission or re-planning of an existing mission. If flying an existing mission plan, the user monitoring the CUSS identifies a new target of interest or determines the need for a new mission tasking. Mission plans, once generated, are static until new information requires an update to the mission plan. A mission re-plan can be initiated either by the user or by automation, triggered by a change in the mission status, collected surveillance data, or new C2 takings. This information is loaded in the CUSS software and is used to generate a new mission plan that results in the re-tasking of mission assets. Once the plan is complete, the CD sends the information via the GCH to the UAS. The UAS then begins executing this new mission plan and transmit the sensor feeds to the user via the CUSS. The mission plan can be uploaded to each UAV either before launch or after the UAV is airborne if an update to the mission plan is necessary.

### *Manage the UAVs.*

Once the UAVs are airborne, the CUSS software and airborne control hardware utilizes the current mission plan, UAV system status, UAV positions, sensor gimbal angles, and sensor commands to direct the UAV flight paths and ensure the mission plan is effectively and efficiently being executed. This function provides flight commands to position the UAVs where needed and to maintain UAV position, ensure collision avoidance (COLA), and optimize sensor collection opportunities and geometries. The CUSS software will communicate via the GCH and upload control commands to the UAVs performing a mission. Additionally, this function will measure current UAV



telemetry data, and produce UAV flight status and mission status information to be monitored by the users.

#### *Control Sensors.*

UAS sensor control utilizes platform position, sensor gimbal angles, UAV orientation, target location, and the current video display to optimize coverage of the target or target area of interest. Combined with the overall sensor health, sensor status, and user operator commands, UAS sensor commands are generated to direct the final orientation and configuration of the sensors, such as zoom level, sensor modes, sensor tracking point, sensor auto tracking, and sensor switching if multiple sensors are present. The system has the ability to conduct these functions automatically in accordance with the mission plan or manually as a result of operator input.

#### *Manage Surveillance Data.*

The UAS and UAS sensors work in concert to collect and provide real-time data that can be displayed in a video format to both the operator controlling the system and to other distributed users. This function records, displays and outputs a video stream for the users in addition to displaying UAV telemetry data such as UAV position, orientation, gimbal angles, and target locations. The video data may also undergo automatic analysis such as automatic target recognition, movement detection, change detection, object counting, and target status dependent on the capability of the sensor and system. This function provides the fidelity necessary for the operator to fully understand all aspects of UAS health and status, sensor health, status and modes and flight telemetry to enable effective command and control of all UAS and sensor functions to execute the current mission or, as necessary, to update and re-task an on-going mission as a result of a new

target being identified or located. The system provides tools for the users to combine recorded sensor data (such as a time-stamped video feed or still picture) with extracted information (such as target coordinates and user comments) into a finished surveillance product. This can then be exported for use by other users and organizations.

#### *Manage Health and Status of UAVs.*

The system manages the health and status of each UAV tasked for a mission. If the CUSS detects a warning condition, such as low battery, low fuel, or other system anomaly the system alerts the user to the condition and recommends a course of action. In the event of a low fuel or battery state, the UAV will automatically execute recovery procedures to reduce the possibility of UAV loss. If necessary, the user may override this function to maintain coverage over the target area or point of interest. The system may recommend the launch of a replacement UAV. The user can also specify to replace the tasked UAV with another airborne UAV. If a replacement UAV arrives before the malfunctioning UAV begins its return to base, the system replaces the malfunctioning UAV with the new UAV. If the malfunctioning UAV must depart before the new UAV arrives, the system calculates a new mission plan to account for fewer airborne UAVs executing the mission.

#### *Recovering the System.*

The user wishes to recover a UAV that has completed or returned from a mission. The user sends recovery commands using the CUSS software. The CD sends mission data to the UAS via the GCH. The UAS processes this data and returns to a specified recovery location. When UAS operations are complete, the user disables and disconnects the system as required, and prepares the UAS for a follow-on mission.

### *Conduct Post Mission Actions.*

After the completion of a mission, the CUSS will be prepared for the next mission. This may include conducting post flight system checks, replacing consumables such as fuel and batteries, and conducting any necessary repair to the UAS or other CUSS components.

### ***Employment Scenarios.***

#### *Surveil a Stationary Target.*

A user wishes to surveil a stationary target. The user creates a mission plan, deploys the CUSS, and prepares the UAVs for flight. Once the mission plan is complete and approved, the plan is transmitted to the UAVs via the GCH. After UAS deployment, the CD interfaces with the UAV autopilots to guide the UAVs to the target location. Upon reaching the target location, the UAVs perform a search, acquire the target, and set up a loiter flight pattern in accordance with the mission plan or as designated by the user. The UAVs maintain surveillance and sensor coverage of the target. At the end of the mission, the UAVs are re-tasked or returned to their designated recovery location.

While over the designated target, the user may change the UAV and sensor parameters to minimize the chance of detection of the UAVs or to obtain better sensor geometry or resolution of the target. These changes can be accomplished either through sensor control commands, UAV flight commands or both. Depending on the type and scope of changes made by the user, a new mission plan may be generated and sent to the UAVs.

### *Surveil a Moving Target.*

A user wishes to identify and/or follow a moving target, such as a vehicle, human on foot, or ship. The user first creates a mission plan and then deploys the CUSS and UAS if not already in use. The CUSS directs the UAVs to the target location and provides position updates of the moving target as they become available. The UAVs transmit sensor data to the user. Upon reaching the specified location, the UAVs perform a search, acquire the target, and set up a loiter flight pattern to provide sensor coverage over the target of interest. The user designates the target on his or her sensor monitoring screen. The UAVs track the designated target and maintain sensor coverage of the target. If the target moves, the UAVs adjust flight paths to maintain coverage. The user attempts to identify the target vehicle based on the target's features, path of motion, and surroundings. At the end of the mission, the UAVs are returned to their previous tasks or recovery location.

This scenario may be entered from another surveillance task. The user monitoring UAV sensor feeds identifies a vehicular target of further interest. The user directs the system to monitor the target. The UAV transitions to a loiter flight pattern around the newly selected target.

The user may change the default loiter distance to minimize the chance of detection of the UAV or to try to obtain better sensor resolution or geometry angles on the target.

If a UAV is too slow to maintain coverage of a moving vehicle, the CUSS alerts the user. The system predicts the location of the moving target based on its last known location, direction of movement, and velocity.

### *Reconnoiter Ahead of a Moving Target.*

A user wishes to maintain surveillance ahead of a moving target or convoy of vehicles. The user creates a mission plan with the CUSS software and this mission plan is uploaded to the UAVs via the GCH. After system deployment, the CUSS directs the UAVs to the designated coverage area where the moving target or convoy is located. The CUSS tracks the moving target through the use of a tracking beacon that transmits current GPS position data. This GPS data is collected by the UAVs and the CUSS monitors the position and speed of the beacon. The system adjusts UAV positioning to provide desired coverage around the beacon in accordance with the mission plan or user input. The UAVs transmit sensor data to users operating the system (in the convoy or at a fixed base). At the end of the mission, the UAVs return to their recovery location.

During the mission, if a user detects a point for further study, the user commands one UAV to focus on that point. The single UAV transitions to a loiter flight plan around the selected point as directed by the user. The CUSS redistributes the coverage ahead of the moving target or convoy among the remaining UAVs. When the user directs the system to stop monitoring the point of interest, the CUSS directs the single UAV back into the original formation and redistributes coverage assignment among the entire formation.

The user may specify a sensor coverage displacement, distance, or time ahead of the moving vehicle for the UAVs to operate. The system continuously computes the proper speed and position for the UAVs to maintain the desired coverage based on the convoy's position and speed.

### *Provide Surveillance of a Series of Waypoints.*

A user wishes to provide surveillance of a series of waypoints, such as a road, route, perimeter, maritime transit lane, or geographic border. The user creates a mission plan by inputting the designated waypoints into the CUSS software. The CUSS then directs the UAVs to their initial waypoints and begins executing the desired mission plan. The system manages the coverage of the UAVs until they are directed to recover.

During the mission, if a user detects a point for further study, the user commands the UAV to focus on that point. The UAV transitions to a loiter flight plan around the designated point. The CUSS redistributes the coverage along the route among the remaining UAVs. When the user directs the system to stop monitoring the target, the CUSS directs the UAV back into formation along the route and redistributes coverage.

### *Conduct a Broad Area Search.*

A user wishes to search a large area. The user creates a mission plan and uploads the mission plan to the UAVs via the GCH. After deployment, the UAVs fly to their first waypoints in the area of interest. The system divides the coverage area and allocates coverage assignments among the available UAVs. The UAVs execute the mission plan and transmit sensor data back to the system operator or other distributed users. The system reports to the users when the entire area has been reconnoitered. At the end of the mission, the UAVs return to their recovery location.

During the mission, if a UAV detects a point for further study, the user directs the corresponding UAV to focus on that point. The UAV transitions to a loiter flight pattern around the selected point of interest. The system redistributes the remaining area to be covered among the remaining UAVs.

The users may change the area of interest during the mission through the CUSS software. If this occurs, the CUSS replans the mission and recalculates the distribution of the coverage among the UAVs.

#### *Conduct a Search for a Target.*

A user wishes to conduct a target search, such as for an enemy vehicle or downed aircrew. The user creates a mission plan and deploys the system. The user inputs the initial search pattern start point, search pattern type (ladder search, expanding square, etc.), and bounds on the search area into the CUSS software. The CUSS creates a mission plan and sends that plan to the UAS via the GCH. Once deployed, the UAVs fly to the initial search start point. The system divides coverage of the search area among the UAS platforms. The UAVs conduct a search of the area and transmit sensor data back to the operator or other distributed users.

During the mission, if a monitor detects a point for further study, the operator directs the corresponding UAV to focus on that point. The UAV transitions to a loiter flight pattern around the selected target. The system redistributes the remaining area to be covered among the remaining UAVs

### **Command Authorities and Relationships**

The CUSS is designed to be operated by tactical users to support mission requirements. These requirements may derive from the needs of the tactical operator or from a higher level of command. To support requirements originating outside the tactical units, the CUSS accepts taskings and amplifying information from higher level command

and control authorities. Once tasked, the tactical operators initiate the tactical mission plan. During mission execution the system returns mission data and status to higher command authorities for the purpose asset tracking, situational awareness, and relay of collected ISR data.

## **Summary**

As combat experience and war-time use of UAVs increases, the DoD is increasingly relying on these platforms to conduct missions previously accomplished by manned systems such as ISR, SAR, and broad area search missions. On today's battlefield, most UAVs operate independently and separately from one another which limits overall terrain coverage and timeliness of data to end users. By effectively combining multiple UAVs into a cooperative formation, COCOMs, tactical warfighters, and other end users will receive better situational awareness, faster mission data, and further increase the variety of mission types UAVs are able to accomplish. The CUSS is designed to facilitate cooperative UAS capabilities by enabling a common, scalable control architecture.



## Appendix C: AV-1 Overview and Summary Information

### Identification

**Name:** Cooperative Unmanned Aerial Surveillance Control System

**Short Name:** Cooperative Unmanned Surveillance System (CUSS)

**Involved Organizations:**

AFRL/RV

AFIT/ENV-GSE: USAF Graduate Systems Engineering program;  
architecture developers

**Date:** The period of development for this architecture was from May 2008 – February 2009.

### Background

Current UAV operational effectiveness and capability is limited to using one airborne platform at a time to conduct an assigned mission. In response to previous research and extensive Joint Capabilities Integration and Development System (JCIDS) analysis, cooperative UASs composed of several UAVs were identified as possible solutions to provide additional ISR capabilities. By developing an integrated cooperative control architecture, UASs can accomplish a wider variety of ISR mission taskings and provide more responsive data to warfighters than is currently possible with singular UAVs.

## **Purpose**

The purpose of this effort is to develop a flexible common architecture for multi-UAV cooperative command and control operations that is scalable from man-packable systems up to larger and longer endurance platforms. This architecture is not specific to any particular type of air vehicle or ground station setup. It is designed to enable users to plan cooperative UAV missions, conduct those missions by directing UAV formations and sensors, and collect, process, and distribute data gathered from the missions.

## **Scope**

The products associated with this conceptual architecture depict a scalable and robust system. During the creation of the prototype system, hardware and software resource constraints limited testing of the conceptual architecture to a maximum of four identical UAVs. This evaluation also investigated the ability to simultaneously control multiple UAVs, gather telemetry and sensor data from multiple UAVs, and utilize separately-developed control algorithms to perform various mission tasks. Areas not fully evaluated or requiring additional research are proposed as risk areas and recommended as future research topics.

## **Time Frame**

First generation deployable cooperative UASs are targeted for delivery within the next three to five years.

## Appendix D: AV-2 Integrated Dictionary

### Introduction

#### *Integrated Dictionary Overview*

The Integrated Dictionary (AV-2) contains definitions of terms used in the given architecture. It consists of textual definitions in the form of a glossary, a repository of architecture data, their taxonomies, and their metadata (i.e., data about architecture data), including metadata for tailored products, associated with the architecture products developed.

#### *Integrated Dictionary Purpose*

The AV-2 enables the set of architecture products to stand alone, allowing them to be read and understood with minimal reference to outside resources. AV-2 is an accompanying reference to other products, and its value lies in unambiguous definitions. The key to long-term interoperability can reside in the accuracy and clarity of these definitions.

#### *Integrated Dictionary Description*

The AV-2 defines terms used in an architecture, but it is more than a simple glossary. Many architectural products have implicit or explicit information in the form of a glossary, a repository of architecture data, their taxonomies, and their metadata. Each labeled item (e.g., icon, box, or connecting line) in the graphical representation should have a corresponding entry in AV-2. Each item from a textual representation of an architecture product also has a corresponding entry in AV-2.

## Integrated Dictionary Content

This table contains the nouns, entities, attributes, relationships, and needlines used in the CUSS architecture.

**Table 7. CUSS AV-2 Integrated Dictionary**

<i>Term</i>	<i>Description</i>	<i>Origin</i>	<i>Destination</i>
A/C Status Interface	<b>Description:</b> This interface passes aircraft telemetry and system status information to the Airborne Control Unit. Telemetry information includes the aircraft position, velocity, and time. System status information can include fuel level, battery voltage, or engine RPM. <b>Type:</b> Interface <b>Views:</b> SV-1		
Accept GPS Receiver Signal	<b>Description:</b> This CUSS Software function interprets data from an external GPS Receiver. The data provides the position, velocity, and time of the CUSS Ground System. These parameters may be used in mission planning (to provide a home location) or having the UAVs follow the Ground System during a mission. <b>Reference:</b> 1.3.10 <b>Views:</b> SV-4, SV-5		
ACM Boundaries	<b>Description:</b> Aircraft Control Measure (ACM) boundaries are the physical operational envelope limits provided by the C2ISR node that the UAS is not allowed to exceed. These could include sovereign borders, kill boxes, Restricted Operating Zones (ROZs), and other limitations imposed to minimize interference with other on-going air or ground operations. <b>Type:</b> ICOM <b>Views:</b> OV-5 ----- <b>Type:</b> Needline <b>Views:</b> OV-2	A-2 ----- C2ISR Node	A1.2 ----- CUSS Node
ACM Restrictions	<b>Description:</b> Airspace Control Measure (ACM) restrictions are established by the C2ISR node or other higher level authorities that restrict the operational flight envelope of the UAV. Examples of restrictions include coordination to enter restricted airspace, mandated use of transit routes, and coordination altitude guidance. <b>Type:</b> ICOM <b>Views:</b> OV-5 ----- <b>Type:</b> Needline <b>Views:</b> OV-2	A-2 ----- C2ISR Node	A1.2 ----- CUSS Node

<i>Term</i>	<i>Description</i>	<i>Origin</i>	<i>Destination</i>
Activity	<p><b>Description:</b> A task or grouping of tasks that provides a specialized capability, service, or product; OV-5 diagrams the most significant task groupings that are in the resources lifecycle.</p> <p><b>Type:</b></p> <p><b>Views:</b></p>		
Air Vehicle	<p><b>Description:</b> The Air Vehicle is the aircraft body that carries the Sensor Package and CUSS airborne hardware. It is not fixed in size or configuration, but refers to any UAV on which the CUSS is installed, including fixed wing, rotorcraft, lighter than air, and gliders. It includes the airframe, control surfaces and mechanisms, propulsion system, fuel, and power system. The Air Vehicle includes a GPS Receiver to determine its position, velocity, and time. It may include organic sensors that are not part of the mission Sensor Package, such as a pitot/static system or temperature sensor. It can include health and status monitoring equipment, such as fuel level, engine RPM, or battery voltage. It may also include non-CUSS communications hardware, such as an ATC transponder. The Air Vehicle is not supplied by the CUSS.</p> <p><b>Type:</b> System Node</p> <p><b>Views:</b> SV-1</p>		
Airborne Antenna Interface	<p><b>Description:</b> This interface transfers waveform data between the Airborne Transceiver and UAV Communications Antenna(s). It operates by means of RF cables.</p> <p><b>Type:</b> System</p> <p><b>Views:</b> SV-1</p>		
Airborne Control Unit	<p><b>Description:</b> The Airborne Control Unit is a package of CUSS hardware and firmware carried by the Air Vehicle that is responsible for controlling the UAV platform and its sensors. This system interfaces with the Airborne Transceiver to send data to and receive data from the ground station and other CUSS UAVs. It provides flight control commands to and receives vehicle status information from the Air Vehicle. It also sends commands to and receives status information from the Sensor Package. The Airborne Control Unit is an integral component of the CUSS.</p> <p><b>Type:</b> System</p> <p><b>Views:</b> SV-1</p>		
Airborne System	<p><b>Description:</b> The Airborne System refers to the collection of CUSS and non-CUSS components co-located in each UAV. There may be multiple instances of the Airborne System (multiple UAVs). It includes the Air Vehicle, Sensor Package, Airborne Control Unit, Airborne Transceiver, and the Communications Antenna.</p> <p><b>Type:</b> System Node</p> <p><b>Views:</b> SV-1</p>		



<i>Term</i>	<i>Description</i>	<i>Origin</i>	<i>Destination</i>
C2ISR	<b>Description:</b> This system node communicates with the CUSS user and Ground System Computing Device to provide tasking, reports, and other command and control information relevant to mission execution. It encompasses all relevant tasking and information organizations such as a platoon leader, battalion headquarters, or Air and Space Operations Center. <b>Type:</b> System Node <b>Views:</b> SV-1		
C2ISR Node	<b>Description:</b> Mechanism that provides mission tasking and direction to system users and receives finished surveillance products from CUSS Operators and users. <b>Type:</b> Mechanism for A-2 <b>Views:</b> OV-2, OV-5	N/A	A-2
Calculated Winds	<b>Description:</b> The CUSS calculates wind speed and direction for each UAV. This is used to refine formation management. <b>Type:</b> ICOM <b>Views:</b> OV-5	A2.4	A2.3
Capture Surveillance Data	<b>Description:</b> In this function, the CUSS Software ensures that all UAS, sensor, and mission data is collected, recorded, and made available for review and manipulation by the CUSS Operator. <b>Reference:</b> 1.3.4 <b>Views:</b> SV-4, SV-5		
Communications Antenna	<b>Description:</b> The Communications Antenna broadcasts and receives electromagnetic communication waves. It is responsible for passing communications and sensor data between each UAV and the Ground System. This includes the antennas at the ground station and on each aircraft. It also includes any additional amplification and filtering hardware, as well as communication relays. The Communications Antennas are not supplied by the CUSS. <b>Type:</b> System <b>Views:</b> SV-1		
Communications Link	<b>Description:</b> The communications link passes data between the UAVs and between the UAVs and the ground station. It is the electromagnetic waves that travel between the airborne and ground antennas. The communications link does not include information from the sensor feeds. <b>Type:</b> Interface <b>Views:</b> SV-1		
Compute Mission Plan	<b>Description:</b> This CUSS Software function describes the computation and creation of a fully executable mission plan. This includes calculations of time, fuel consumption, sensor coverage, and optimized routes. <b>Reference:</b> 1.3.6 <b>Views:</b> SV-4, SV-5		

<i>Term</i>	<i>Description</i>	<i>Origin</i>	<i>Destination</i>
Compute Navigation Solution	<b>Description:</b> This function describes how the Airborne Control Unit calculates the UAV flight route to achieve parameters of the mission plan, desired formation position, and desired sensor coverage. The Airborne Control Unit computes desired aircraft parameters such as airspeed, aircraft orientation, and flight path angle. <b>Reference:</b> 2.1.6 <b>Views:</b> SV-4, SV-5		
Compute Sensor Control Commands	<b>Description:</b> In this function, the CUSS Software generates directives to manage UAV sensors, command sensor track on points of interest, or directly control sensor pointing angles and settings. The CUSS Software then communicates these commands to the UAV sensors through data packets sent to the Ground Transceiver. <b>Reference:</b> 1.3.9 <b>Views:</b> SV-4, SV-5		
Compute Sensor Solution	<b>Description:</b> This function describes how the Airborne Control Unit calculates the correct sensor gimbal angles necessary to keep the point of interest within the sensor field of view. The Airborne Control Unit compares the UAV position and orientation with the coordinates of the point of interest to compute these angles. <b>Reference:</b> 2.1.7 <b>Views:</b> SV-4, SV-5		
Compute UAV Control Commands	<b>Description:</b> In this function, the CUSS Software generates directives to manage the UAV formation, navigate the UAVs, or directly control individual UAVs. The CUSS Software then communicates these commands to the UAVs through data packets sent to the Ground Transceiver. <b>Reference:</b> 1.3.8 <b>Views:</b> SV-4, SV-5		
Computing Device	<b>Description:</b> The Computing Device hosts the CUSS Software and provides interfaces with the Operator, C2ISR, and communications hardware. It includes the processor, electronic storage, one or more display devices, input devices, printing devices, and data ports. The Computing Device can be a laptop or desktop system, and is not supplied by the CUSS. <b>Type:</b> System <b>Views:</b> SV-1		
Computing Device Interface	<b>Description:</b> The Computing Device interface is the mechanism by which the user interacts with the CUSS Software through the Computing Device. This includes standard human/computer interfaces such as a keyboard, mouse, and one or more monitors. It may also include an analog control pad, touch-screen, or other input device. <b>Type:</b> Interface <b>Views:</b> SV-1		



<i>Term</i>	<i>Description</i>	<i>Origin</i>	<i>Destination</i>
Conduct Mission	<b>Description:</b> This function is responsible for tracking the overall execution of the mission. The UAV position, velocity, and system status are combined into a real-time UAV flight status. They are also tracked over time and compared to the mission plan to produce a mission status with regard to accomplishing the mission tasking. <b>Type:</b> Function A2.1 <b>Views:</b> OV-5	A2.1	A2.1
Control Sensors	<b>Description:</b> This function generates commands to control UAV sensor orientation and settings to accomplish the mission. It ensures the UAV sensors are properly oriented to collect data, including tracking a point of interest. This function also monitors sensor health and status during flight operations, and provides a means to adjust the sensor configuration, such as power, zoom, focus, or mode. <b>Type:</b> Function A3 <b>Views:</b> OV-2, OV-5, SV-5	A3	A3
CUSS Node	<b>Description:</b> The CUSS node is the mechanism that enables multiple UAVs to provide cooperative surveillance capability. This node is composed of Ground System components and Airborne System components to enable the effective mission planning, controlling of sensors, and management of UAV platforms and surveillance data collected by the UAS. <b>Type:</b> Mechanism for A0 <b>Views:</b> OV-2, OV-5, SV-1	N/A	A0
CUSS Software	<b>Description:</b> The CUSS Software resides on the Computing Device and provides the necessary capabilities to plan a mission, manage UAVs, control platform sensors, and manage the surveillance data collected by system assets. It is designed to be compatible with a wide range of operating systems and Computing Device hardware configurations. The CUSS Software is an integral component of the CUSS. <b>Type:</b> System <b>Views:</b> SV-1		
Demodulate Communication Data	<b>Description:</b> This function performed by the Airborne Transceiver takes waveform communications data received by the Airborne System Communications Antenna and demodulates that information. The data is then packetized and sent to the Airborne Control Unit. <b>Reference:</b> 2.2.1 <b>Views:</b> SV-4, SV-5		
Demodulate Communication Data from UAVs	<b>Description:</b> This function performed by the Ground Transceiver takes waveform communications data received by the Ground System Communications Antenna and demodulates that information. The data is then packetized and sent to the CUSS Software, via the Computing Device. <b>Reference:</b> 1.2.1 <b>Views:</b> SV-4, SV-5		

<i>Term</i>	<i>Description</i>	<i>Origin</i>	<i>Destination</i>
Demodulate Reference Signal	<b>Description:</b> This function performed by the Airborne Transceiver takes waveform Reference node data received by the Airborne System Communications Antenna and demodulates that information. The data is then packetized and sent to the Airborne Control Unit. <b>Reference:</b> 2.2.2 <b>Views:</b> SV-4, SV-5		
Demodulate Sensor Data from UAVs	<b>Description:</b> This function performed by the Ground Transceiver takes waveform sensor data received by the Ground System Communications Antenna and demodulates that information. The data is then packetized and sent to the CUSS Software, via the Computing Device. <b>Reference:</b> 1.2.2 <b>Views:</b> SV-4, SV-5		
Desired Gimbal Angle	<b>Description:</b> The sensor gimbal angle in the aircraft body reference frame needed to aim the sensor at the selected point of interest. <b>Type:</b> ICOM <b>Views:</b> OV-5	A3.2	A3.3
Environmental Constraints	<b>Description:</b> A set of limitations imposed on the flight area of the UAVs, including restricted airspace, threat areas, or sovereign borders. This is primarily used to dictate navigation routes when generating the mission plan. These constraints may also drive the selection of resources for a specific mission. <b>Type:</b> ICOM <b>Views:</b> OV-5	A1.2	A1.1 A1.4
Environmental Data	<b>Description:</b> The set of specific coordinates defining areas or boundaries of known environmental constraints. <b>Type:</b> ICOM <b>Views:</b> OV-5	A1.3	A1.4
Flight Control Interface	<b>Description:</b> The flight control interface enables communication between the Airborne Control Unit and the Air Vehicle control surfaces and propulsion system. This connection sends commands to move the flight control surfaces or change the throttle setting. <b>Type:</b> Interface <b>Views:</b> SV-1		
Formation Position Error	<b>Description:</b> The difference between the actual and desired formation position for each UAV. The error includes lateral position, altitude, and velocity vector differences. This error is used to navigate the UAV. <b>Type:</b> ICOM <b>Views:</b> OV-5	A2.3	A2.4

<i>Term</i>	<i>Description</i>	<i>Origin</i>	<i>Destination</i>
Generate Control Commands	<b>Description:</b> This function generates signals to the control surfaces and power plant(s) to control aircraft flight. It utilizes UAV flight path angles, position, and velocity to create the control signals required to achieve the proper course, heading and speed in accordance with navigation and user flight commands. <b>Type:</b> Function A2.4 <b>Views:</b> OV-5	A2.4	A2.4
Generate Mission Plan	<b>Description:</b> This function uses the mission resource list, environmental data and mission parameters to create a fully executable mission plan. The combination of these elements is dictated by environmental constraints and mission taskings. This function also produces planning alerts to inform the user of any constraints in the platform or sensor selection that would keep the system from achieving mission objectives. <b>Type:</b> Function A1.4 <b>Views:</b> OV-2, OV-5	A1.4	A1.4
Generate Sensor Commands	<b>Description:</b> This function generates signals sent to the UAV sensor to reposition or reconfigure it. During tracking, desired gimbal angles are compared to measured gimbal angles to generate movement commands. Direct sensor movement commands may also come from user inputs. Other commands such as power, zoom, or mode are controlled by directions from the Manage Sensors function. <b>Type:</b> Function A3.3 <b>Views:</b> OV-5	A3.3	A3.3
Generate Surveillance Product	<b>Description:</b> This function describes the production of final surveillance products at the conclusion of a mission. The CUSS Software provides a tool for the CUSS Operator to manipulate collected data into a synergistic presentation form. <b>Reference:</b> 1.3.5 <b>Views:</b> SV-4, SV-5		
GPS	<b>Description:</b> The GPS node provides the PNT data necessary to calculate position, velocity, and time for the UAVs, ground station, reference node and C2ISR node. It emits electromagnetic GPS signals. <b>Type:</b> System <b>Views:</b> SV-1		
GPS Interface	<b>Description:</b> The GPS interface passes PNT data from the GPS Receiver to the Computing Device. It operates by means of a standard computer data port, such as a USB 2.0 connection. <b>Type:</b> Interface <b>Views:</b> SV-1		
GPS Node	<b>Description:</b> GPS satellite system that is the mechanism for providing precision navigation and timing to ground bases and airborne assets of the CUSS. <b>Type:</b> Mechanism for A-1 <b>Views:</b> OV-2, OV-5, SV-1	N/A	A-1

<b>Term</b>	<b>Description</b>	<b>Origin</b>	<b>Destination</b>
GPS Receiver	<b>Description:</b> The GPS Receiver is a ground-based component that receives GPS signals, computes a position, velocity, and time, and sends the data to the Computing Device. It includes an antenna, receiver, and cable, and is supplied by the unit that owns the system. <b>Type:</b> System <b>Views:</b> SV-1		
GPS Signal	<b>Description:</b> The GPS signal is the electromagnetic waves emitted by GPS satellites. These waves contain data used to calculate position, velocity, and time. <b>Type:</b> Interface <b>Views:</b> SV-1		
Ground Antenna Interface	<b>Description:</b> This interface transfers waveform data between the Ground Transceiver and ground Communications Antenna(s). It operates by means of RF cables. <b>Type:</b> Interface <b>Views:</b> SV-1		
Ground Communications Hardware	<b>Description:</b> The Ground Communications Hardware (GCH) is the Ground System transceiver and Communications Antenna used to pass information between the Ground System and Airborne System assets. <b>Type:</b> <b>Views:</b>		
Ground Control Unit	<b>Description:</b> The Ground Control Unit (GCU) is the combination of all hardware associated with the CUSS Ground System. This includes the Operator, Computing Device, display devices, CUSS Software, Ground Transceiver, GPS Receiver, Communications Antenna, and any associated interfaces between these elements and external nodes or systems. <b>Type:</b> <b>Views:</b>		
Ground Logistics Node	<b>Description:</b> The ground logistics node provides UAV and sensor configuration prior to launch, in addition to maintenance functions for the UAV platforms. Depending on mission profile, the ground logistics node may also launch and recover the UAV platforms, and transfer control with the UAS operator in accordance with the mission plan. <b>Type:</b> Mechanism to A-4 <b>Views:</b> OV-2, OV-5	N/A	A-4
Ground System	<b>Description:</b> The Ground System refers to the collection of CUSS and non-CUSS components co-located on the ground, and used to control airborne assets and produce surveillance information. It includes the Operator, Computing Device, CUSS Software, Ground Transceiver, GPS Receiver, and Communication Antenna. <b>Type:</b> System Node <b>Views:</b> SV-1		

<i>Term</i>	<i>Description</i>	<i>Origin</i>	<i>Destination</i>
Ground Transceiver	<b>Description:</b> This component modulates data packets sent by the CUSS Software and demodulates packets received from the airborne platforms. It can operate over multiple frequencies and receive multiple streams of sensor data. The Ground Transceiver is an integral component of the CUSS. <b>Type:</b> System <b>Views:</b> SV-1		
Ground Transceiver Interface	<b>Description:</b> This interface transfers data between the CUSS Software (via the Computing Device) and the Ground Transceiver. It operates by means of a standard computer data port, such as a USB 2.0 or serial connection. <b>Type:</b> Interface <b>Views:</b> SV-1		
Interface with Airborne Transceiver	<b>Description:</b> This function describes how the Airborne Control Unit communicates with the Airborne Transceiver. The Airborne Control Unit packetizes data for the Ground System and other UAVs, and sends that data to the Airborne Transceiver through a data connection. The Airborne Control Unit also receives packetized Ground System and UAV data from the Airborne Transceiver through the same connection. <b>Reference:</b> 2.1.1 <b>Views:</b> SV-4, SV-5		
Interface with C2ISR	<b>Description:</b> A key function of the system user or Operator is direct and frequent interaction with the C2ISR node during UAS mission planning and mission execution. The user will communicate with the C2ISR node during mission planning to understand any mission specific parameters or constraints and select necessary UAS and sensor assets available to the user. During mission execution, the user may also interface with the C2ISR node to modify the current mission plan and provide surveillance product back to this node for use in future missions. <b>Reference:</b> 1.1.6 <b>Views:</b> SV-4, SV-5		
Interface with Ground Transceiver	<b>Description:</b> This function describes how the CUSS Software communicates with the Ground Transceiver. The CUSS Software packetizes data for the UAVs, and sends that data to the Ground Transceiver through a standard data connection (such as USB 2.0). The CUSS Software also receives packetized UAV and sensor data from the Ground Transceiver through the same connection. <b>Reference:</b> 1.3.2 <b>Views:</b> SV-4, SV-5		

<i>Term</i>	<i>Description</i>	<i>Origin</i>	<i>Destination</i>
Interpret Data	<p><b>Description:</b> This function transforms the real-time or recorded sensor and telemetry data into usable information. Guided by the mission tasking, the user generates flight and sensor commands or mission retaskings based on this information. Target locations and other metadata are created from the sensor and telemetry data.</p> <p><b>Type:</b> Function A4.3 <b>Views:</b> OV-5</p>	A4.3	A4.3
ISR Alert	<p><b>Description:</b> Time critical or real-time ISR data that notifies the user of potential threats to the UAS or target changes. These alerts may require a mission replan dependant on the type of alert.</p> <p><b>Type:</b> ICOM <b>Views:</b> OV-5</p>	A-2	A1.2
	<p>-----</p> <p><b>Type:</b> Needline <b>Views:</b> OV-2</p>	C2ISR Node	CUSS Node
ISR Data	<p><b>Description:</b> ISR data is provided by the C2ISR node and provides a situational picture of the areas the UAS will be operating over. This information is used to identify any potential constraints to the mission plan. ISR data may include threat locations and types, flight hazard (such as towers and cables) locations, and terrain data.</p> <p><b>Type:</b> ICOM <b>Views:</b> OV-5</p>	A-2	A1.2 A1.3
	<p>-----</p> <p><b>Type:</b> Needline <b>Views:</b> OV-2</p>	C2ISR Node	CUSS Node
Manage Formation	<p><b>Description:</b> This function governs the coordination of UAVs with respect to timing, lateral positioning, and altitude. Formation includes any coordinated action among UAVs, regardless of their proximity. For example, the formation could be an equally spaced circle of UAVs around a building, or the distribution of UAVs along a lengthy stretch of road. The function uses data from the mission plan, UAV position/velocity, UAV system status, target location, measured weather data, and wind speeds to determine a desired formation position for each UAV and a formation position error. The formation may be governed by user flight commands.</p> <p><b>Type:</b> Function A2.3 <b>Views:</b> OV-5</p>	A2.3	A2.3
Manage Sensors	<p><b>Description:</b> This function generates sensor management commands to ensure proper operation, safety, and modality of the UAV sensors. Sensor management is controlled in response to weather, user commands, and sensor status updates.</p> <p><b>Type:</b> Function A3.1 <b>Views:</b> OV-5</p>	A3.1	A3.1

<b>Term</b>	<b>Description</b>	<b>Origin</b>	<b>Destination</b>
Manage Surveillance Data	<b>Description:</b> This function encompasses the processing, recording, and playback of collected data, the interpretation of collected data, and the production of an exportable surveillance product for the operator, other system users, or the C2ISR node. <b>Type:</b> Function A4 <b>Views:</b> OV-2, OV-5, SV-5	A4	A4
Manage UAVs	<b>Description:</b> Operational function that is responsible for real-time command and control of UAV flight, monitoring of health and status of UAV assets, deconfliction of operational airspace, and establishing formation spacing and control. <b>Type:</b> Function A2 <b>Views:</b> OV-2, OV-5, SV-5	A2	A2
Manipulate Surveillance Product	<b>Description:</b> In this function, the system Operator directs the production of a finished surveillance product. This includes recording and playing back collected sensor data, gathering metadata, and combining data into a document that can be printed, saved to electronic media, or sent through network connections to the C2ISR node or other system users. <b>Reference:</b> 1.1.5 <b>Views:</b> SV-4, SV-5		
Measured Weather Alert	<b>Description:</b> Measured Weather Alert information is conditions detected by the UAV platform or sensor systems that could affect the performance or safety of the aircraft or sensors, or otherwise impact the mission. Alert information may include high winds, icing, heavy precipitation, or other weather conditions encountered by the UAV. <b>Type:</b> ICOM <b>Views:</b> OV-5 ----- <b>Type:</b> Needline <b>Views:</b> OV-2	A-4  ----- UAV Airframe Node	A3.1  ----- CUSS Node
Measured Weather Data	<b>Description:</b> Information on meteorological conditions collected by organic UAV sensors and sensor payloads. Examples include ambient temperature and pressure, moisture, precipitation detected by radar, winds, and cloud layers. <b>Type:</b> ICOM <b>Views:</b> OV-5 ----- <b>Type:</b> Needline <b>Views:</b> OV-2	A-4  ----- UAV Airframe Node	A2.3 A2.4  ----- CUSS Node

<b>Term</b>	<b>Description</b>	<b>Origin</b>	<b>Destination</b>
Metadata	<b>Description:</b> Usable information extracted from the interpreted sensor and telemetry data. The information describes the context, quality, condition, or characteristics of the data provided by the UAV platforms and sensors. Examples of metadata include target identification, the time an activity was observed, or the number of vehicles in an area. <b>Type:</b> ICOM <b>Views:</b> OV-5	A4.3	A4.4
Mission Data	<b>Description:</b> Mission Data is information provided by the C2ISR node directly relevant to the mission tasking. This data could include timing, coordinates, target descriptions, frequencies, and other information necessary to plan the mission. <b>Type:</b> ICOM <b>Views:</b> OV-5 ----- <b>Type:</b> Needline <b>Views:</b> OV-2	A-2  ----- C2ISR Node	A1.3  ----- CUSS Node
Mission Parameters	<b>Description:</b> The set of data that defines attributes key to accomplishing the mission tasking. This information is used to create an executable mission plan. Examples of this data include target location, desired surveillance duration, search area boundaries, desired revisit time, and desired sensor-to-target line. <b>Type:</b> ICOM <b>Views:</b> OV-5	A1.3	A1.4
Mission Plan	<b>Description:</b> A set of static elements used to direct UAVs and sensors to conduct a surveillance mission. Examples of these elements include waypoint and target locations, altitudes, waypoint commands, timing commands, formation types, and predicted mission metrics. <b>Type:</b> ICOM <b>Views:</b> OV-5	A1.4	A2.1 A2.2 A2.3 A2.4
Mission Resource List	<b>Description:</b> The mission resource list is a set of UAV and sensor assets selected by the user and CUSS to create an executable mission plan. <b>Type:</b> ICOM <b>Views:</b> OV-5	A1.1	A1.4
Mission Status	<b>Description:</b> The current state of the mission being executed with regards to desired objectives. During mission execution, mission status is reported to the C2ISR node and other system users to ensure situational awareness. Mission status includes information such as percent of mission completed, area covered, total number of UAVs operational, or other statistics of interest. <b>Type:</b> ICOM <b>Views:</b> OV-5 ----- <b>Type:</b> Needline <b>Views:</b> OV-2	A2.1  ----- CUSS Node	A-2 A1.1 A4.1  ----- C2ISR Node



<b>Term</b>	<b>Description</b>	<b>Origin</b>	<b>Destination</b>
Mission Tasking	<p><b>Description:</b> The mission tasking includes requirements passed down from the C2ISR node to the CUSS and is used to select the appropriate resources in response to a mission tasking.</p> <p><b>Type:</b> ICOM</p> <p><b>Views:</b> OV-5</p> <p>-----</p> <p><b>Type:</b> Needline</p> <p><b>Views:</b> OV-2</p>	<p>A-2</p> <p>-----</p> <p>C2ISR Node</p>	<p>A1.1</p> <p>A1.3</p> <p>A1.4</p> <p>A2.1</p> <p>A4.2</p> <p>A4.4</p> <p>-----</p> <p>CUSS Node</p>
Mission Weather Alert	<p><b>Description:</b> Detected weather information forwarded by the C2ISR node of conditions that may affect UAS operations. This information could include storm warnings, changes in temperature or cloud cover, and other conditions that may limit sensor or platform performance and safety.</p> <p><b>Type:</b> ICOM</p> <p><b>Views:</b> OV-5</p> <p>-----</p> <p><b>Type:</b> Needline</p> <p><b>Views:</b> OV-2</p>	<p>A-2</p> <p>-----</p> <p>C2ISR Node</p>	<p>A1.2</p> <p>-----</p> <p>CUSS Node</p>
Mission Weather Data	<p><b>Description:</b> Forecasted and observed weather information provided by the C2ISR node that affects UAS mission execution. This information may dictate the type, quantity, and specific capabilities of a platform and sensor chosen for a mission. Mission weather data includes temperature, precipitation, clouds layers, transmissivity, and the freezing level.</p> <p><b>Type:</b> ICOM</p> <p><b>Views:</b> OV-5</p> <p>-----</p> <p><b>Type:</b> Needline</p> <p><b>Views:</b> OV-2</p>	<p>A-2</p> <p>-----</p> <p>C2ISR Node</p>	<p>A1.2</p> <p>-----</p> <p>CUSS Node</p>
Modulate Communication Data	<p><b>Description:</b> This function performed by the Airborne Transceiver takes UAV information provided by the Airborne Control Unit, and modulates that information into a waveform. The waveform data is then sent to the Airborne System Communications Antenna for transmission.</p> <p><b>Reference:</b> 2.2.3</p> <p><b>Views:</b> SV-4, SV-5</p>		
Modulate Communication Data for UAVs	<p><b>Description:</b> This function performed by the Ground Transceiver takes both UAV and sensor commands output by the CUSS Software, via the Computing Device, and modulates that information into a waveform. The waveform data is then sent to the Ground System Communications Antenna for transmission.</p> <p><b>Reference:</b> 1.2.1</p> <p><b>Views:</b> SV-4, SV-5</p>		

<i>Term</i>	<i>Description</i>	<i>Origin</i>	<i>Destination</i>
Modulate Sensor Data for the GCU	<b>Description:</b> This function performed by the Airborne Transceiver takes sensor information provided by the Sensor Package, and modulates that information into a waveform. The waveform data is then sent to the Airborne System Communications Antenna for transmission. <b>Reference:</b> 2.2.4 <b>Views:</b> SV-4, SV-5		
Monitor Mission Execution	<b>Description:</b> This function describes the Operator reviewing collected sensor data and UAV status information to ensure the mission is progressing in accordance with the mission plan. The information is displayed to the Operator via the Computing Device on one or more monitors. <b>Reference:</b> 1.1.4 <b>Views:</b> SV-4, SV-5		
Navigate UAVs	<b>Description:</b> This function generates navigation commands to fly the UAV to the desired position. Navigation may be in relation to a mission plan point, a desired formation position, a reference entity, or a sensor point of interest. User flight commands may dictate UAV navigation. Within this function, each UAVs flight path angle is calculated from CUSS sensors and UAV reported velocity. Also, winds are calculated by comparing the aircraft orientation to its flight path angle. <b>Type:</b> Function A2.4 <b>Views:</b> OV-5	A2.4	A2.4
Navigation Commands	<b>Description:</b> Directions dictating the course and speed of the UAV. Examples include climb to 500 ft, bank left 30 deg, turn to a heading of 180 deg, or accelerate to 25 kts. <b>Type:</b> ICOM <b>Views:</b> OV-5	A2.4	A2.5
Operator	<b>Description:</b> The Operator is the human(s) responsible for controlling the CUSS. The Operator communicates with the C2ISR node and interacts with the Computing Device to mission plan, control the UAVs and sensors, monitor the mission, and produce a surveillance product. The Operator is an integral component of the CUSS. <b>Type:</b> System <b>Views:</b> SV-1		
Perform Airborne Control Functions	<b>Description:</b> This function represents the aggregate of all lower functions performed by the Airborne System. It is the sum of the sub-functions Perform Airborne Control Unit Functions and Perform Airborne Transceiver Functions. <b>Reference:</b> 2. <b>Views:</b> SV-4, SV-5		

<i>Term</i>	<i>Description</i>	<i>Origin</i>	<i>Destination</i>
Perform Airborne Control Unit Functions	<b>Description:</b> This function represents the aggregate of all lower functions performed by the Airborne Control Unit. It is the sum of the sub-functions Interface with Airborne Transceiver, receive Aircraft Status Data, Receive Sensor Status Data, Produce Flight Control Commands, Produce Sensor Control Commands, Compute Navigation Solution and Compute Sensor Solution. <b>Reference:</b> 2.1 <b>Views:</b> SV-4, SV-5		
Perform Airborne Transceiver Function	<b>Description:</b> This function represents the aggregate of all lower functions performed by the Airborne Transceiver. It is the sum of the sub-functions Demodulate Communication Data, Demodulate Reference Signal Data, Modulate Communication Data, Modulate Sensor Data for the GCU, and Transmit and Receive Modulated Airborne Data. <b>Reference:</b> 2.2 <b>Views:</b> SV-4, SV-5		
Perform CUSS Software Functions	<b>Description:</b> This function represents the aggregate of all lower functions performed by the CUSS Software. It is the sum of the sub-functions Provide Operator Interface, Interface with Ground Transceiver, Provide Electronic C2ISR Interface, Capture surveillance Data, Generate Surveillance Product, Compute Mission Plan, Track Mission Status, Compute UAV Control Commands, Compute sensor Control Command, and Accept GPS Receiver Signal. <b>Reference:</b> 1.3 <b>Views:</b> SV-4, SV-5		
Perform Ground Control Functions	<b>Description:</b> This function represents the aggregate of all lower functions performed by the Ground System. It is the sum of the sub-functions Perform Operator Functions, Perform Ground Transceiver Functions and Perform CUSS Software Functions. <b>Reference:</b> 1. <b>Views:</b> SV-1, SV-4, SV-5		
Perform Ground Transceiver Functions	<b>Description:</b> This function represents the aggregate of all lower functions performed by the Ground Transceiver. It is the sum of the sub-functions Modulate Communication Data for UAVs, Demodulate Communication Data from UAVs, Demodulate Sensor Data from UAVs, Transmit and Receive Modulated Ground Data. This function is responsible for passing data between the CUSS Software, via the Computing Device, and the Ground System Communications Antenna. <b>Reference:</b> 1.2 <b>Views:</b> SV-4, SV-5		

<i>Term</i>	<i>Description</i>	<i>Origin</i>	<i>Destination</i>
Perform Operator Functions	<b>Description:</b> This function represents the aggregate of all lower functions performed by the Operator. It is the sum of the sub-functions Provide UAV Control Inputs, Provide Sensor Control Inputs, Provide Mission Planning Inputs, Monitor Mission Execution, Manipulate Surveillance Product, and Interface with C2ISR. <b>Reference:</b> 1.1 <b>Views:</b> SV-1		
Plan Mission	<b>Description:</b> This function enables an operator to produce a mission plan that will be used to direct UAVs and sensors to accomplish a mission tasking. The plan is based on available resources, operational constraints, and specified mission parameters. Once created, this plan is static, but as the mission or systems elements change, a re-plan can occur, establishing a new mission plan. <b>Type:</b> Function A1 <b>Views:</b> OV-2, OV-5, SV-5	A1	A1
Planning Alert	<b>Description:</b> A notification of constraints that potentially impact the ability to accomplish the mission. The alert may trigger selecting new resources or setting new mission parameters to overcome the constraints. An example is an insufficient number of UAVs to maintain the required continuous surveillance duration. <b>Type:</b> ICOM <b>Views:</b> OV-5	A1.4	A1.1 A1.3
PNT Data	<b>Description:</b> Precision radiometric timing data used by various nodes to determine location, time, and velocity. <b>Type:</b> ICOM <b>Views:</b> OV-5  ----- <b>Type:</b> Needleline <b>Views:</b> OV-2	A-1  ----- GPS Node	A-2 A-4 A-5 A1.3 A2.2  ----- UAV Airframe Node, Reference Node, C2ISR Node
Process Data	<b>Description:</b> This function continuously transforms raw data, such as UAV orientation, position, and velocity, sensor gimbal angles, and sensor feeds into usable data. It creates a video display for the user and an associated telemetry data stream. The mission status dictates when this function is started and stopped. <b>Type:</b> Function A4.1 <b>Views:</b> OV-5	A4.1	A4.1

<i>Term</i>	<i>Description</i>	<i>Origin</i>	<i>Destination</i>
Produce Flight Control Commands	<b>Description:</b> In this function, the Airborne Control Unit generates signals for the UAV flight controls and throttle. The Airborne Control Unit translates the calculated navigation commands into the proper flight control deflections and throttle settings to achieve them. <b>Reference:</b> 2.1.4 <b>Views:</b> SV-4, SV-5		
Produce Sensor Control Commands	<b>Description:</b> In this function, the Airborne Control Unit generates signals for the Sensor Package. The Airborne Control Unit translates the desired sensor pointing angles into commands to move the sensor gimbal to achieve them. It also passes on sensor management commands such as changing sensors, changing modes, or zooming the sensor. <b>Reference:</b> 2.1.5 <b>Views:</b> SV-4, SV-5		
Produce Surveillance Product	<b>Description:</b> This function brings together all elements of the collected data to create a completed surveillance product which can be accessed by system users and exported to external systems. Recorded sensor video, derived target locations, and other associated metadata is combined in accordance with the objectives of the mission tasking. <b>Type:</b> Function A4.4 <b>Views:</b> OV-5	A4.4	A4.4
Provide C2ISR	<b>Description:</b> Function that generates and disseminates ISR mission taskings, relevant mission data, and associated guidance. The function uses real-time mission updates and collected data from UASs to update C2ISR data and taskings for subsequent missions. <b>Type:</b> Function A-2 <b>Views:</b> OV-2, OV-5	A-2	A-2
Provide Electronic C2ISR Interface	<b>Description:</b> In this function, the CUSS Software communicates with the C2ISR node via the C2 Link. The C2ISR node sends guidance and data used to mission plan and conduct the surveillance mission. The CUSS Software forwards surveillance data and mission status information back to the C2ISR node through the interface as well. <b>Reference:</b> 1.3.3 <b>Views:</b> SV-4, SV-5		
Provide Mission Planning Inputs	<b>Description:</b> In this function, the Operator provides data and commands to the CUSS Software via the Computing Device that initiate and direct the mission planning process. These inputs are used to select resources, and set mission constraints and parameters. The inputs from the Operator may be based on the interpretation of collected data. <b>Reference:</b> 1.1.3 <b>Views:</b> SV-4, SV-5		

<i>Term</i>	<i>Description</i>	<i>Origin</i>	<i>Destination</i>
Provide Operator Interface	<b>Description:</b> In this function, the CUSS Software provides an effective user interface that enables all system functions from mission planning, UAS management, sensor control, and the management of surveillance data. The interface includes displaying information to the Operator on one or more monitors, and receiving information from the Operator through input devices such as a keyboard, mouse, or analog control pad. <b>Reference:</b> 1.3.1 <b>Views:</b> SV-4, SV-5		
Provide PNT	<b>Description:</b> The function of providing precision radiometric timing data to UAV platforms, the CUSS and reference nodes for the purposes of calculating navigation solutions and time keeping. <b>Type:</b> Function A-1 <b>Views:</b> OV-2, OV-5	A-1	A-1
Provide Reference Location	<b>Description:</b> This function provides the geolocated coordinates of the reference source by using PNT data provided by the GPS node. <b>Type:</b> Function A-5 <b>Views:</b> OV-2, OV-5	A-5	A-5
Provide Sensor Control Inputs	<b>Description:</b> In this function, the Operator provides data and commands to the CUSS Software via the Computing Device that control the behavior of the UAV sensors. Based on these inputs, the CUSS can generate control commands that enable effective health and status management of the sensor systems and pointing commands, including tracking a point of interest. The inputs from the Operator may be based on the interpretation of collected data. <b>Reference:</b> 1.1.2 <b>Views:</b> SV-4, SV-5		
Provide Surveillance	<b>Description:</b> The provide surveillance function is the primary purpose of the CUSS. It includes all aspects of planning surveillance missions, managing the tasked UAVs, controlling available sensors, and producing an intelligence product. <b>Type:</b> Function A0 <b>Views:</b> OV-2, OV-5, SV-1	A0	A0
Provide Surveillance Platform	<b>Description:</b> This function provides the physical unmanned aerial platform and onboard sensor(s) as part of the UAS. It moves the sensors through the air via propulsion and flight surfaces controlled by the CUSS. It is responsible for reporting the UAV position and velocity to the CUSS. It also includes the means to launch, recover, and service the aircraft. <b>Type:</b> Function A-4 <b>Views:</b> OV-2, OV-5	A-4	A-4

<b>Term</b>	<b>Description</b>	<b>Origin</b>	<b>Destination</b>
Provide Targets	<b>Description:</b> The function of providing targets that an UAS is assigned to locate in accordance with the mission plan. <b>Type:</b> Function A-3 <b>Views:</b> OV-2, OV-5	A-3	A-3
Provide UAV Control Inputs	<b>Description:</b> In this function, the Operator provides data and commands to the CUSS Software via the Computing Device that control the behavior of the UAVs. Based on these inputs, the CUSS can generate control commands that enable the tracking of a reference point, management of the UAV formation, or navigation of the UAVs. The inputs from the Operator may be based on the interpretation of collected data. <b>Reference:</b> 1.1.1 <b>Views:</b> SV-4, SV-5		
Receive Aircraft Status Data	<b>Description:</b> This function describes how the Airborne Control Unit continuously collects information from the Air Vehicle. This data is used by the Airborne Control unit to navigate the UAV and generate commands for the flight controls. It is also passed on to the Ground System for use in managing the formation and monitoring the mission. <b>Reference:</b> 2.1.2 <b>Views:</b> SV-4, SV-5		
Receive Sensor Status Data	<b>Description:</b> This function describes how the Airborne Control Unit continuously collects information from the Sensor Package. This data is used directly by the Airborne Control Unit and passed on to the Ground System. It is used to manage and control the sensors, as well as extract surveillance data (from the sensor pointing angles, for example). <b>Reference:</b> 2.1.3 <b>Views:</b> SV-4, SV-5		
Record and Playback Data	<b>Description:</b> This function enables system users to store and retrieve processed data for later interpretation and creation of a finished surveillance product. The mission tasking may dictate which information is recorded and retrieved. <b>Type:</b> Function A4.2 <b>Views:</b> OV-5	A4.2	A4.2
Record Telemetry	<b>Description:</b> Processed information and statistics associated with the sensor data that has been stored by the system. It can be retrieved and interpreted or used in the creation of a finished surveillance product. <b>Type:</b> ICOM <b>Views:</b> OV-5	A4.3	A4.3
Recorded Video	<b>Description:</b> Processed UAV sensor data that has been stored by the system. It can be retrieved and interpreted or used in the creation of a finished surveillance product. <b>Type:</b> ICOM <b>Views:</b> OV-5	A4.2	A4.3 A4.4

<i>Term</i>	<i>Description</i>	<i>Origin</i>	<i>Destination</i>
Reference	<b>Description:</b> This system node is able to transmit a reference signal that can be received by the UAV Communications Antenna. This signal is used to relay the reference node's position and velocity. <b>Type:</b> System Node <b>Views:</b> SV-1		
Reference Behavior	<b>Description:</b> The physical behavior of a reference beacon or object that the CUSS must locate, track and follow in accordance with the mission plan. This behavior is a product of the entity (person, vehicle, building) upon which the beacon is located. <b>Type:</b> Control for A-5 <b>Views:</b> OV-2, OV-5	N/A	A-5
Reference Node	<b>Description:</b> An entity that carries a reference beacon which emits a signal that can be tracked by the CUSS in accordance with the mission plan or user direction. <b>Type:</b> Mechanism for A-5 <b>Views:</b> OV-2, OV-5, SV-1	N/A	A-5
Reference Position/Velocity	<b>Description:</b> This is the actual location and velocity vector of an entity being tracked by the CUSS. <b>Type:</b> ICOM <b>Views:</b> OV-5	A2.2	A2.4
Reference Signal	<b>Description:</b> The reference signal is an electromagnetic wave transmitted by the reference node and received by the UAV Communications Antenna. It contains data on the current position and velocity of the reference node. <b>Type:</b> Interface <b>Views:</b> SV-1		
Reference Tracking Signal	<b>Description:</b> A signal provided by the reference node that the CUSS can receive and track. From this signal, the CUSS can obtain the position and velocity of the reference object, and track this beacon in accordance with the mission plan. <b>Type:</b> ICOM <b>Views:</b> OV-5 ----- <b>Type:</b> Needle <b>Views:</b> OV-2	A-5  ----- Reference Node	A2.2  ----- CUSS Node
Select Resources	<b>Description:</b> This function enables the user to select from available resources the assets that will be used to create an executable mission plan. The UAV and sensor assets may be on the ground or airborne. Selection of the resources is dictated by the mission status, mission tasking, user re-tasking inputs, planning alerts, and environmental constraints. The user selects the resources necessary to execute the mission tasking, and a mission resource list is generated for the mission plan. <b>Type:</b> Function A1.1 <b>Views:</b> OV-5	A1.1	A1.1



<i>Term</i>	<i>Description</i>	<i>Origin</i>	<i>Destination</i>
Sensor Control Interface	<b>Description:</b> The sensor control interface is a standardized input/output connection that enables a variety of sensors to interact with the Airborne Control Unit. Through this interface, the CUSS can control sensor functions, such as gimbal movement, zoom, or sensor switching. It also receives sensor status information, such as the gimbal angles, zoom level, or mode. <b>Type:</b> Interface <b>Views:</b> SV-1		
Sensor Data Feed Interface	<b>Description:</b> The sensor data feed interface is a standardized input/output connection that enables collected sensor information to be sent to the Airborne Transceiver. <b>Type:</b> Interface <b>Views:</b> SV-1		
Sensor Data Link	<b>Description:</b> The sensor data link passes sensor feeds from the UAVs to the ground station. It is the electromagnetic waves that travel from the airborne antennas to the ground antenna(s). <b>Type:</b> Interface <b>Views:</b> SV-1		
Sensor Gimbal Angles	<b>Description:</b> The pointing angles of the sensor(s) in relation to the aircraft body frame of reference. <b>Type:</b> ICOM <b>Views:</b> OV-5 ----- <b>Type:</b> Needline <b>Views:</b> OV-2	A-4  ----- UAV Sensor Node	A3.2 A3.3 A4.1  ----- CUSS Node
Sensor Management Commands	<b>Description:</b> Directions to ensure proper operation, safety, and modality of the UAV sensors. Examples include turning on/off, zooming in/out, switching between sensors, or changing modes. <b>Type:</b> ICOM <b>Views:</b> OV-5	A3.1	A3.3
Sensor Package	<b>Description:</b> The Sensor Package is the collection asset(s) carried by the UAV platform. It may be fixed to the Air Vehicle or removable, but it does not include organic Air Vehicle sensors such as a pitot/static system. The sensor package transmits a collected data stream. The Sensor Package is not supplied by the CUSS. <b>Type:</b> System Node <b>Views:</b> SV-1		

<b>Term</b>	<b>Description</b>	<b>Origin</b>	<b>Destination</b>
Sensor Status	<p><b>Description:</b> The sensor status provides all necessary health and status and information for each sensor onboard the UAV. This information includes sensor type, mode, voltage, resolution, temperature, faults, limitations, and other information necessary for the CUSS or user to manage the operation of airborne sensors.</p> <p><b>Type:</b> ICOM <b>Views:</b> OV-5</p> <p>-----</p> <p><b>Type:</b> Needline <b>Views:</b> OV-2</p>	<p>A-4</p> <p>-----</p> <p>UAV Sensor Node</p>	<p>A3.1</p> <p>-----</p> <p>CUSS Node</p>
Sensor Tracking Error	<p><b>Description:</b> A measurement of the difference between the desired and actual sensor orientation when tracking a point of interest. This is used to position the UAV for optimized surveillance collection.</p> <p><b>Type:</b> ICOM <b>Views:</b> OV-5</p>	A3.2	A2.4
Set Constraints	<p><b>Description:</b> This function uses weather data, ACMs, and ISR data to generate the boundaries and limitations the UAVs are allowed to operate within.</p> <p><b>Type:</b> Function A1.2 <b>Views:</b> OV-5</p>	A1.2	A1.2
Set Mission Parameters	<p><b>Description:</b> This function uses ISR data, known target locations, and relevant mission data to generate a set of mission parameters used to generate the mission plan. The selection of mission parameters is dictated by mission taskings, user retaskings, and planning alerts. PNT data is used to calculate the CUSS home location, which may be used as a mission parameter.</p> <p><b>Type:</b> Function A1.3 <b>Views:</b> OV-5</p>	A1.3	A1.3
Space Component Guidance and Tasking	<p><b>Description:</b> Context entity that provides the resources, oversight, and management of the GPS satellite constellation.</p> <p><b>Type:</b> Control for A-1 <b>Views:</b> OV-5</p>	N/A	A-1
Surveillance Product	<p><b>Description:</b> Fully processed and interpreted data becomes a surveillance product that is sent to the C2ISR node. This data then becomes available to other users, and may provide the basis for future mission taskings or surveillance requirements.</p> <p><b>Type:</b> ICOM <b>Views:</b> OV-5</p> <p>-----</p> <p><b>Type:</b> Needline <b>Views:</b> OV-2</p>	<p>A4.4</p> <p>-----</p> <p>CUSS Node</p>	<p>A-2</p> <p>-----</p> <p>C2ISR Node</p>

<b>Term</b>	<b>Description</b>	<b>Origin</b>	<b>Destination</b>
Target Location	<b>Description:</b> A geolocated position of a point of interest derived from collected sensor data. The position is calculated from the designated location on the sensor display, UAV position, sensor pointing angle, and any ranging or topographical data. Target location information can be used to plan a mission or be tracked by the UAVs and sensors. <b>Type:</b> ICOM <b>Views:</b> OV-5	A4.3	A1.3 A2.3 A2.4 A3.2 A4.4
Target Physical Characteristics	<b>Description:</b> The physical characteristics associated with a target such as size, shape, speed, color, and radar signature. <b>Type:</b> ICOM <b>Views:</b> OV-5 ----- <b>Type:</b> Needleline <b>Views:</b> OV-2	A-3  ----- Target Node	A-2 A-4  ----- UAV Sensor Node, C2ISR Node
Targets Behavior	<b>Description:</b> Control attribute of the Provide Targets function that affects the location and characteristics of system targets. <b>Type:</b> Control for A-3 <b>Views:</b> OV-5	N/A	A-3
Targets Node	<b>Description:</b> Physical entity the UAS is assigned to locate in accordance with the mission plan. <b>Type:</b> Mechanism for A-3 <b>Views:</b> OV-2, OV-5	N/A	A-3
Telemetry Data	<b>Description:</b> This includes all of the collected information and statistics associated with the raw sensor stream. It may include information such as time, UAV position, sensor pointing angles, temperature, or other metric of interest. It can be recorded and played back with the associated video, and can be interpreted to extract additional information such as target location. <b>Type:</b> ICOM <b>Views:</b> OV-5	A4.1	A4.2 A4.3
Track Mission Status	<b>Description:</b> This CUSS Software function monitors the conduct of a mission over time. Parameters and statistics such as UAV locations, surveillance coverage time, and percentage of area covered are tracked. This information is used to guide the conduct of the current mission and may be used to replan a mission if required. <b>Reference:</b> 1.3.7 <b>Views:</b> SV-4, SV-5		

<b>Term</b>	<b>Description</b>	<b>Origin</b>	<b>Destination</b>
Track POI	<b>Description:</b> This function enables the system to track a specific location in the sensor field of view. The tracking location is designated from user commands on the video display or from target location coordinates. This data along with the UAV position, velocity, and flight path angle is used to generate a desired gimbal angle to aim the sensor at the point of interest. <b>Type:</b> Function A3.2 <b>Views:</b> OV-5	A3.2	A3.2
Track Reference Point	<b>Description:</b> This function is responsible for tracking a stationary or mobile entity to which the UAVs will maneuver in relation. External entities are tracked via the reference tracking signal. The CUSS GCS can track itself via received PNT data. Control of which entity to track and when is provided by user flight commands. This function also produces the position and velocity of the entity being tracked. <b>Type:</b> Function A2.2 <b>Views:</b> OV-5	A2.2	A2.2
Transmit and Receive Modulated Airborne Data	<b>Description:</b> This function describes how the Airborne Transceiver sends and collects waveform data to and from the Airborne System Communications Antenna. <b>Reference:</b> 2.2.5 <b>Views:</b> SV-4, SV-5		
Transmit and Receive Modulated Ground Data	<b>Description:</b> This function describes how the Ground Transceiver sends and collects waveform data to and from the Ground System Communications Antenna. <b>Reference:</b> 1.2.2 <b>Views:</b> SV-4, SV-5		
UAV Airframe Node	<b>Description:</b> The UAV airframe node includes the physical UAV platforms used to accomplish the mission plan. This node does not include Sensor Packages or CUSS hardware. <b>Type:</b> Mechanism for A-4 <b>Views:</b> OV-2, OV-5	N/A	A-4
UAV Control Commands	<b>Description:</b> These are the control surface and propulsion commands sent to the UAV from the CUSS to produce a desired airspeed and flight path orientation in accordance with the mission plan or user direction. <b>Type:</b> ICOM <b>Views:</b> OV-2, OV-5	A2.5	A-4

<b>Term</b>	<b>Description</b>	<b>Origin</b>	<b>Destination</b>
UAV Flight Status	<p><b>Description:</b> A continuously updated set of data describing the state of each UAV currently being utilized by the system. This data includes position, altitude, velocity, fuel state, health status, and executing command (e.g. "En-route to Waypoint 2" or "Following target"). The information is used when creating a mission plan involving assets currently in use and for providing the C2ISR node with situational awareness on CUSS assets.</p> <p><b>Type:</b> ICOM <b>Views:</b> OV-5</p> <p>-----</p> <p><b>Type:</b> Needline <b>Views:</b> OV-2</p>	<p>A2.1</p> <p>-----</p> <p>CUSS Node</p>	<p>A-2 A1.1</p> <p>-----</p> <p>C2ISR Node</p>
UAV Orientation	<p><b>Description:</b> The orientation of the UAV in relation to the local horizon - heading, pitch and roll angle. This information is used to generate updated control commands, navigation commands, and sensor commands.</p> <p><b>Type:</b> ICOM <b>Views:</b> OV-5</p>	A2.4	A2.5 A3.2 A4.1
UAV Position/ Velocity	<p><b>Description:</b> Current and continuously updated UAV position and velocity information that is derived from GPS or other sources sent from the aircraft to the CUSS.</p> <p><b>Type:</b> ICOM <b>Views:</b> OV-5</p> <p>-----</p> <p><b>Type:</b> Needline <b>Views:</b> OV-2</p>	<p>A-4</p> <p>-----</p> <p>UAV Airframe Node</p>	<p>A2.1 A2.3 A2.4 A2.5 A3.2 A4.1</p> <p>-----</p> <p>CUSS Node</p>
UAV Sensor Commands	<p><b>Description:</b> These are the commands sent from the CUSS to the UAV sensors to direct the gimbal angle, turn on/off, zoom in/out or perform other functions in accordance with the mission plan or user direction.</p> <p><b>Type:</b> ICOM <b>Views:</b> OV-5</p> <p>-----</p> <p><b>Type:</b> Needline <b>Views:</b> OV-2</p>	<p>A3.3</p> <p>-----</p> <p>CUSS Node</p>	<p>A-4</p> <p>-----</p> <p>UAV Sensor Node</p>
UAV Sensor Feed	<p><b>Description:</b> The sensor feed data is the raw bit stream collected by the sensor and transmitted to the CUSS for interpretation and production of the final surveillance product.</p> <p><b>Type:</b> ICOM <b>Views:</b> OV-5</p> <p>-----</p> <p><b>Type:</b> Needline <b>Views:</b> OV-2</p>	<p>A-4</p> <p>-----</p> <p>UAV Sensor Node</p>	<p>A4.1</p> <p>-----</p> <p>CUSS Node</p>

<b>Term</b>	<b>Description</b>	<b>Origin</b>	<b>Destination</b>
UAV Sensor Node	<b>Description:</b> The UAV sensor node is the physical sensor assets carried by UAVs dependent on the mission tasking. <b>Type:</b> Mechanism for A-4 <b>Views:</b> OV-2, OV-5	N/A	A-4
UAV System Status	<b>Description:</b> UAV System Status is information about resident UAV systems monitored for proper operation. This includes fuel level, voltages, temperatures, pressures, revolutions, faults, and communication throughput. <b>Type:</b> ICOM <b>Views:</b> OV-5  ----- <b>Type:</b> Needline <b>Views:</b> OV-2	A-4  ----- UAV Airframe Node	A2.1 A2.3  ----- CUSS Node
User Flight Commands	<b>Description:</b> Directives from the operator to control the UAVs. Examples include flight control surface, altitude, airspeed, navigation, formation, tracking, and mode commands. <b>Type:</b> ICOM <b>Views:</b> OV-5	A4.3	A2.2 A2.3 A2.4 A2.5
User Retasking	<b>Description:</b> Directives from the operator to change the mission plan based on interpretation of collected data. For example, the CUSS user can retask system assets if an object or target of interest is identified. This change may require new resources to provide the collection desired. <b>Type:</b> ICOM <b>Views:</b> OV-5	A4.3	A1.1 A1.3
User Sensor Commands	<b>Description:</b> Directives from the operator to control the sensors. Examples include slew, track, zoom, and mode commands, as well as sensor selection. <b>Type:</b> ICOM <b>Views:</b> OV-5	A4.3	A3.1 A3.2 A3.3
Video Display	<b>Description:</b> The video display is the processed UAV sensor data. It can be displayed to the operator or other system users, recorded and played back, used to control sensors, used to designate targets, and combined with other information to construct a finished surveillance product. <b>Type:</b> ICOM <b>Views:</b> OV-5	A4.1	A3.2 A4.2 A4.3

## Appendix E: CUSS OV-1 Operational Concept

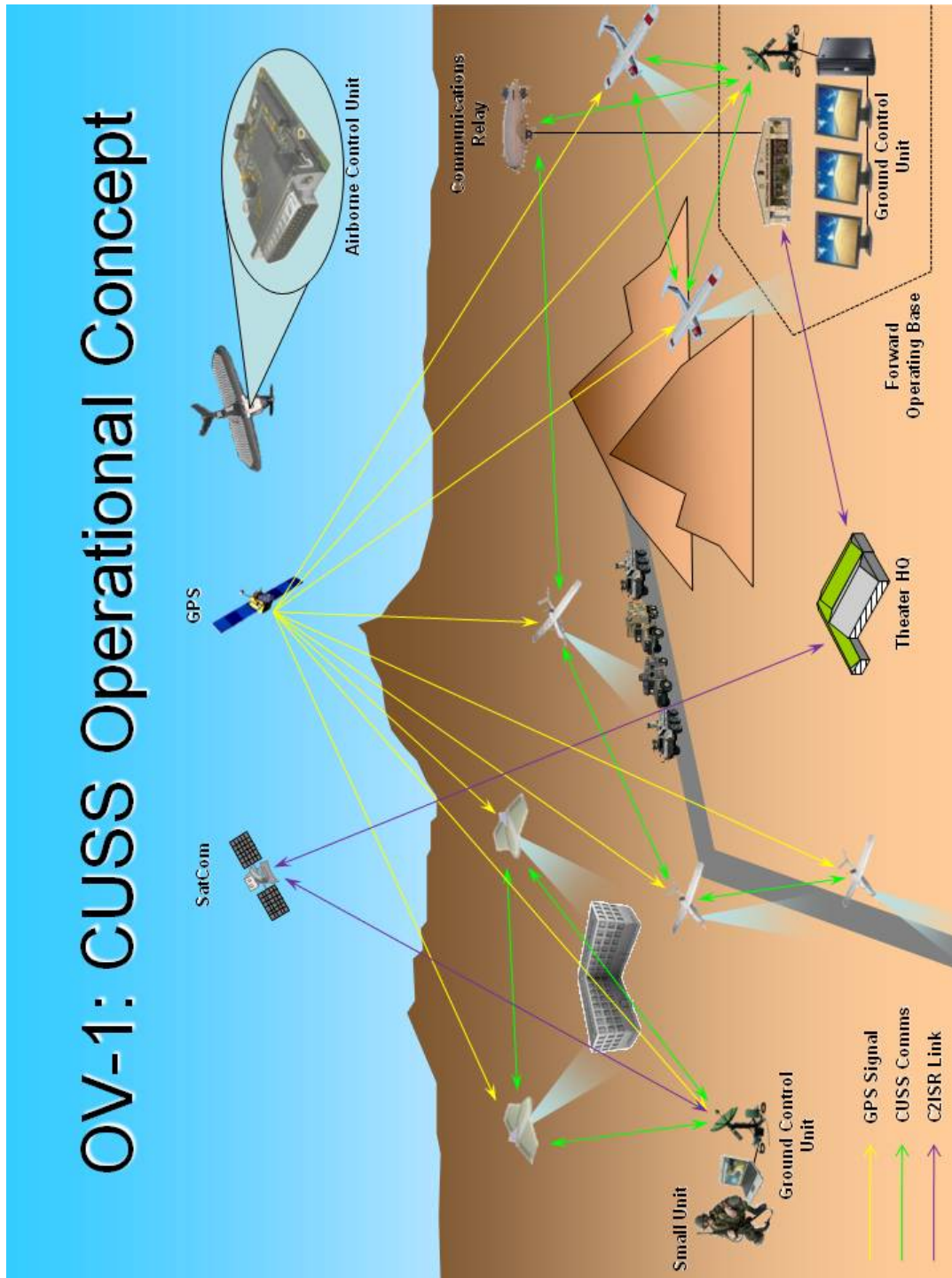

Figure 55. CUSS OV-1 Operational Concept

## Appendix F: CUSS OV-2 Operational Node Connectivity Description

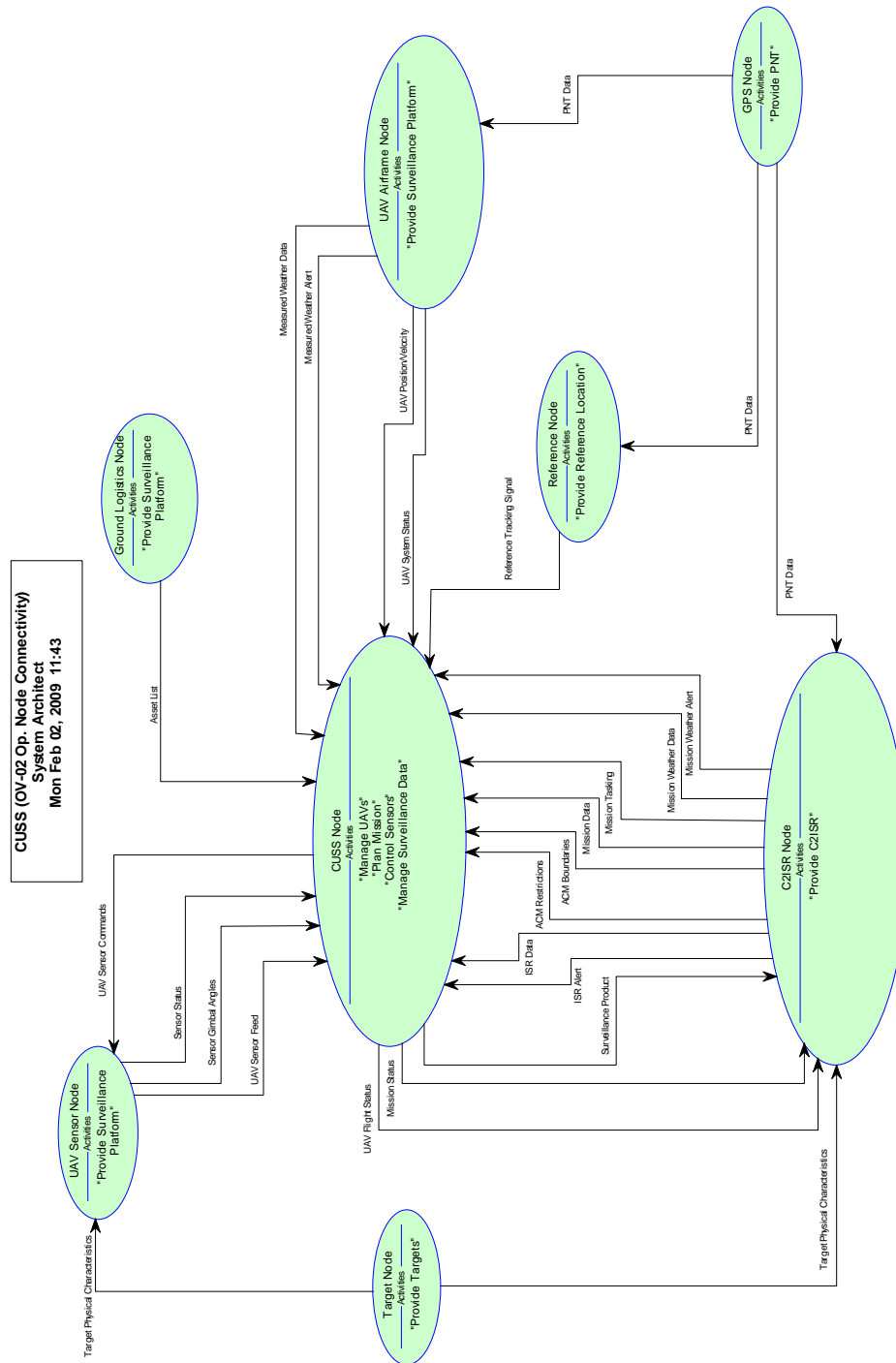

Figure 56. CUSS OV-2 Operational Node Connectivity Description



## Appendix G: CUSS OV-5 Operational Activity Model

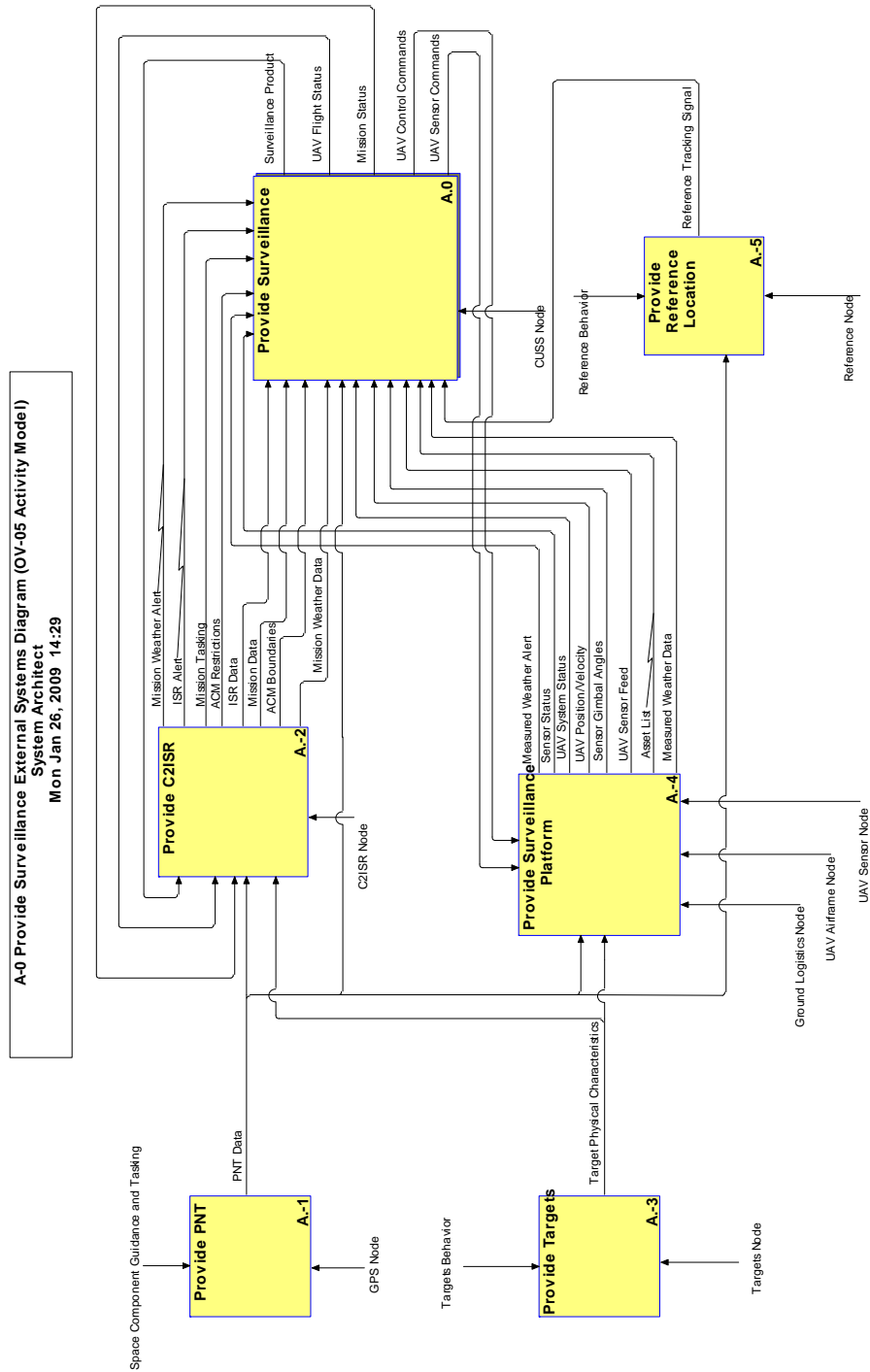
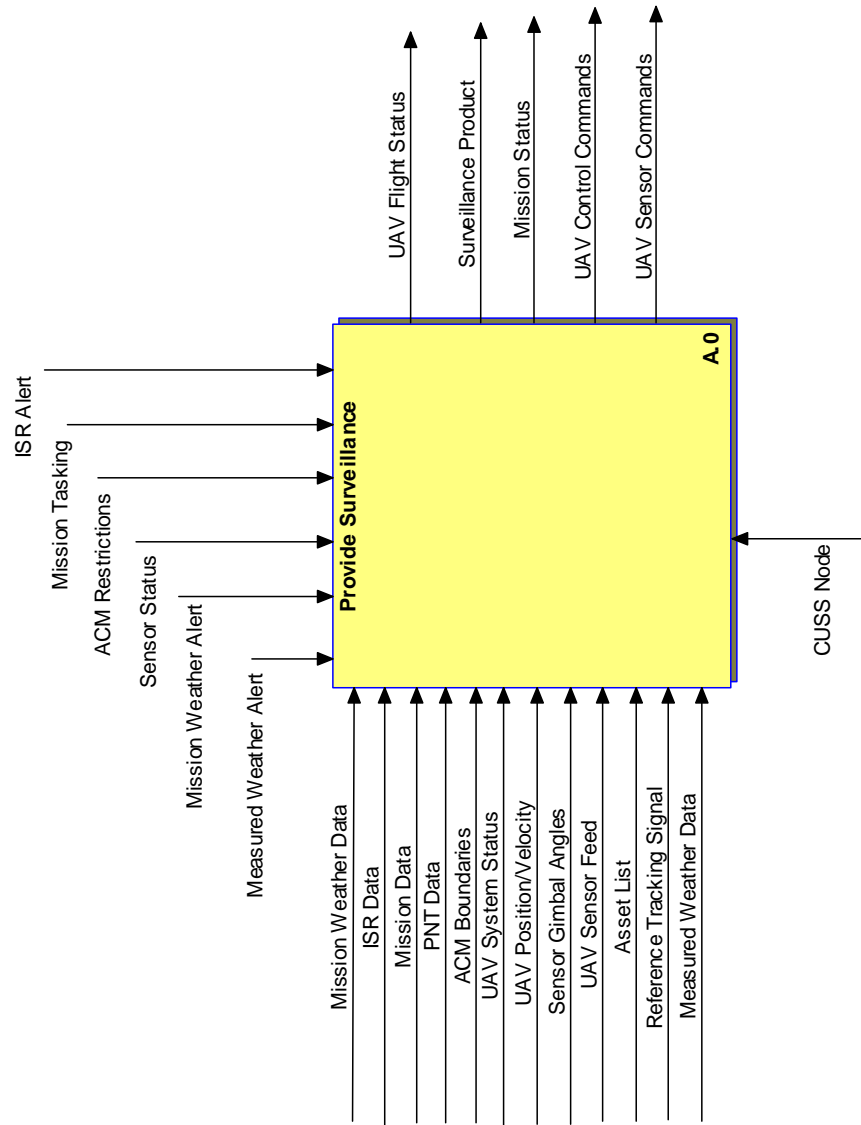

Figure 57. CUSS OV-5 A-0 External Systems Diagram

**A0 Provide Surveillance Context Diagram (OV-05 Activity Model)**  
**System Architect**  
**Mon Jan 26, 2009 14:19**



**Figure 58. CUSS OV-5 A0 Context Diagram**

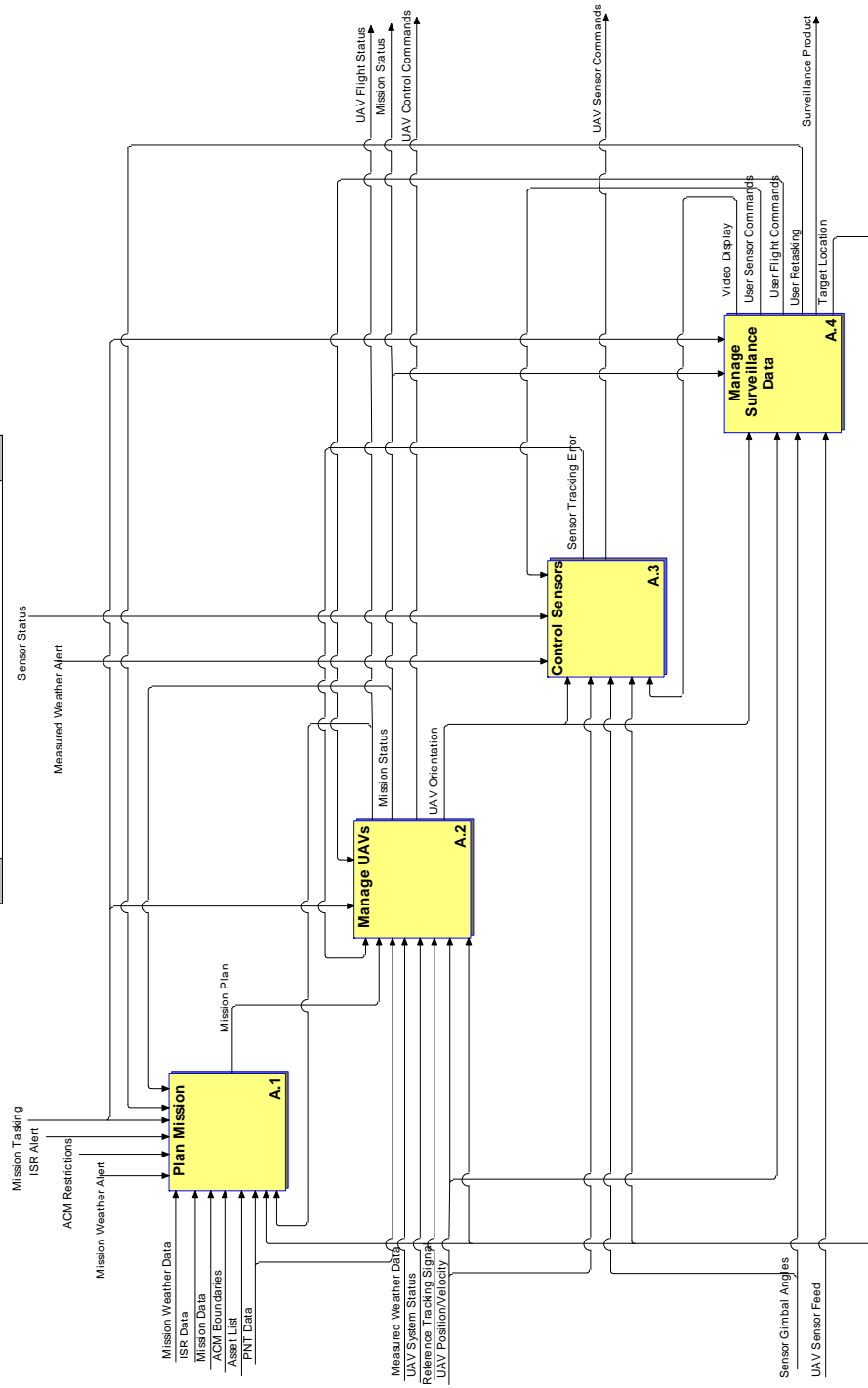
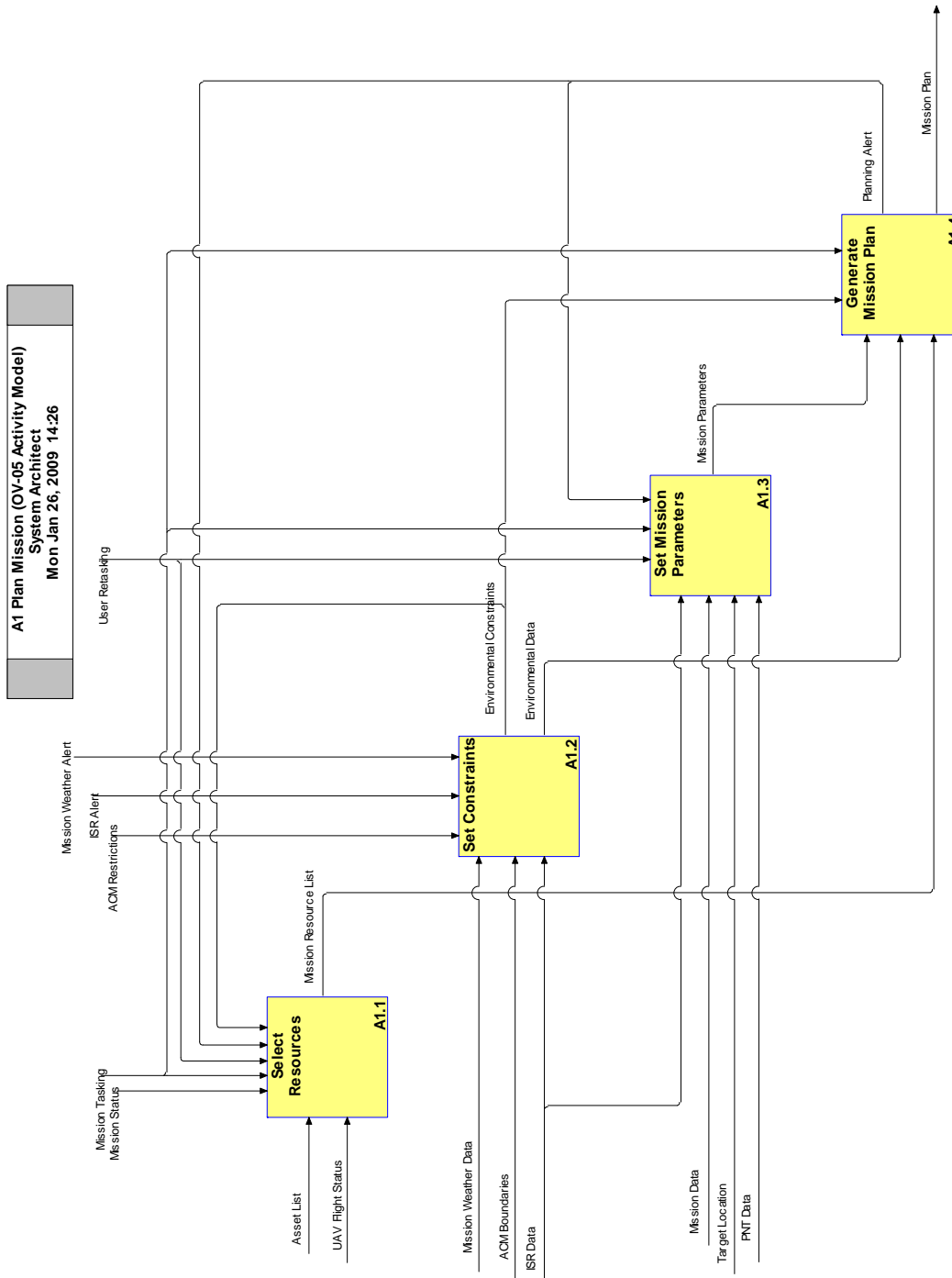
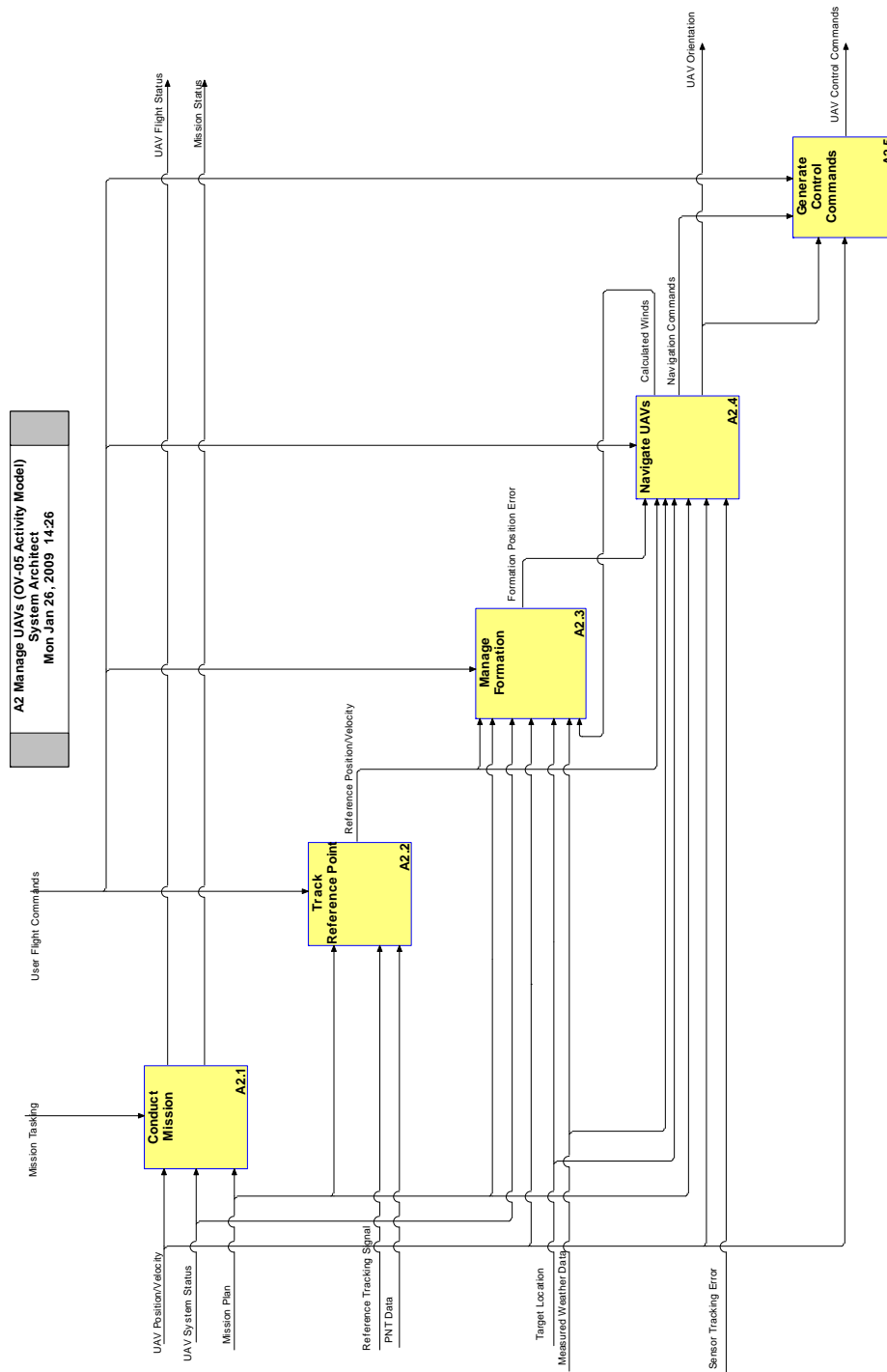

Figure 59. CUSS OV-5 A0 Provide Surveillance



**Figure 60. CUSS OV-5 A1 Plan Mission**



**Figure 61. CUSS OV-5 A2 Manage UAVs**

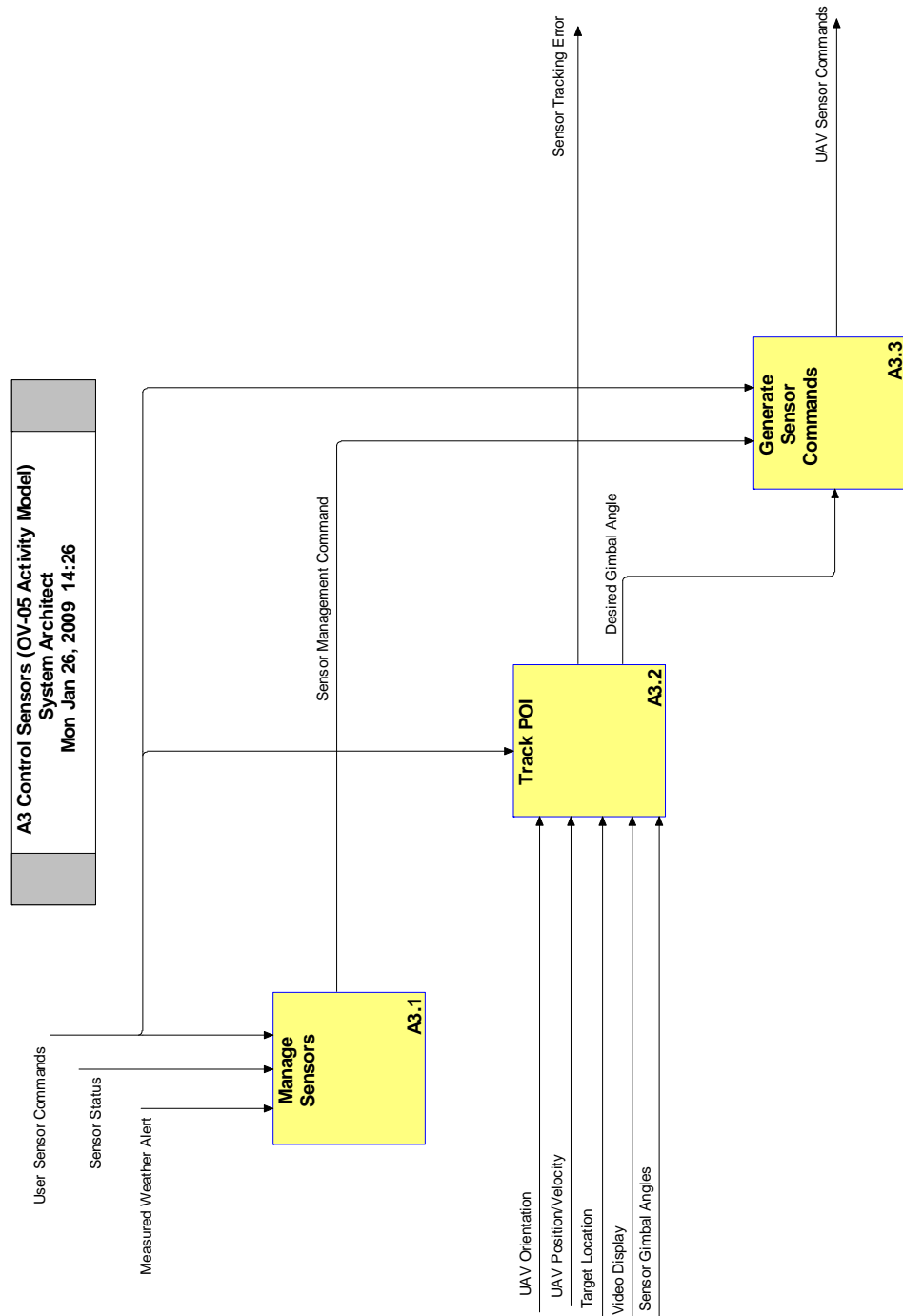
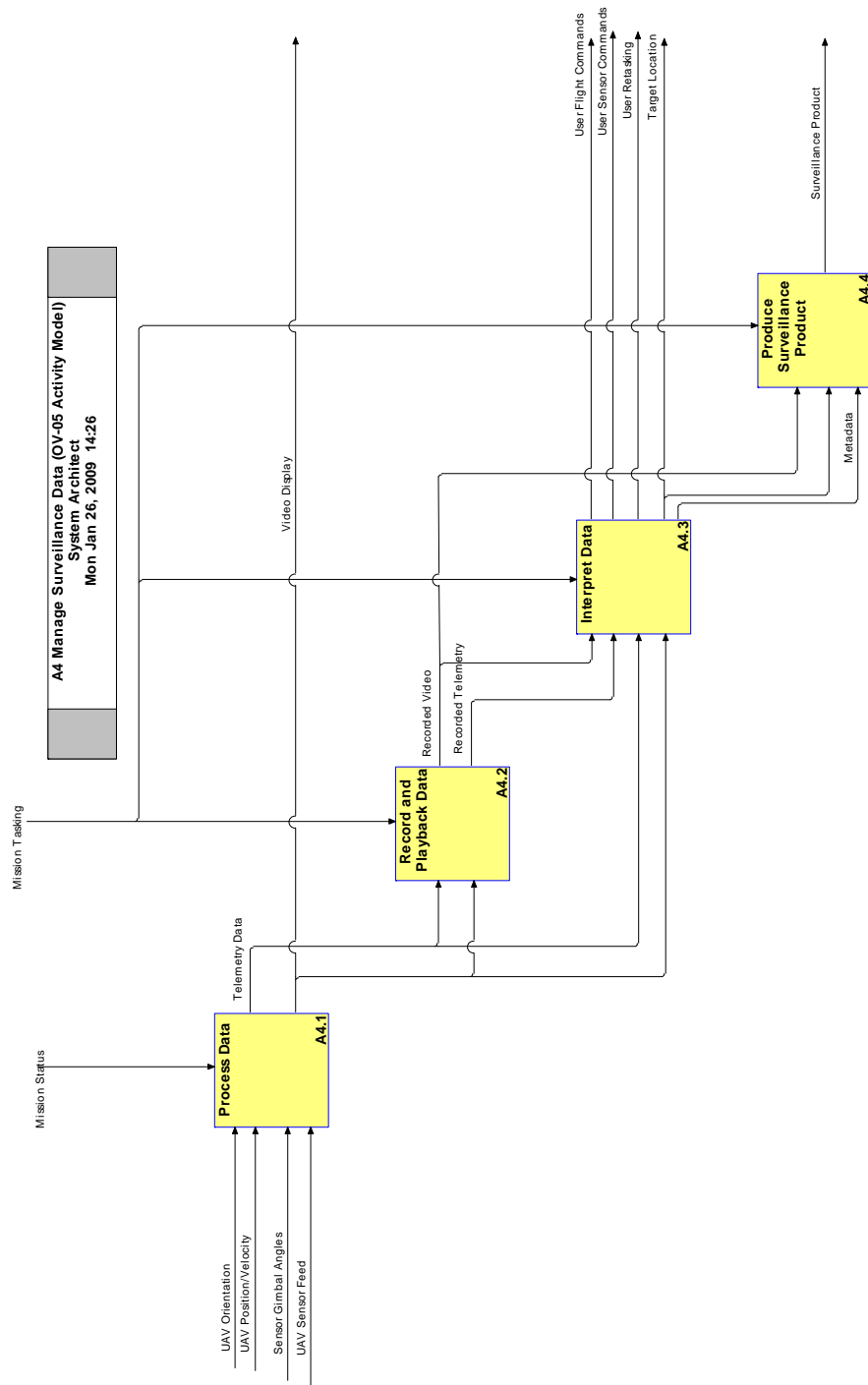

Figure 62. CUSS OV-5 A3 Control Sensors



**Figure 63. CUSS OV-5 A4 Manage Surveillance Data**

## Appendix H: CUSS SV-1 System Interface Description

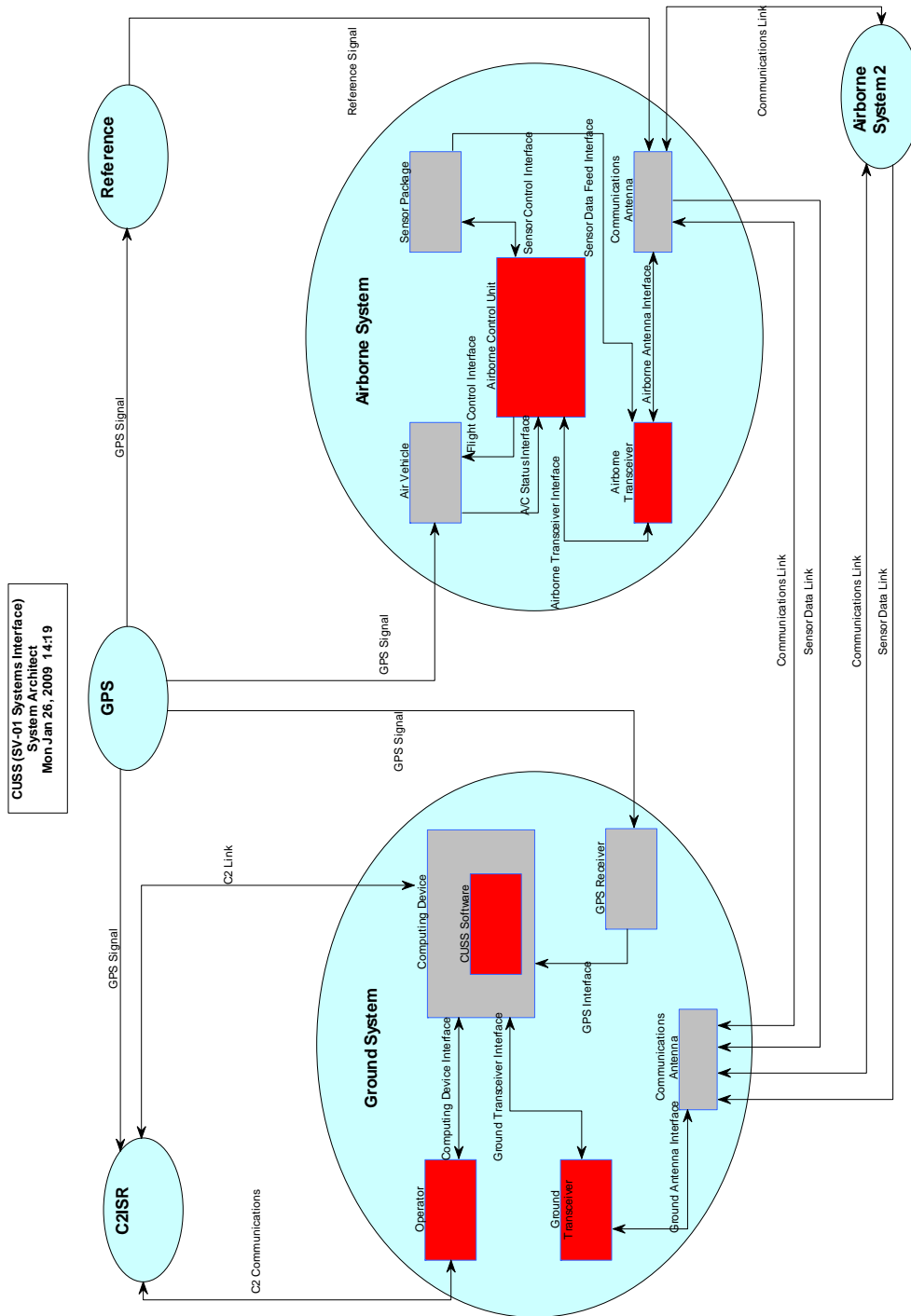

Figure 64. CUSS SV-1 System Interface Description



# Appendix I: CUSS SV-4 System Functionality Description

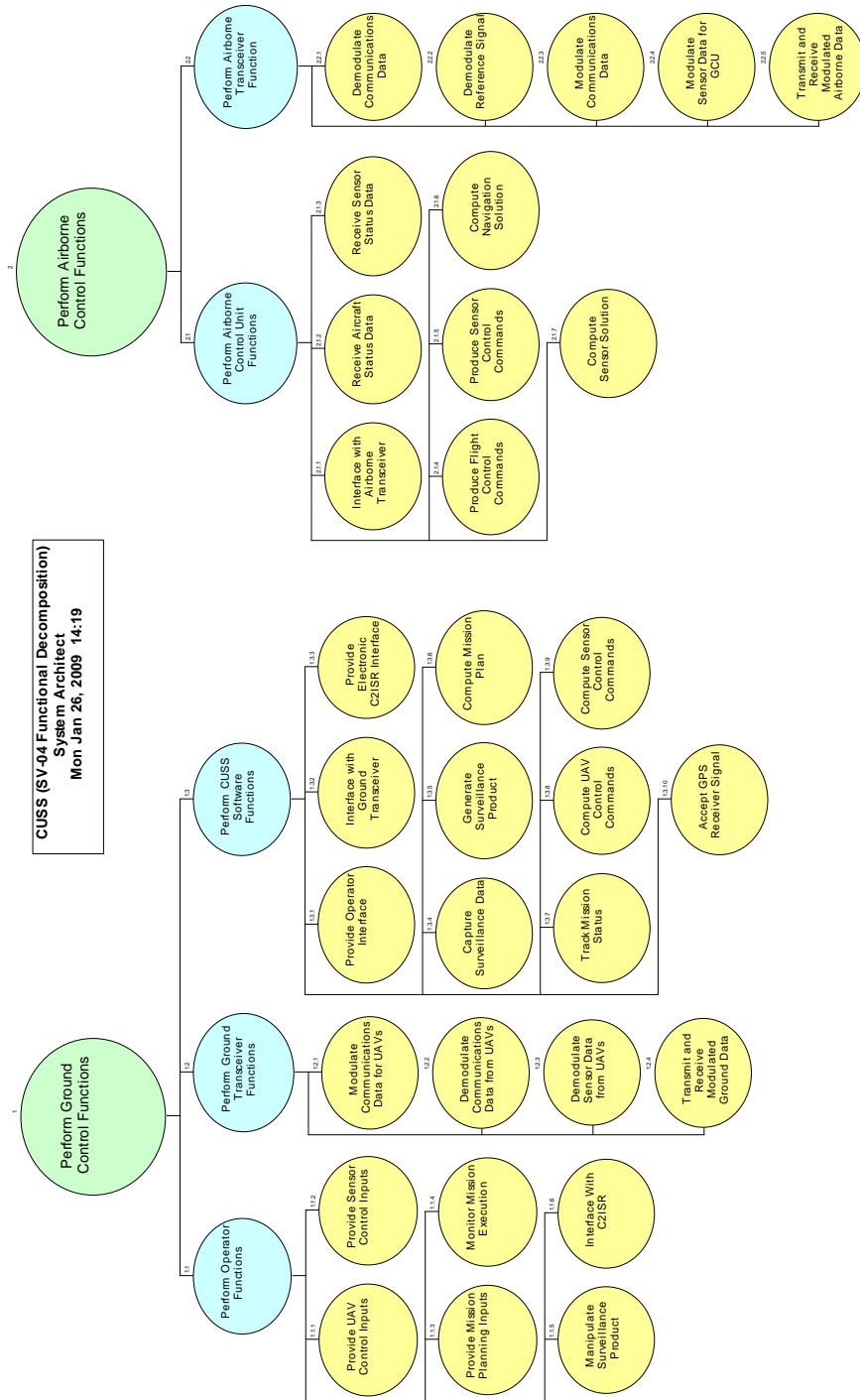

Figure 65. CUSS OV-4 System Functionality Description

# Appendix J: CUSS SV-5 Activity to Function Traceability Matrix

## Table 8. CUSS SV-5 Activity to Function Traceability Matrix

**SV-5**

SYSTEM FUNCTION		OPERATIONAL ACTIVITY	A1.1. Select Resources	A1.2. Set Constraints	A1.3. Set Mission Parameters	A1.4. Generate Mission Plan	A2.1. Conduct Mission	A2.2. Track Reference Point	A2.3. Manage Formation	A2.4. Navigate UAVs	A2.5. Generate Control Commands	A3.1. Manage Sensors	A3.2. Track Point Of Interest	A3.3. Generate Sensor Commands	M1. Process Data	M2. Record and Playback Data	M3. Interpret Data	M4. Produce Surveillance Product		
1. Perform Ground Control Functions	1.1. Perform Operator Functions	1.1.1. Provide UAV Control Inputs						X	X	X	X							X		
		1.1.2. Provide Sensor Control Inputs											X	X	X			X		
		1.1.3. Provide Mission Planning Inputs	X	X	X														X	
		1.1.4. Monitor Mission Execution					X												X	
		1.1.5. Manipulate Surveillance Product															X		X	
		1.1.6. Interface with C2ISR	X	X	X		X												X	
	1.2. Perform Ground Transceiver Functions	1.2.1. Modulate Communications Data for UAVs	1.2.1.1. Modulate Communications Data for UAVs						X	X	X	X		X	X					
			1.2.1.2. Demodulate Communications Data from UAVs					X	X	X			X	X		X				
			1.2.1.3. Demodulate Sensor Data from UAVs											X			X			
			1.2.1.4. Transmit and Receive Modulated Ground Data					X	X	X	X	X	X	X	X	X	X			
		1.3. Perform CUSS Software Functions	1.3.1. Provide Operator Interface	X	X	X	X	X	X	X	X	X	X	X	X	X	X	X	X	X
			1.3.2. Interface with Ground Transceiver					X	X	X	X	X	X	X	X	X	X			
			1.3.3. Provide Electronic C2ISR Interface	X	X	X		X												X
			1.3.4. Capture Surveillance Data														X	X		
			1.3.5. Generate Surveillance Product																	X
1.3.6. Compute Mission Plan						X														
2. Perform Airborne Control Functions	2.1. Perform Airborne Control Unit Functions	1.3.7. Track Mission Status	X			X	X	X	X				X							
		1.3.8. Compute UAV Control Commands							X	X	X									
		1.3.9. Compute Sensor Control Command											X	X	X					
		1.3.10. Accept GPS Receiver Signal			X			X												
		2.1.1. Interface with Airborne Transceiver					X	X	X	X	X	X	X	X	X	X				
		2.1.2. Receive Aircraft Status Data					X		X	X	X			X		X				
		2.1.3. Receive Sensor Status Data											X		X	X				
		2.1.4. Produce Flight Control Commands										X								
		2.1.5. Produce Sensor Control Commands														X				
		2.1.6. Compute Navigation Solution									X									
2.2. Perform Airborne Transceiver Function	2.2.1. Demodulate Communications Data	2.1.7. Compute Sensor Solution											X							
		2.2.1.1. Demodulate Communications Data						X	X	X	X		X	X						
		2.2.2. Demodulate Reference Signal						X												
		2.2.3. Modulate Communications Data					X	X	X			X	X		X					
		2.2.4. Modulate Sensor Data for GCU												X		X				
		2.2.5. Transmit and Receive Modulated Airborne Data					X	X	X	X	X	X	X	X	X	X				

## Appendix K: Test OV-1 System Concept

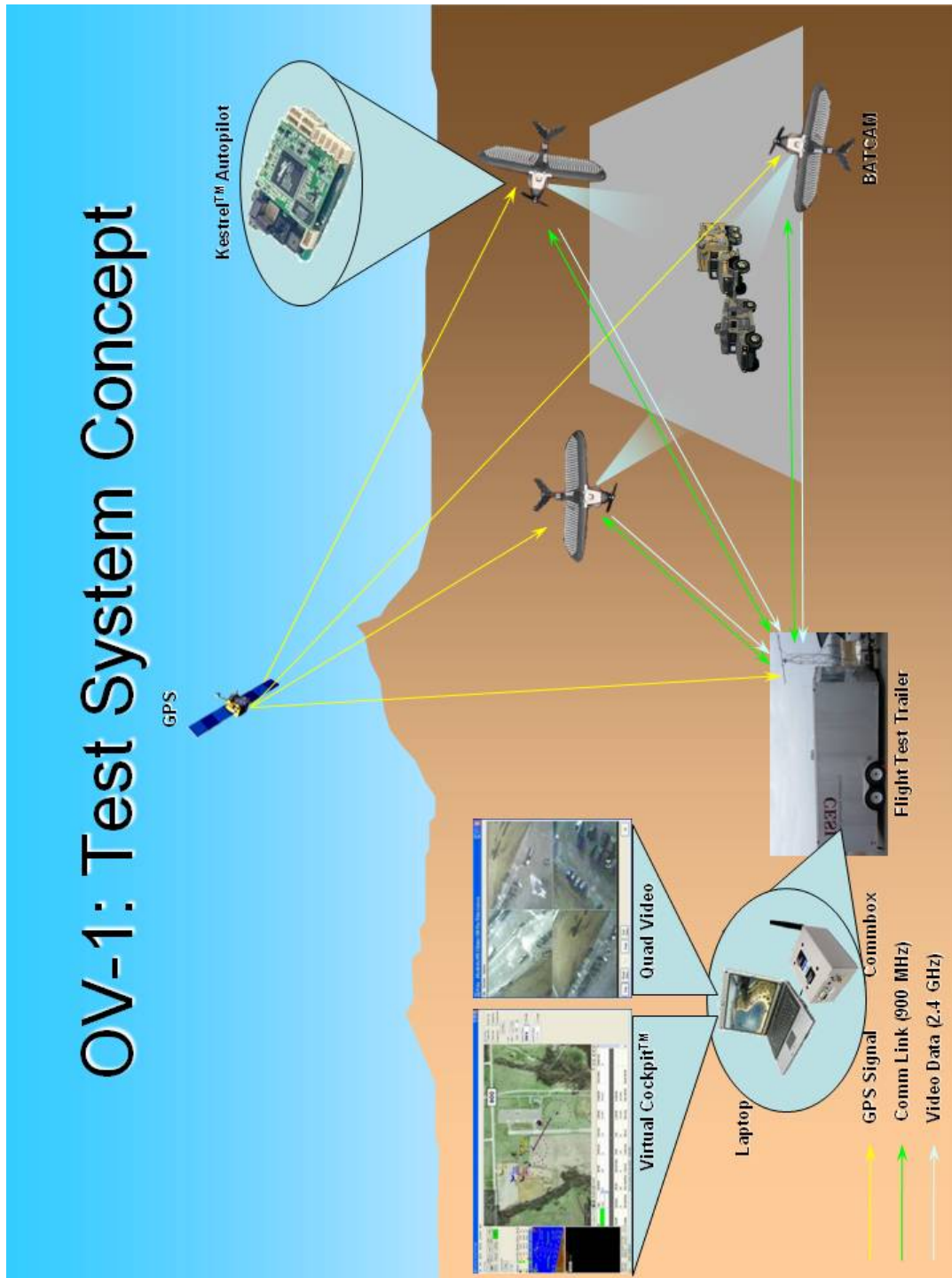

Figure 66. Test OV-1 System Concept

# Appendix L: Test OV-2 Operational Node Connectivity Description

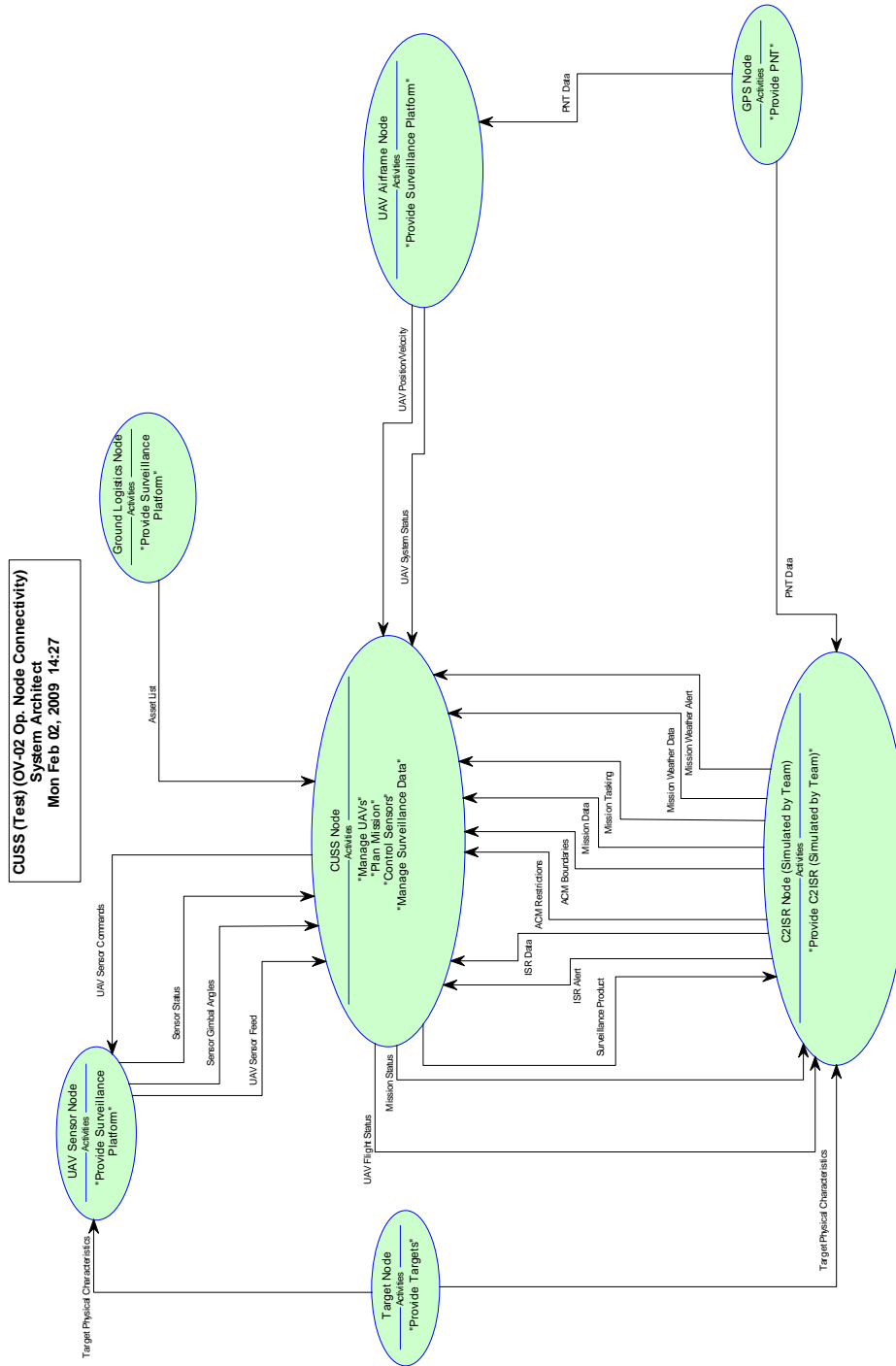

Figure 67. Test OV-2 Operational Node Connectivity Description

# Appendix M: Test OV-5 Operational Activity Model

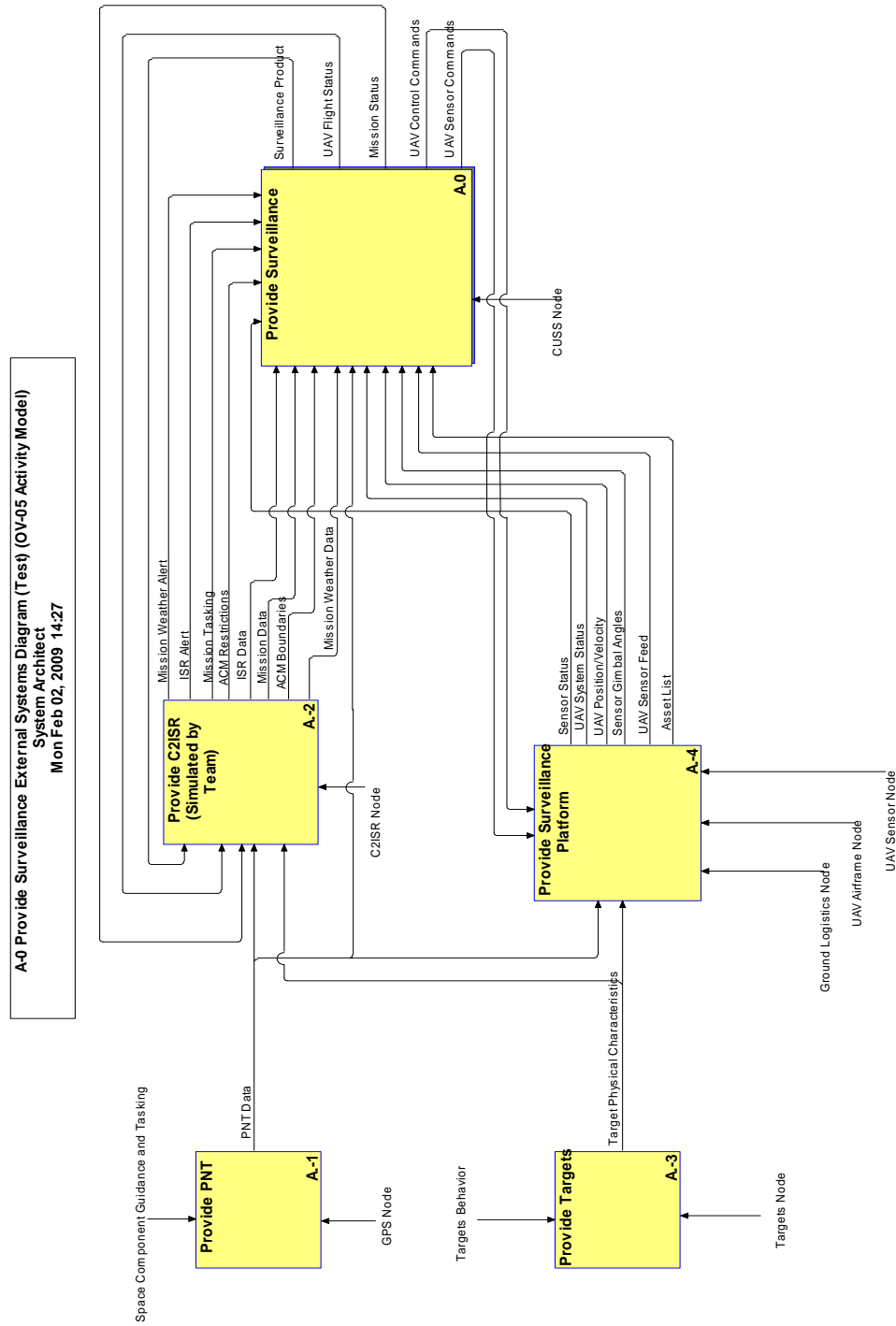
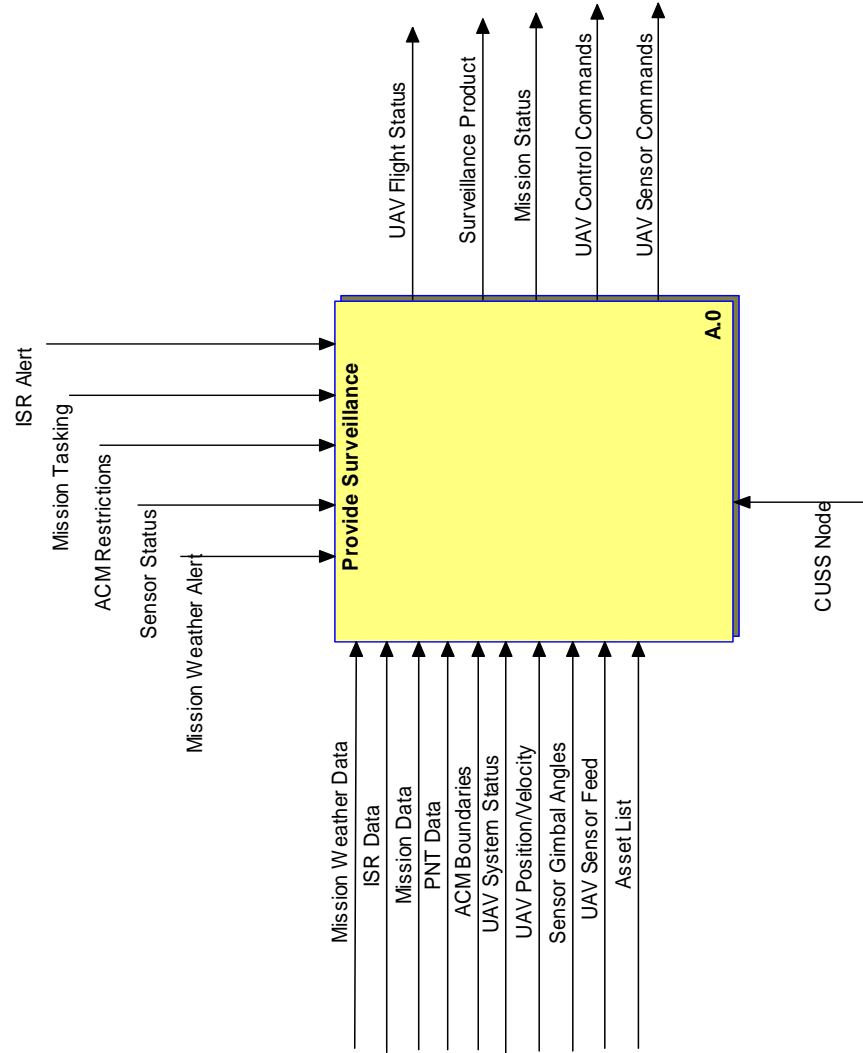
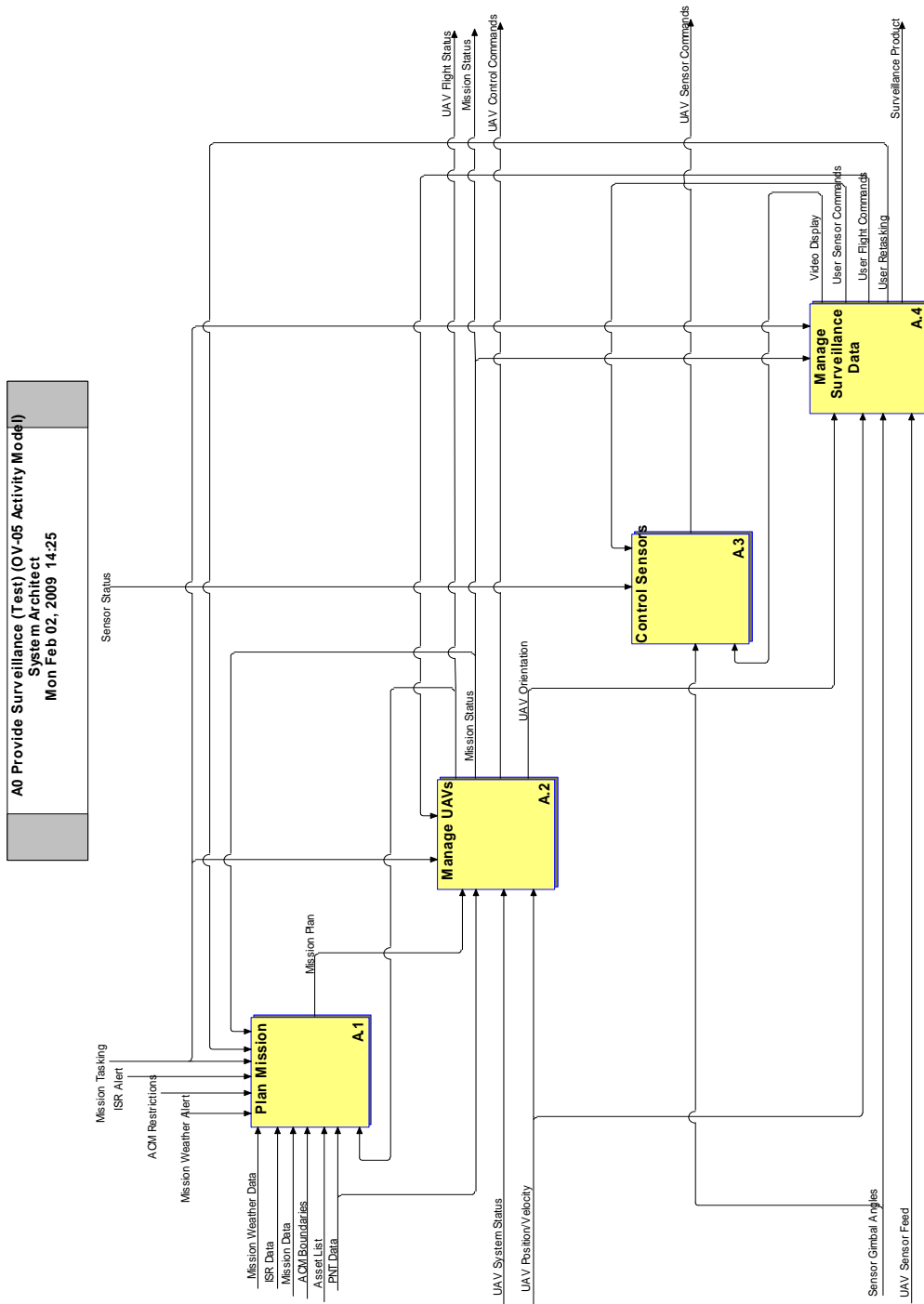

Figure 68. Test OV-5 A-0 External Systems Diagram

**A0 Provide Surveillance Context Diagram (Test) (OV-05 Activity Model)**  
**System Architect**  
**Mon Feb 02, 2009 14:27**



**Figure 69. Test OV-5 A0 Context Diagram**



**Figure 70. Test OV-5 A0 Provide Surveillance**

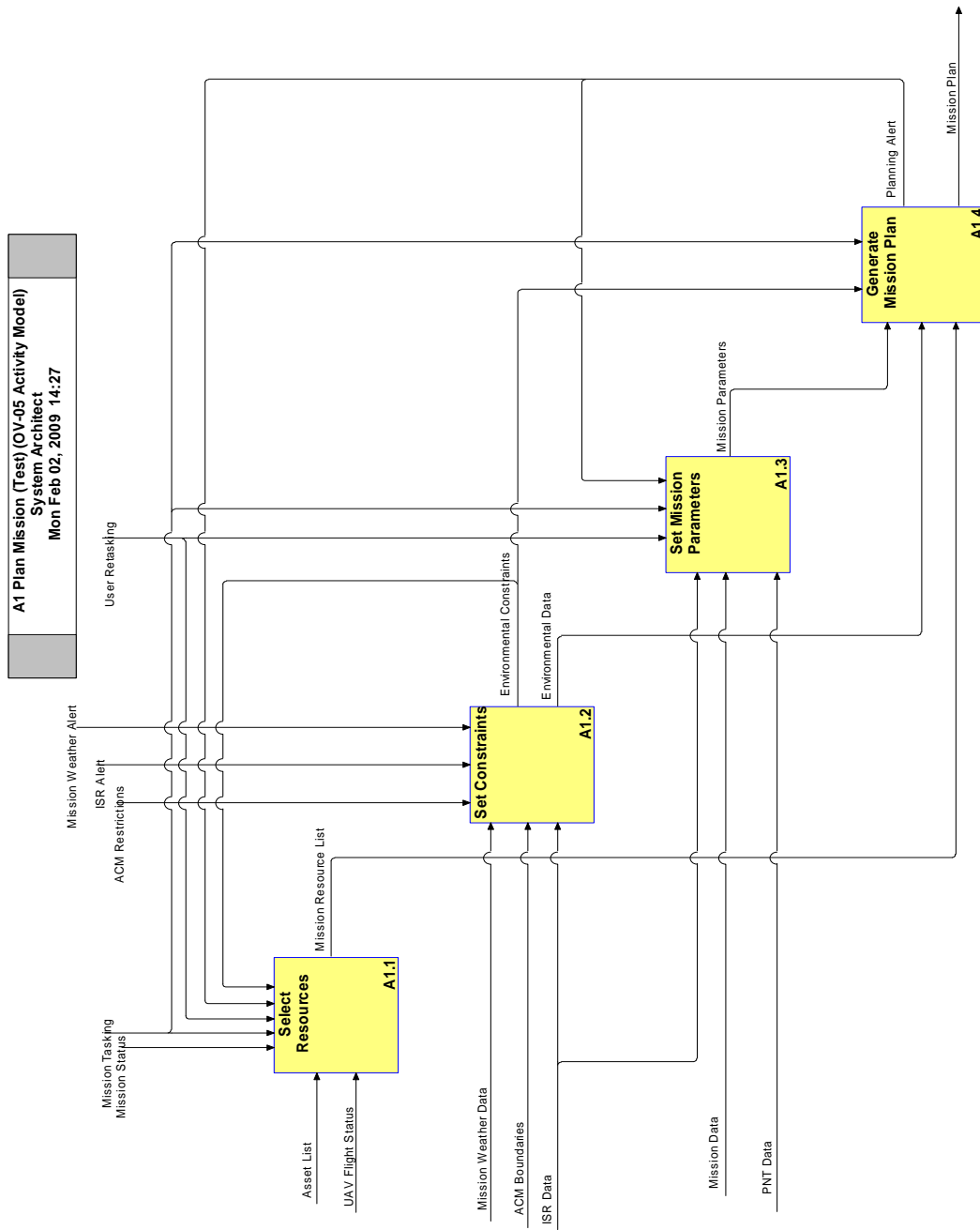

**Figure 71. Test OV-5 A1 Plan Mission**



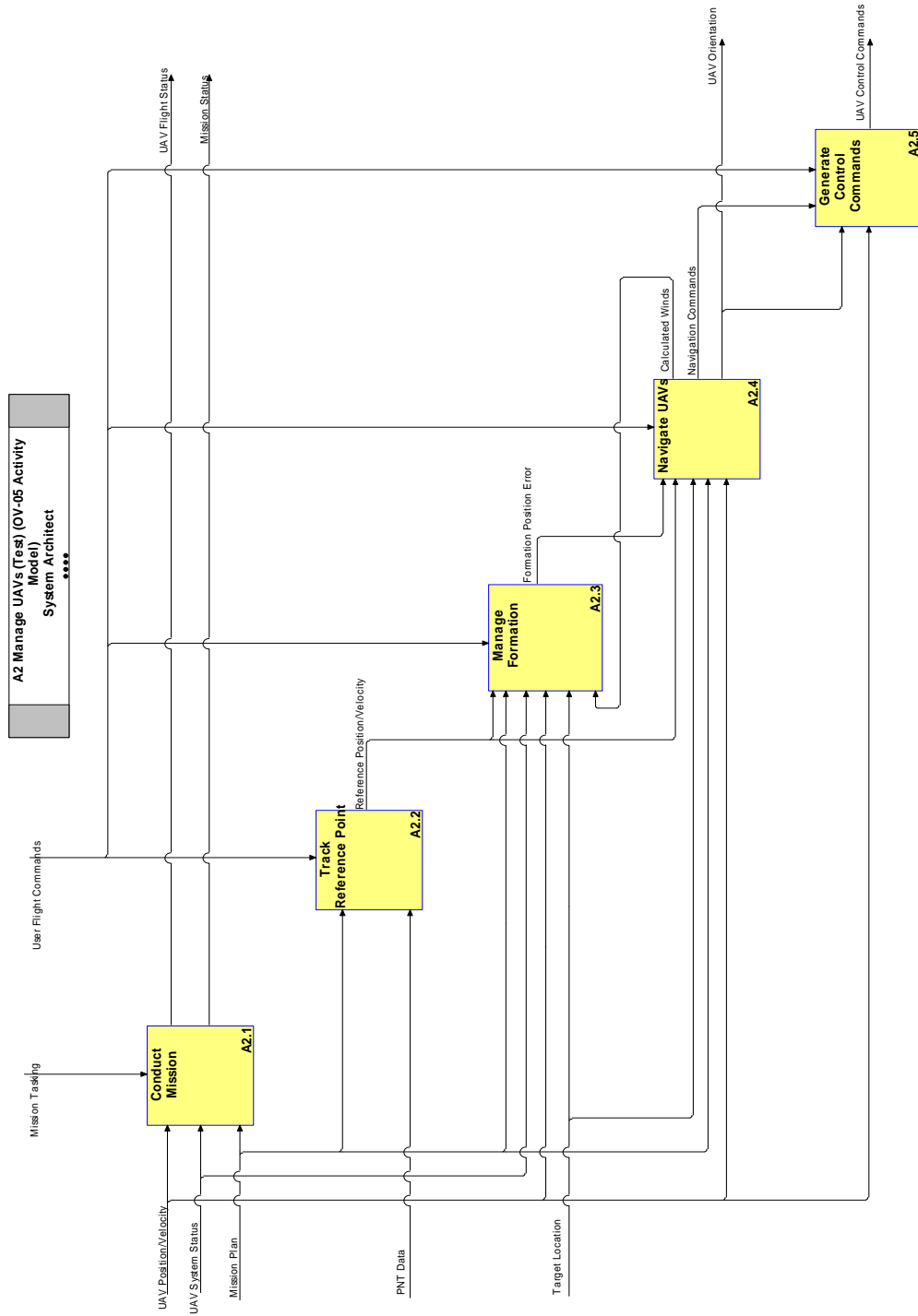

Figure 72. Test OV-5 A2 Manage UAVs

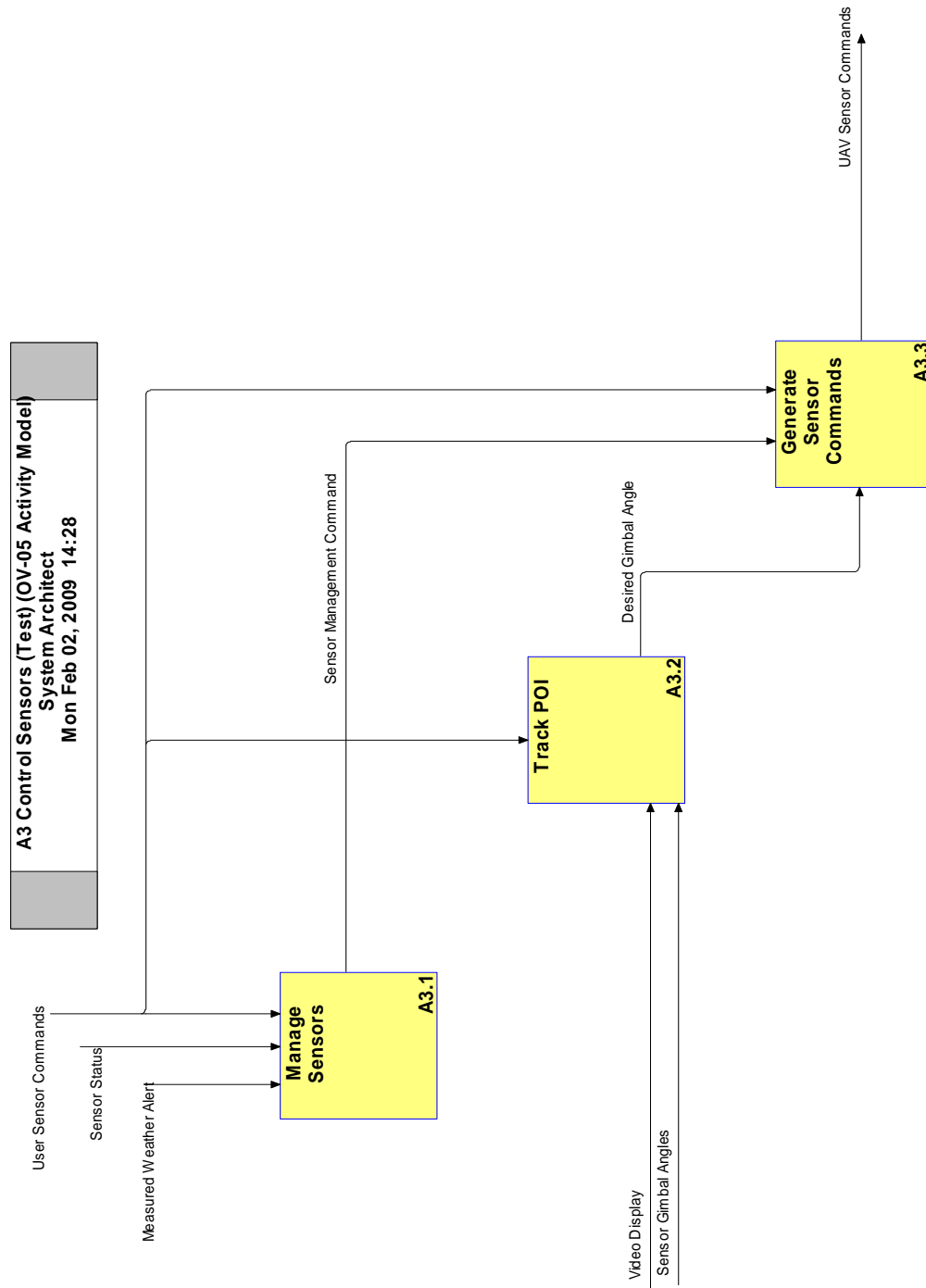

Figure 73. Test OV-5 A3 Control Sensors

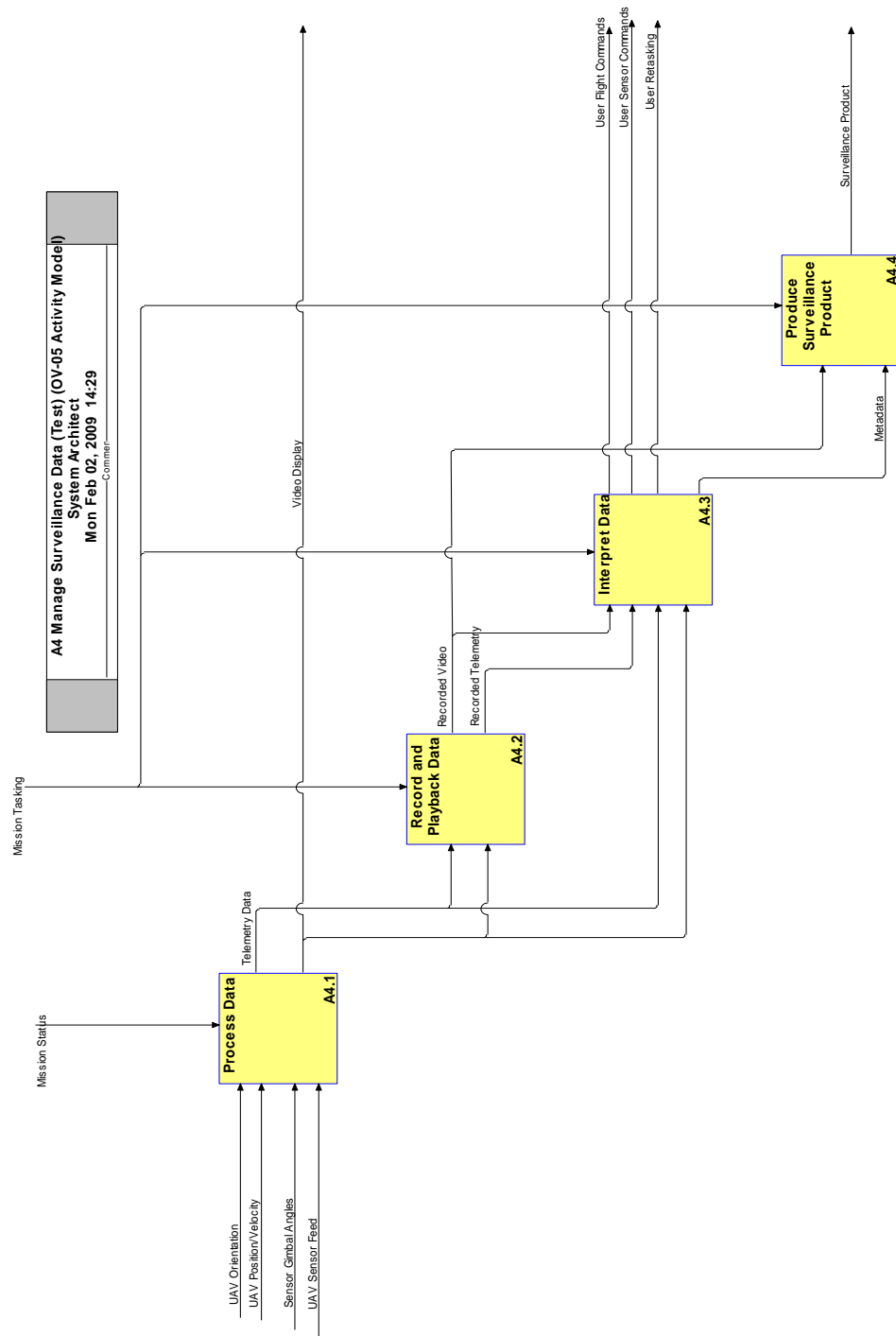

Figure 74. Test OV-5 A4 Manage Surveillance Data

## Appendix N: Test SV-1 System Interface Description

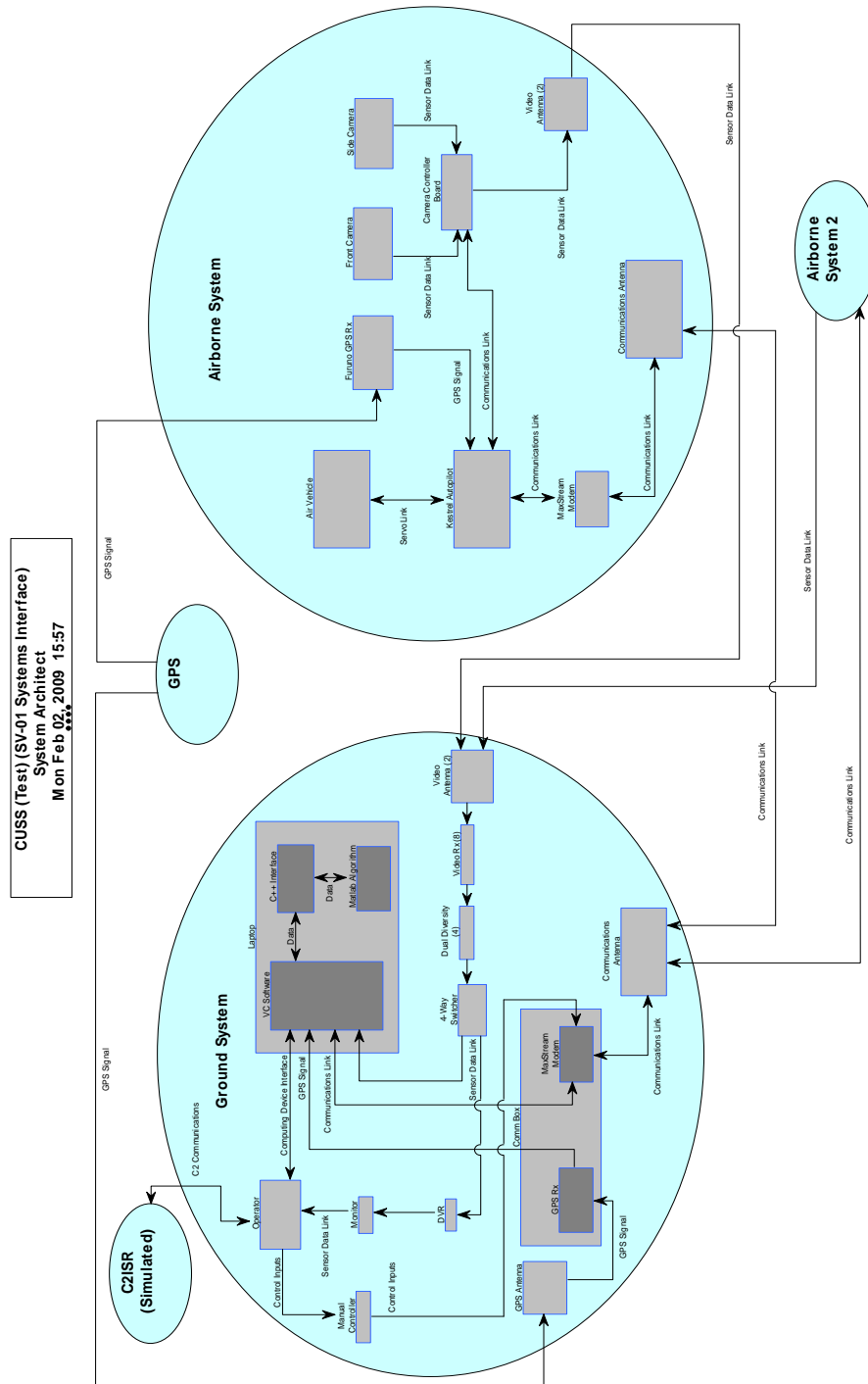

Figure 75. Test SV-1 System Interface Description

## Appendix O: Test to Conceptual Component Mapping Matrix

Table 9. Test to Conceptual Component Mapping Matrix

Test System to Conceptual System Component Mapping		Conceptual CUSS System Components										
		Ground System						Airborne System				
		Operator	Computing Device	CUSS Software	Ground Transceiver	GPS Receiver	Communications Antenna (Ground System)	Air Vehicle	Airborne Control Unit	Sensor Package	Airborne Transceiver	Communications Antenna (Airborne Node)
Test System Components	Operator	X										
	Laptop		X									
	Monitor		X									
	Manual R/C Controller		X									
	VC Software			X								
	C++ Interface			X								
	Matlab Algorithm			X								
	4-Way Switcher			X								
	DVR			X								
	Maxstream Modem in Commbx				X							
	Power Divider (2)				X							
	Video RX (8)				X							
	Oracle Dual Diversity (4)				X							
	AverMedia Video Capture Device				X							
	GPS Antenna					X						
	GPS Receiver					X						
	Video Antenna (2)						X					
	Communications Antenna (Ground System)						X					
	BATCAM Airframe							X				
	Furuno GPS RX							X				
Kestrel Autopilot								X				
Front Camera									X			
Side Camera									X			
Camera Controller Board									X			
Maxstream Modem (Airborne System)										X		
Communications Antenna (Airborne System)											X	
Video Antenna											X	

## Bibliography

1. Federal Emergency Management Agency. Remote Sensing in Federal Disaster Operations. Washington: June 1999.
2. Department of Defense. *Joint and National Intelligence Support to Military Operations*. JP 2-01. Washington: GPO, 7 October 2004.
3. Department of Defense. *Department of Defense Dictionary of Military and Associated Terms*. JP 1-02. Washington: GPO, 17 October 2008.
4. Department of the Air Force. *Intelligence, Surveillance, and Reconnaissance Operations*. AFDD 2-9. Maxwell AFB: HQ AFDC, 17 July 2007.
5. Garamone, Jim. "From the U.S. Civil War to Afghanistan: A Short History of UAVs." *Defend America*, 17 April 2002.  
<http://www.defendamerica.mil/articles/apr2002/a041702a.html>. 21 January 2009.
6. "RQ-4 Global Hawk Unmanned Aircraft System." *Air Force Link* Fact Sheet, October 2008. <http://www.af.mil/factsheets/factsheet.asp?fsID=13225>. 21 January 2009.
7. *UAV Forum*. [http://uavforum.org/gallery/Firebee/Firebee\\_Launch.jpg](http://uavforum.org/gallery/Firebee/Firebee_Launch.jpg). 10 March 2009.
8. Clemons, Steve. "Is the U.S. Flying Fighter Aircraft and UAVs Over Iranian Airspace?" *The Washington Note*, 9 September 2006.  
<http://www.thewashingtonnote.com/archives/001635.php>. 10 March 2009.
9. "File: RQ-2B pioneer uav.jpg." *Wikimedia Commons*.  
[http://commons.wikimedia.org/wiki/File:RQ-2B\\_pioneer\\_uav.jpg](http://commons.wikimedia.org/wiki/File:RQ-2B_pioneer_uav.jpg). 10 March 2009.
10. *Wired.com* Photos.  
<http://blog.wired.com/photos/uncategorized/2007/03/29/predator.jpg>. 10 March 2009.
11. "RQ-4A/B Global Hawk High-Altitude, Long-Endurance, Unmanned Reconnaissance Aircraft, USA." *Airforce-Technology.com*. <http://www.airforce-technology.com/projects/global/global4.html>. 10 March 2009.
12. Office of the Secretary of Defense. *Unmanned Systems Roadmap (2007-2032)*. Washington: 10 December 2007.

13. United States Government Accountability Office. *Unmanned Aircraft Systems: Advance Coordination and Increased Visibility Needed to Optimize Capabilities*. GAO-07-836. Washington: 11 July 2007.
14. Deptula, David A. "Unmanned Aircraft Systems: Taking Strategy to Task." *Joint Force Quarterly*, Issue 49: 49-51 (2nd Quarter 2008).
15. Kappenman, Jeffrey. "Army Unmanned Aircraft Systems: Decisive in Battle." *Joint Force Quarterly*, Issue 49: 20-23 (2nd Quarter 2008).
16. Office of the Secretary of Defense. *Quadrennial Defense Review Report*. Washington: 6 February 2006.
17. Air Land Sea Application Center. *Multi-Service Tactics, Techniques, and Procedures for the Tactical Employment of Unmanned Aircraft Systems*. FM 3-04.15, NTTP 3-55.14, AFTTP(I) 3-2.64. Langley AFB: ALSA, August 2006.
18. Air Land Sea Application Center. *Multi-Service Tactics, Techniques, and Procedures for Tactical Convoy Operations*. FM 4-01.45, MCRP 4-11.3H, NTTP 4-01.3, AFTTP(I) 3-2.58. Langley AFB: ALSA, March 2005.
19. Wise, Jeff. "Civilian UAVs: No Pilot, No Problem." *Popular Mechanics*, April 2007. [http://www.popularmechanics.com/science/air\\_space/4213464.html](http://www.popularmechanics.com/science/air_space/4213464.html). 22 January 2009.
20. Alighanbari, Mehdi, Yoshiaki Kuwata, and Jonathan P. How. "Coordination and Control of Multiple UAVs with Timing Constraints and Loitering," in *Proceedings of the American Control Conference*. IEEE, June 2003.
21. Bellingham, John, Michael Tillerson, Arthur Richards, and Jonathan P. How. "Multi-Task Allocation and Path Planning for Cooperating UAVs," in *Conference on Coordination, Control and Optimization*. November 2001.
22. Richards, Arthur, and Jonathan P. How. "Aircraft Trajectory Planning With Collision Avoidance Using Mixed Integer Linear Programming," in *Proceedings of the American Control Conference*. IEEE, May 2002.
23. Mathia, Karl, Gerardo Lafferriere, and Todd Tiltensor. "Cooperative Control of UAV Platoons – A Prototype," in *Proceedings of the Euro UAV 2007 Conference and Exhibition*. June 2007.
24. Cole, David T., Ali Haydar Gökdoğan, and Salah Sukkarieh. "The Demonstration of a Cooperative Control Architecture for UAV Teams," in *Experimental Robotics: The 10<sup>th</sup> International Symposium on Experimental Robotics*. Berlin / Heidelberg: Springer-Verlag, January 2008.

25. How, Jonathan, Ellis King, and Yoshiaki Kuwata. "Flight Demonstrations of Cooperative Control for UAV Teams," in *AIAA 3<sup>rd</sup> "Unmanned Unlimited" Technical Conference, Workshop and Exhibit*. AIAA, September 2004.
26. Kingston, Derek, Randal Beard, and Ryan Holt. *Decentralized Perimeter Surveillance Using a Team of UAVs*. IEEE Transactions on Robotics Paper. 2 October 2007.
27. Cooper, Cory A., Matthew L. Ewoldt, Steaven A. Meyer, and Edward W. Talley. *A Systems Architectural Model for Man-Packable/Operable Intelligence, Surveillance, and Reconnaissance Mini/Micro Aerial Vehicles*. MS thesis, AFIT/ENY/GSE/05-M02. School of Graduate School of Engineering & Management, Air Force Institute of Technology (AU), Wright-Patterson AFB, OH, March 2005.
28. Laird, Maj Abbot, Christian Stillings, Maj Craig Phillips, and Capt Garrett Knowlan. *Systems Engineering Analysis for Transition of the Fleeting Target Technology Demonstrator*. MS thesis, AFIT/GSE/ENY/07-M03. School of Graduate School of Engineering & Management, Air Force Institute of Technology (AU), Wright-Patterson AFB, OH, March 2007.
29. Sakyrd, LCDR Gregory A., and Capt Douglas A. Ericson. *Systems Engineering Analysis for the Development of the Fleeting Target Technology Demonstrator*. MS thesis, AFIT/GSE/ENV/08-M06. School of Graduate School of Engineering & Management, Air Force Institute of Technology (AU), Wright-Patterson AFB, OH, March 2008.
30. Terning, Capt Nate A. *Real-Time Flight Path Optimization for Tracking Stop-and-Go Targets with Micro Air Vehicles*. MS thesis, AFIT/GAE/ENY/08-M28. School of Graduate School of Engineering & Management, Air Force Institute of Technology (AU), Wright-Patterson AFB, OH, March 2008.
31. Vantrease, ENS Troy H. *Development and Employment of a Semi-Autonomous Cursor on Target Navigation System for Micro Air Vehicles*. MS thesis, AFIT/GAE/ENY/08-J06. School of Graduate School of Engineering & Management, Air Force Institute of Technology (AU), Wright-Patterson AFB, OH, June 2008.
32. Hansen, 2Lt John H. *Optimal Guidance of a Relay MAV for ISR Support Beyond Line-of-Sight*. MS thesis, AFIT/GAE/ENY/08-M15. School of Graduate School of Engineering & Management, Air Force Institute of Technology (AU), Wright-Patterson AFB, OH, March 2008.
33. Farrell, Capt Shannon M. *Waypoint Generation Based on Sensor Aimpoint*. MS thesis, AFIT/GAE/ENV/09-M01. School of Graduate School of Engineering & Management, Air Force Institute of Technology (AU), Wright-Patterson AFB, OH, March 2009.



34. Booth, Capt Christopher E. *Surveillance Using Multiple Unmanned Aerial Vehicles*. MS thesis, AFIT/GSS/ENY/09-M02. School of Graduate School of Engineering & Management, Air Force Institute of Technology (AU), Wright-Patterson AFB, OH, March 2009.
35. Rosal, Capt Joseph D. *Centralized Cooperative Control for Route Surveillance with Constant Communication*. MS thesis, AFIT/GE/ENG/09-38. School of Graduate School of Engineering & Management, Air Force Institute of Technology (AU), Wright-Patterson AFB, OH, March 2009.
36. Smith, Austin L. *UAS Collision Avoidance Algorithm that Minimizes the Impact on Route Surveillance*. MS thesis, AFIT/GAE/ENY/09-M18. School of Graduate School of Engineering & Management, Air Force Institute of Technology (AU), Wright-Patterson AFB, OH, March 2009.
37. Lenfestey, Maj Adam, and Capt Eric Cring. *Architecting Human Operator Trust in Automation to Improve System Effectiveness in Multiple Unmanned Aerial Vehicle (UAV) Control*. MS thesis, AFIT/GSE/ENV/09-M06. School of Graduate School of Engineering & Management, Air Force Institute of Technology (AU), Wright-Patterson AFB, OH, March 2009.
38. Department of Defense. *Systems Engineering Fundamentals*. Washington: GPO, January 2001.
39. Department of Defense. *Joint Capabilities Integration and Development System (JCIDS)*. CJCS 3170.01F. Washington: GPO, 1 May 2007.
40. Department of Defense. *Defense Acquisition Guide Book*. DoDD 5000.1 & DoDI 5000.2. Washington: GPO, November 20, 2007.
41. Department of Defense. *DoD Architecture Framework Version 1.5, Volume I: Definitions and Guidelines*. Washington, GPO, 23 April 2007.
42. Department of Defense. *Air Force Policy Directive 10-28, Air Force Concept Development*. Washington: GPO, 15 December 2003.
43. Buede, Dennis. *The Engineering Design of Systems*. New York: John Wiley & Sons 2000.
44. Hartt, Maj Brian. Briefing, DoD Architecture Framework Executive Seminar. Air Force Institute of Technology (AU), Wright-Patterson AFB, OH.
45. Department of Defense. *DoD Architecture Framework Version 1.5, Volume II: Product Descriptions*. Washington: GPO, 23 April 2007.

46. *Telelogic System Architect*. <http://www-01.ibm.com/software/awdtools/systemarchitect/>. 19 February 2009.
47. *Kestrel User Guide: Kestrel Autopilot (Firmware Version MA8.2) & Virtual Cockpit 2.4.3*. Procerus Technologies Manual. 22 April 2008.
48. “VIRTUAL cockpit™.” *Procerus Technologies*. <http://www.procerusuav.com/productsGroundControl.php>. 10 March 2009.
49. *Aviones: UAV Flight Simulator*. 3 April 2007. <http://aviones.sourceforge.net/>. 19 February 2009.

REPORT DOCUMENTATION PAGE			Form Approved OMB No. 074-0188		
<p>The public reporting burden for this collection of information is estimated to average 1 hour per response, including the time for reviewing instructions, searching existing data sources, gathering and maintaining the data needed, and completing and reviewing the collection of information. Send comments regarding this burden estimate or any other aspect of the collection of information, including suggestions for reducing this burden to Department of Defense, Washington Headquarters Services, Directorate for Information Operations and Reports (0704-0188), 1215 Jefferson Davis Highway, Suite 1204, Arlington, VA 22202-4302. Respondents should be aware that notwithstanding any other provision of law, no person shall be subject to a penalty for failing to comply with a collection of information if it does not display a currently valid OMB control number.</p> <p><b>PLEASE DO NOT RETURN YOUR FORM TO THE ABOVE ADDRESS.</b></p>					
<b>1. REPORT DATE (DD-MM-YYYY)</b> 13-03-2009		<b>2. REPORT TYPE</b> Graduate Research Paper		<b>3. DATES COVERED (From – To)</b> May 2008 – Feb 2009	
<b>4. TITLE AND SUBTITLE</b>  Cooperative Unmanned Aerial Surveillance Control System Architecture			<b>5a. CONTRACT NUMBER</b>		
			<b>5b. GRANT NUMBER</b>		
			<b>5c. PROGRAM ELEMENT NUMBER</b>		
<b>6. AUTHOR(S)</b>  Diamond, Theodore T., LCDR, USN Rutherford, Adam L., Maj, USAF Taylor, Jonathan B., Maj, USAF			<b>5d. PROJECT NUMBER</b> JON 09ENY147		
			<b>5e. TASK NUMBER</b>		
			<b>5f. WORK UNIT NUMBER</b>		
<b>7. PERFORMING ORGANIZATION NAME(S) AND ADDRESS(S)</b>  Air Force Institute of Technology Graduate School of Engineering and Management (AFIT/EN) 2950 Hobson Way WPAFB OH 45433-7765			<b>8. PERFORMING ORGANIZATION REPORT NUMBER</b>  AFIT/GSE/ENV/09-M07		
<b>9. SPONSORING/MONITORING AGENCY NAME(S) AND ADDRESS(ES)</b>  AFRL/RV, Dr. Alok Das, 2241 Avionics Circle, WPAFB OH 45433, (937) 904-9882 AFRL/RB, Dr. Mark Mears, 2130 Eighth St, WPAFB, OH 45433, (937) 255-8685			<b>10. SPONSOR/MONITOR'S ACRONYM(S)</b>  AFRL/RB, AFRL/RV		
			<b>11. SPONSOR/MONITOR'S REPORT NUMBER(S)</b>		
<b>12. DISTRIBUTION/AVAILABILITY STATEMENT</b>  APPROVED FOR PUBLIC RELEASE; DISTRIBUTION UNLIMITED					
<b>13. SUPPLEMENTARY NOTES</b>  This material is declared a work of the U.S. Government and is not subject to copyright protection in the United States.					
<b>14. ABSTRACT</b>  Intelligence, surveillance and reconnaissance (ISR) is a high-demand Department of Defense mission performed by unmanned aircraft systems (UAS) at the tactical and theater levels. Coordinating UAS aircraft through cooperative control offers the advantages of persistence, distributed and adaptable sensor coverage, and reduced revisit time on points of interest. The purpose of this thesis is to apply systems engineering principals to the problem of developing a flexible, common control system for cooperative UAS surveillance at the tactical level. The AFIT team developed a concept of operations (CONOPS) encompassing various users and surveillance tasks. The team then used the scenarios in the CONOPS to build a conceptual architecture. Simultaneously, the team constructed and flew a developmental test system that closely resembled the architecture. The team then used this architecture and the prototype system to identify significant technical risks and future research areas to be explored prior to the development of an operational system.					
<b>15. SUBJECT TERMS</b>  UAV, UAS, Cooperative Control, Systems Engineering					
<b>16. SECURITY CLASSIFICATION OF:</b>		<b>17. LIMITATION OF ABSTRACT</b>  UU	<b>18. NUMBER OF PAGES</b>  218	<b>19a. NAME OF RESPONSIBLE PERSON</b> Dr. David R. Jacques, PhD (ENV)	
a. REPORT U	b. ABSTRACT U			<b>19b. TELEPHONE NUMBER (Include area code)</b> (937) 255-3355 x3329	
			Standard Form 298 (Rev. 8-98) Prescribed by ANSI Std. Z39-18		
			Form Approved OMB No. 074-0188		